

TECHNICAL MANUAL

**OPERATOR'S AND UNIT MAINTENANCE
MANUAL
(INCLUDING REPAIR PARTS AND SPECIAL TOOLS LIST)
FOR
HEATER, SPACE, RADIANT, LARGE (H-45)
(TYPE I, SOLID FUEL)
NSN 4520-01-354-1191
(TYPE II, LIQUID FUEL)
NSN 4520-01-329-3451**

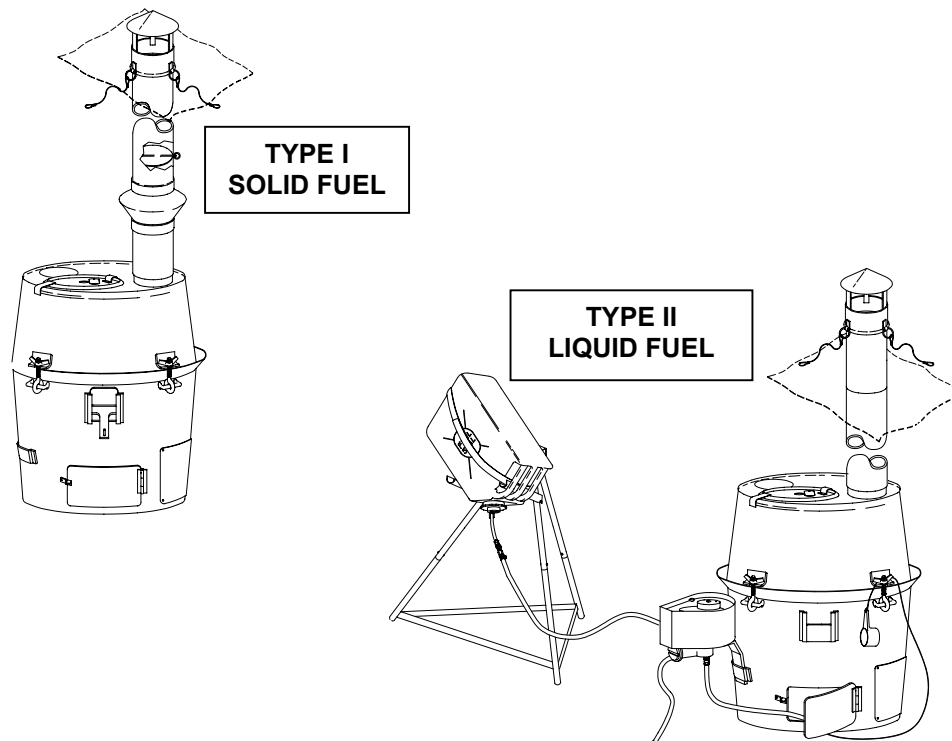

DISTRIBUTION STATEMENT A – Approved for public release; distribution is unlimited.

*This manual supersedes Army TM 9-4520-257-12&P, dated 17 September 1992.

**HEADQUARTERS, DEPARTMENT OF THE ARMY
30 SEPTEMBER 2003**

PCN 184 095440 00

THIS PAGE INTENTIONALLY LEFT BLANK

This warning summary contains general safety warnings and hazardous material warnings that must be understood and applied during operations and maintenance of this equipment. Failure to observe these precautions could result in serious injury or death to personnel.

WARNING



Interchanging fuel flow control valves between H-45 Large Radiant Space Heater and Space Heater, Arctic (SHA) is not allowed. Operating a heater with an incorrect valve could result in fire or explosion.

Do not use unauthorized fuels. Use of unauthorized fuels may result in fire or explosion.

Do not operate the H-45 without a functional fire extinguisher available. Failure to have a fire extinguisher available could result in injury or death to personnel should a fire breakout.

Tent exhaust opening closure flap must be rolled and tied securely. (Refer to tent-specific operator manual for procedure.) The tent may catch fire if hot stack assembly contacts the flap.

Ensure pipe stack sections seat together fully. Poorly fitted pipe stack sections may allow hot stack to fall on tent and start a fire or allow deadly carbon monoxide to leak into the tent.

Set up fuel supply on a clear site at least 7 feet (2.13 meters, or 2.13 m) from tent and away from flame sources. Heat or sparks from stack assembly could ignite fuel supply resulting in fire or explosion.

Properly install fuel flow control valve assembly. If fuel flow control valve assembly is improperly positioned or if bracket is bent, a fuel overflow could occur inside burner shell and cause fire or explosion.

Allow at least 4 feet (1.22 m) of space between the heater and the tent wall. Placing the heater too close to the tent wall may result in fire.

Never relight an extinguished flame while the heater is hot. Be sure to allow the heater to cool completely before attempting to relight or an explosion may result.

Do not attempt to replenish the fuel supply while the heater is in operation. Doing so may cause fire or explosion.

Be certain that there is no open flame in the vicinity of liquid fuel. Failure to do so could result in fire or explosion.

WARNING



Used motor oil, solvents, and other unauthorized fuels should **NOT** be used with the H-45 under any circumstance. **Only approved liquid and solid fuels may be used. Gasoline and JP-4 should be used only in emergency situations when there is no other fuel available and when the soldier's health and unit readiness are in jeopardy.** Using gasoline, JP-4, or unauthorized fuels in the H-45 will create a fire danger and potential for explosion.

All equipment must be free from fuel residue before packaging. Failure to observe this warning may result in fire or explosion during or after the packing of the components.

WARNING



When operating the heater in solid fuel mode, a buildup of creosote can accumulate on the inside surface of the stack assembly. To prevent creosote buildup when operating with solid fuel, the stack assembly should be cleaned daily. Failure to do so may result in fire causing severe injury or death.

WARNING



The metal surfaces of the H-45 heater body are protected with a preservative film when shipped from the manufacturer that must be burned off prior to first time use of the heater in an enclosed area. To burn off the protective film, set up the H-45 in an open outside area and light in accordance with WP0005. Once the heater is hot, smoke will be seen coming off the metal surfaces as the preservative burns off. Allow the heater to burn until no more smoke is observed. Shut the heater down, allow it to cool, and prepare it for movement as detailed in WP0005.

During operation, the H-45 produces harmful carbon monoxide (CO) and other gases. Carbon monoxide is a colorless, odorless, and tasteless gas. Remember that although CO has no telltale odor, it may mix with other odors that mask its presence; therefore, CO can be present within a mix of seemingly harmless odors. Mild cases of carbon monoxide poisoning can cause symptoms such as nausea, dizziness, or headaches. Severe cases of carbon monoxide poisoning can result in brain damage, heart damage, or death.

To prevent CO poisoning, ensure that the H-45 exhaust stack sections fit together snugly and that the exhaust gases are properly vented through the roof of the shelter. Failure to do so could result in injury or death.

The best way to prevent CO poisoning is to keep the H-45 in good working order. Ensure that all possible sources of CO leakage have been repaired and that the operating space is well ventilated. Failure to do so could result in injury or death.

WARNING



Do not attempt to handle or perform services on an H-45 that has recently been in operation. Let the space heater cool down before performing these procedures. Failure to do so could result in serious burns.

WARNING



The H-45 weighs approximately 72 pounds (32.66 kg) for the Type I (Solid Fuel) and approximately 75 pounds (34.02 kg) for the Type II (Liquid Fuel). Two persons must carry the H-45, lifting with legs, not back, to prevent injury.

WARNING



Some metal components of H-45 may have sharp edges. Wear protective gloves and be careful when handling and assembling the H-45 stack pipe. Failure to do so could result in serious cuts.

WARNING



Protective gloves should be worn when handling metal parts in below freezing temperatures. Failure to wear gloves may result in skin freezing to the metal upon contact and cause tearing of the flesh when attempting to pull away from the metal.

Do not allow liquid fuel to come in contact with bare skin. Wear protective gloves whenever handling or working with liquid fuel. Even though fuel does not freeze, it is extremely cold and will burn exposed skin on contact.

WARNING



Clean fuel, used to clean parts, is potentially dangerous to personnel and property. Avoid repeated and prolonged skin contact. Do not use near an open flame or excessive heat. Failure to do so may result in damage to skin and/or fire or explosion.

THIS PAGE INTENTIONALLY LEFT BLANK

INSERT LATEST UPDATED PAGES/WORK PACKAGES, DESTROY SUPERSEDED DATA

LIST OF EFFECTIVE PAGES

DATE OF ISSUE FOR ORIGINAL IS: 30 SEPTEMBER 2003

NOTE

The portion of text affected by the update is indicated by a vertical line in the outer margins of the page. Updates to illustrations are indicated by miniature pointing hands.

Total number of pages for front and rear matter is 18. The total number of work packages is 53, consisting of the following:

Page/Work Package No.	*Change No.	Page/Work Package No.	*Change No.
Front Cover	0		
a – d	0		
A – B	0		
i – iv	0		
WP 0001 00 – 0053 00	0		
Index 1 – Index 4	0		
Authentication Page	0		
2028 Instructions	0		
Sample DA From 2028	0		
Blank Form 2028	0		
Back Cover	0		

***Zero in this column indicates an original page or work package**

THIS PAGE INTENTIONALLY LEFT BLANK

HEADQUARTERS,
DEPARTMENTS OF THE ARMY & NAVY
WASHINGTON, D.C., 30 SEPTEMBER 2003

**OPERATOR'S AND UNIT MAINTENANCE MANUAL
(INCLUDING REPAIR PARTS AND SPECIAL TOOLS LIST)
FOR
HEATER, SPACE, RADIANT, LARGE (H-45)
TYPE I, SOLID FUEL
(NSN 4520-01-354-1191)
TYPE II, LIQUID FUEL
(NSN 4520-01-329-3451)**

You can help improve this manual. If you find any mistakes or if you know of a way to improve the procedures, please let us know. Mail your letter together with DA Form 2028 (Recommended Changes to Publications and Blank Forms), located in the back of this manual, directly to: Commander, U.S. Army Soldier and Biological Chemical Command, ATTN: AMSSB-RIM-L(N), Kansas Street, Natick, MA 01760-5052. You may also send in your recommended changes via electronic mail directly to amssbriml@natick.army.mil. A reply will be furnished to you. Instructions for sending an electronic 2028 may be found at the back of this manual immediately preceding the hard copy 2028.

DISTRIBUTION STATEMENT A – Approved for public release. Distribution is unlimited.

TABLE OF CONTENTS

	WP Sequence No.
WARNING SUMMARY	
HOW TO USE THIS MANUAL	
General Information.....	0001 00
<hr/>	
CHAPTER 1 – DESCRIPTION AND THEORY OF OPERATION	
Equipment Description And Data	0002 00
Theory Of Operation.....	0003 00
<hr/>	
CHAPTER 2 - OPERATOR INSTRUCTIONS	
Description And Use Of Operational Controls And Indicators.....	0004 00
Operation Under Usual Conditions.....	0005 00
Operation Under Unusual Conditions.....	0006 00
<hr/>	
CHAPTER 3 –TROUBLESHOOTING PROCEDURES	
Troubleshooting Index.....	0007 00
Troubleshooting Procedures	0008 00

TABLE OF CONTENTS – continued

CHAPTER 4 – OPERATOR MAINTENANCE INSTRUCTIONS

Service Upon Receipt.....	0009 00
Operator Preventative Maintenance Check And Services (PMCS), Introduction.....	0010 00
Operator Preventative Maintenance Check And Services (PMCS), Procedures.....	0011 00
Operator Maintenance, Introduction.....	0012 00
Heater Body Base	0013 00
Top Heater Shell	0014 00
Adapter Ring (Type I, Solid Fuel).....	0015 00
Grate Assembly (Type I, Solid Fuel)	0016 00
Stack Cap Assembly	0017 00
Flue Damper (Type I, Solid Fuel)	0018 00
Spark Arrester (Type I, Solid Fuel).....	0019 00
Stack Pipe Assembly.....	0020 00
Burner Shell And Burner Cap Assemblies (Type II, Liquid Fuel)	0021 00
Superheater Assembly (Type II, Liquid Fuel).....	0022 00
Hose Assemblies (Type II, Liquid Fuel).....	0023 00
High Fire Ring (Type II, Liquid Fuel)	0024 00
Cup And Cable Assembly (Type II, Liquid Fuel)	0025 00
Fuel Flow Control Valve (Type II, Liquid Fuel)	0026 00
Gravity Feed Adapter (Type II, Liquid Fuel)	0027 00

CHAPTER 5 – UNIT MAINTENANCE INSTRUCTIONS

Unit Preventative Maintenance Check And Services (PMCS), Introduction	0028 00
Unit Preventative Maintenance Check And Services (PMCS), Procedures.....	0029 00
Heater Body Base Door Latches.....	0030 00
Adapter Ring (Type I, Solid Fuel).....	0031 00
Round And Draw Grates (Type I, Solid Fuel).....	0032 00
Stack Cap Assembly	0033 00
Heater Body Base (Type II, Liquid Fuel)	0034 00
Burner Shell Assembly (Type II, Liquid Fuel).....	0035 00
Flow Control Burner Hose (Type II, Liquid Fuel).....	0036 00
High Fire Ring (Type II, Liquid Fuel)	0037 00
Cup And Cable Assembly (Type II, Liquid Fuel)	0038 00
Fuel Flow Control Valve (Type II, Liquid Fuel)	0039 00

CHAPTER 6 - SUPPORTING INFORMATION

References.....	0040 00
Maintenance Allocation Chart	0041 00
Repair Parts And Special Tools List, Introduction.....	0042 00
Repair Parts And Special Tools List – Group 01 Type I (Solid Fuel)	0043 00
Repair Parts And Special Tools List – Group 02 Type II (Liquid Fuel).....	0044 00
Repair Parts And Special Tools List – Group 03 Fuel Can Stand.....	0045 00
Repair Parts And Special Tools List – Group 04 Bulk Materials List.....	0046 00
National Stock Number Index.....	0047 00
Part Number Index	0048 00
Special Tools List	0049 00
Components Of End Item (COEI) List & Basic Issue Items (BII) List.....	0050 00
Additional Authorization List.....	0051 00
Expendable And Durable Items List.....	0052 00
Illustrated List Of Manufactured Items.....	0053 00

Alphabetical Index.....	Index 1
-------------------------	---------

TM 9-4520-257-12&P

HOW TO USE THIS MANUAL

This Manual contains General Information, Operating Instructions, Operator Preventive Maintenance Checks and Services (PCMS), Troubleshooting, and Maintenance/Repair instructions for the Large Radiant Space Heater (H-45).

Chapter 1 contains introductory information on the H-45 and its associated equipment as well as a Theory of Operation. Chapter 2 includes operating instructions under usual and unusual conditions. Chapter 3 contents include operator troubleshooting, PMCS, and service procedures. Chapter 4 contains Unit Maintenance instructions. Chapter 6 contains references and other supporting information. Chapter 6 also includes the Repair Parts and Special Tools List (RPSTL) which identifies those parts or tools which are unique to the operation and maintenance of this equipment.

Manual Organization and Page Numbering System. The Manual is divided into six major chapters that detail the topics mentioned above. Within each chapter are work packages covering a wide range of topics. Each work package is numbered sequentially starting at page 1. The work package has its own page numbering scheme and is independent of the page numbering used by other work packages. Each page of a work package has a page number of the form XXXX YY-ZZ where XXXX is the work package number (e.g. 0010 is work package 10) and YY is the revision number for that work package and ZZ represents the number of the page within that work package. A page number such as 0010 00-1/2 blank means that page 1 contains information but page 2 of that work package has been intentionally left blank.

Finding Information. The Table of Contents permits the reader to find information in the manual quickly. The reader should start here first when looking for a specific topic. The Table of Contents lists the topics contained within each chapter and the Work Package Sequence Number where it can be found.

Example: If the reader were looking for instructions on "Preventive Maintenance Checks and Services", which is a Operator Maintenance topic, the Table of Contents indicates that Operator Maintenance information can be found in Chapter 3. Scanning down the listings for Chapter 3, "Preventive Maintenance Checks and Services" information can be found in WP 0010 00 (i.e. Work Package 10).

An Alphabetical Index can be found at the back of the Manual, and lists specific topics with the corresponding work package.

THIS PAGE INTENTIONALLY LEFT BLANK

**OPERATOR AND UNIT MAINTENANCE
H-45 LARGE RADIANT SPACE HEATER
(TYPE I, SOLID FUEL)
NSN 4520-01-354-1191
(TYPE II, LIQUID FUEL)
NSN 4520-01-329-3451
GENERAL INFORMATION**

SCOPE

This manual covers the operation of, as well as operator and unit maintenance procedures for, the H-45 Type I (Solid Fuel) and Type II (Liquid Fuel) Large Radiant Space Heaters. They are designed to heat personnel tents and are capable of operating on a variety of fuels as specified in Work Package (WP) 0002 00. Both types are fielded as safe and versatile heat sources for Army field operations.

The H-45 Type I (Solid Fuel) Heater components include the heater body base (1), top heater shell (2), stack pipe with spark arrester (3), stack pipe with flue damper (4), stack cap with guy lines (5), heater lid (6), shaker (7), poker (8), and shovel (9).

The H-45 Type II (Liquid Fuel) Heater components include the heater body base (10), top heater shell (11), a fuel flow control valve (12), stack pipe (13), heater lid (14), fuel supply hose (15), fuel overflow hose (16), flow control burner hose (17), reaming tool (18), stack cap with guy lines (19), gravity feed adaptor (20), and fuel can stand (21).

Both types accommodate the use of the optional Thermoelectric Fan (TEF) (22).

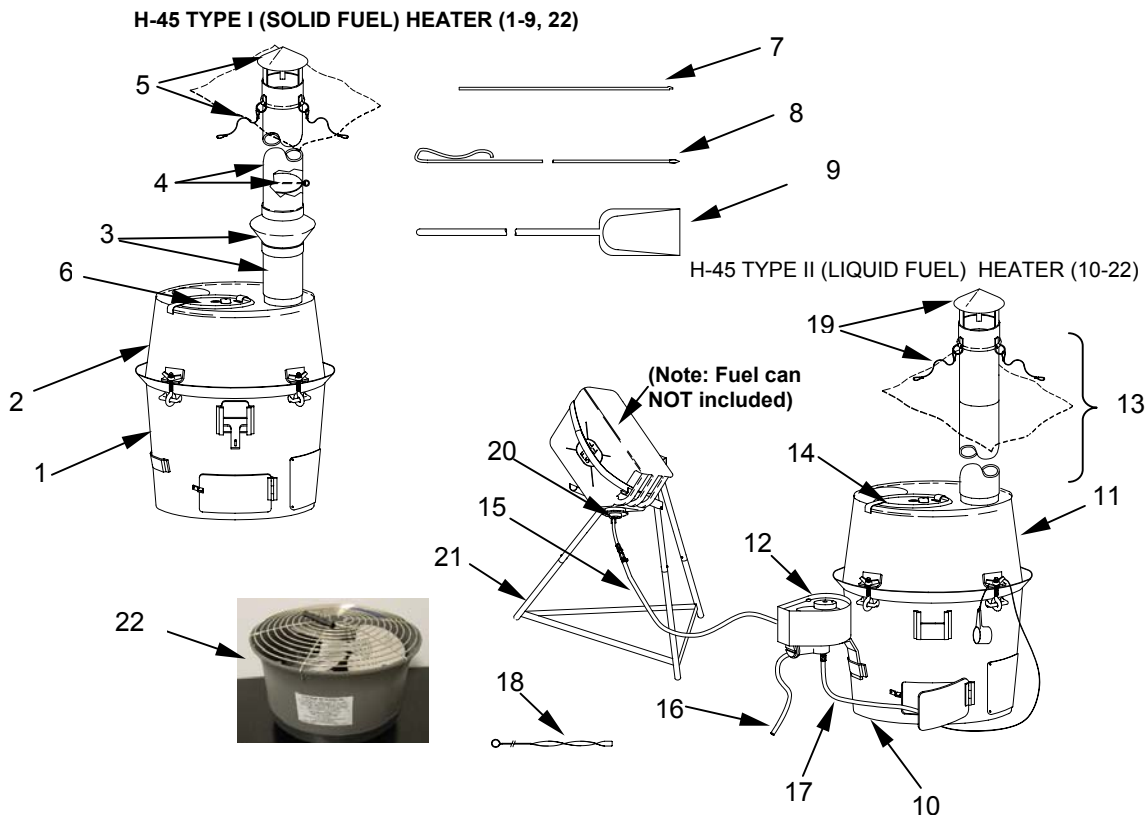

TYPE OF MANUAL: Operator and Unit Maintenance.

MODEL NUMBER AND EQUIPMENT NAME: Heater, Space, Radiant, Large (H-45) - Type I (Solid Fuel), NSN 4520-01-354-1191 and Type II (Liquid Fuel), NSN 4520-01-329-3451.

PURPOSE OF EQUIPMENT: Both types of the H-45 Large Radiant Space Heaters provide heat output in a range from 20,000 to 45,000 British thermal units per hour (BTU/hr). Both types are designed to be used in medium- to large-sized shelters in moderate to arctic conditions. The Type I version of the H-45 is designed to operate with solid fuel while the Type II operates with liquid fuel.

MAINTENANCE FORMS RECORDS AND REPORTS

Department of the Army (DA) forms and procedures used for equipment maintenance will be those prescribed by DA Pamphlet (DA PAM) 738-750, Functional Users Manual for the Army Maintenance Management System (TAMMS); DA PAM 738-751, Functional Users Manual for the Army Maintenance Management System-Aviation (TAMMS-A); or Army Regulation (AR) 700-138, Army Logistics Readiness and Sustainability. Marine Corps users refer to the current edition of Technical Manual (TM) 4700-15/1F.

REPORTING EQUIPMENT IMPROVEMENT RECOMMENDATIONS (EIRs)

If your H-45 needs improvement, let us know. Send us an EIR. You, the user, are the only one who can tell us what you don't like about your equipment. Let us know why you don't like the design or performance. Put it on a Standard Form (SF) 368, Product Quality Deficiency Report. Mail it to: Commander; U.S. Army Soldier and Biological Chemical Command; ATTN: AMSSC-I-LO; Kansas St.; Natick, MA 01760-5052. Marine Corps users should use an SF 368. Submit the completed SF 368 to: Commander; Marine Corps Logistics Bases (Code 856); Albany, GA 31704-5000. We will send you a reply.

CORROSION PREVENTION AND CONTROL (CPC)

Corrosion prevention and control (CPC) of Army materiel is a continuing concern. It is important that any corrosion problems with the H-45 be reported so that the problem can be corrected and improvements can be made to prevent the problem in future items.

While corrosion is typically associated with rusting of metals, it can also include deterioration of other materials, such as rubber or plastic. Unusual cracking, softening, swelling, or breaking of these materials may be a corrosion problem.

If a corrosion problem is identified, it can be reported using an SF 368, Product Quality Deficiency Report. Use of key words such as "corrosion," "rust," "deterioration," or "cracking" will ensure that the information is identified as a CPC problem. This form should be submitted to the address specified in DA Pam 738-750.

DESTRUCTION OF ARMY MATERIEL TO PREVENT ENEMY USE

For procedures to destroy this equipment to prevent its use by the enemy refer to TM 750-244-3, Procedures for Destruction of Equipment to Prevent Enemy Use. Marine Corps users refer to Office of the Chief of Naval Instruction (OPNAVINST) 5510.1H.

PREPARATION FOR STORAGE AND SHIPMENT

Prepare the equipment for storage or shipment as described in WP 0005 00.

Placement of equipment in administrative storage should be for short periods of time when a shortage of maintenance resources exists. Items should be mission-ready within 24 hours or within the time factors as determined by the directing authority. During the storage period appropriate maintenance records will be kept.

Before placing equipment in administrative storage, scheduled lubrication and preventive maintenance checks and services (PMCS) should be performed, shortcomings and deficiencies should be corrected, and all modification work orders (MWOs) should be applied.

Inside storage is preferred for items selected for administrative storage. If inside storage is not available, trucks, vans, shipping containers, and other containers may be used.

NOMENCLATURE CROSS-REFERENCE LIST

Common Name	Official Name
Flow Adjustment Knob	Metering Knob
Flow Control Burner Hose	Hose Assembly, Flow Control-Burner
Fuel Can	Can, Gasoline, Military
Fuel Flow Control Valve	Control, Multifuel Flow, Oil Burner Assembly
Fuel Overflow Hose	H45 Overflow Hose
Fuel Supply Hose	Hose Assembly Supply to Flow Control
Heater Body Base	Baseplate, Space Heater
H-45 Type I (Solid Fuel) Heater	Heater, Space, Radiant, Large, (H-45) (Type I, Solid Fuel)
H-45 Type II (Liquid Fuel) Heater	Heater, Space, Radiant, Large, (H-45) (Type II, Liquid Fuel)
Petroleum Absorbent Mat	Absorbent Material, Oil and Water
Thermoelectric Fan (TEF)	Heater Fan

LIST OF ABBREVIATIONS/ACRONYMS

°C	degrees Celsius
°F	degrees Fahrenheit
AAL	additional authorization list
AR	Army regulation
BII	basic issue items
BOI	basis of issue
BTU/hr	British thermal units per hour
CAGEC	commercial and Government entity code
cm	centimeter
COEI	component of end item
CPC	corrosion prevention and control
CTA	common table of allowance
DA	Department of the Army
DF	diesel fuel
DMWR	depot maintenance work requirement
EIR	equipment improvement recommendations
EMP	electromagnetic pulse
FIG	figure

LIST OF ABBREVIATIONS/ACRONYMS - Continued

FM	field manual
HCI	hardness critical item
JP	jet propulsion
JTA	joint table of allowances
kg	kilogram
MAC	maintenance allocation chart
MSDS	material safety data sheet
MTOE	modified table of organization and equipment
MWO	modification work order
NBC	nuclear, biological, and chemical
NIIN	national item identification number
NSN	national stock number
OPNAVINST	Office of the Chief of Naval Operations Instruction
P/N	part number
PAM	pamphlet
PMCS	preventive maintenance checks and services
QD	quick disconnect
RPSTL	repair parts and special tools list
SF	standard form
SHA	Space Heater, Arctic
SMR	source, maintenance, and recoverability
SRA	specialized repair activity
TAMMS	The Army Maintenance Management System
TAMMS-A	The Army Maintenance Management System-Aviation
TB	technical bulletin
TDA	table of distribution and allowances
TEF	Thermoelectric Fan
TM	technical manual
TMDE	test, measurement, and diagnostic equipment
TOE	table of organization and equipment
U/M	unit of measure
UI	unit of issue
UOC	usable on code
UUT	unit under test
WP	work package

SAFETY, CARE AND HANDLING, WARNINGS, CAUTIONS, AND NOTES

Always pay attention to Warnings, Cautions, and Notes appearing throughout the manual. They will appear prior to applicable procedures. Ensure you read and understand their content to prevent serious injury to yourself and others or damage to equipment.

END OF WORK PACKAGE

CHAPTER 1
DESCRIPTION AND THEORY OF OPERATION
FOR THE
H-45 LARGE RADIANT SPACE HEATER

THIS PAGE INTENTIONALLY LEFT BLANK

OPERATOR AND UNIT MAINTENANCE
H-45 LARGE RADIANT SPACE HEATER
(TYPE I, SOLID FUEL)
NSN 4520-01-354-1191
(TYPE II, LIQUID FUEL)
NSN 4520-01-329-3451
EQUIPMENT DESCRIPTION AND DATA

EQUIPMENT CHARACTERISTICS, CAPABILITIES, AND FEATURES

Fuel For The H-45 Type I (Solid Fuel) Heater

The H-45 Type I (Solid Fuel) Heater is designed to operate safely with either wood or coal.

Fuel For The H-45 Type II (Liquid Fuel) Heater

WARNING



Used motor oil, solvents, and other unauthorized fuels should **NOT** be used with the H-45 Type II (Liquid Fuel) Heater under any circumstance. **Only approved liquid and solid fuels may be used. Gasoline and JP-4 should be used only in emergency situations when there is no other fuel available and when the soldier's health and unit readiness are in jeopardy.** Using gasoline, JP-4, or unauthorized fuels in the H-45 Type II (Liquid Fuel) Heater will create a fire danger and potential for explosion.

The H-45 Type II (Liquid Fuel) Heater incorporates a burner that vaporizes liquid fuel, which enhances combustion efficiency and prevents flooding. It is designed to operate with the following fuels in the order listed.

- Jet propulsion (JP) fuel: JP-8
- Diesel fuel (DF): DF-A, DF-1, or DF-2
- JP-5
- Kerosene
- Jet A-1
- Jet A
- Gasoline (**emergency only**)
- JP-4 (**emergency only**)

Likenesses Of The H-45 Type I and Type II Characteristics, Capabilities, And Features

CHARACTERISTICS	CAPABILITIES AND FEATURES
<p>Both Types</p> <p>Modular</p> <p>Multipurpose</p> <p>Portable</p> <p>Self-contained</p>	<p>Both Types</p> <p>Operate without the use of electrical power.</p> <p>Produce between 20,000 and 45,000 BTU/hr.</p> <p>Have an operator instruction plate mounted on heater body base; however, the instruction plate only applies when using the heater in the liquid fuel mode.</p> <p>Type I – Solid Fuel Operates with either wood or coal.</p> <p>Type II – Liquid Fuel Operates with a variety of liquid fuels: JP-8; DF-A, DF-1, or DF-2; JP-5; kerosene; Jet A-1; Jet A; gasoline (emergency only); JP-4 (emergency only)</p> <p>Uses 5-gallon fuel can. (Not provided.)</p> <p>Has a fuel shut-off valve.</p>

Major Components Of The H-45 Type I (Solid Fuel) Heater

Heater assembly. The H-45 Type I (Solid Fuel) Heater consists of a heater body base (1) and a top heater shell (2). The heater body base (1) serves as a base for the assembled heater and houses the grates (3) during operation. Two heater body base doors (4) are cut into the heater body base (1) at opposite positions to allow air for combustion. Three evenly spaced bolt and wing nut assemblies (5) are welded to the heater body base (1). Three evenly spaced brackets (6) are welded to the top heater shell. The three bolt and wing nut assemblies (5) secure the top heater shell (2) to the heater body base (1) when the bolts are slid into the brackets (6) and the wing nuts are tightened. During the operation of the H-45 Type I (Solid Fuel) Heater, the top heater shell (2) is placed onto the heater body base (1) and secured. The top heater shell (2) has one internally flanged, 9-inch (22.86-centimeter (cm)) circular cutout (7) to accommodate the lid (8), and one externally flanged 4-inch (10.16-cm) cutout (9) that serves as mounting for the stack pipe sections (10).

Grates and adapter ring. Two grates (3) that hold solid fuel are held together by a cotter pin and supported by an adapter ring (11) that mounts on the heater body base (1).

Exhaust system. The exhaust system consists of six stack-pipe sections (10) connected end to end, leading from the 4-inch (10.16-cm) externally flanged circular cutout (9) on the top heater shell (2) through the tent roof (12). A flue damper (13) controls airflow, while a spark arrester (14) provides fire safety. The stack pipe is topped by a stack cap assembly (15), to which three wire ropes and guy lines (16) are attached to provide stability.

Accessories. The shaker (17) and poker (18) are included to aid in tending the burning fuel inside the H-45. The shaker (17) can be used to access the shaker catch through the grate heater door (20) and shake the grate in order to move the ashes into the lower portion of the heater. The poker (18) is used to move live fuel around in the top heater shell. The shovel (19) is used to remove ashes from the lower section of the heater.

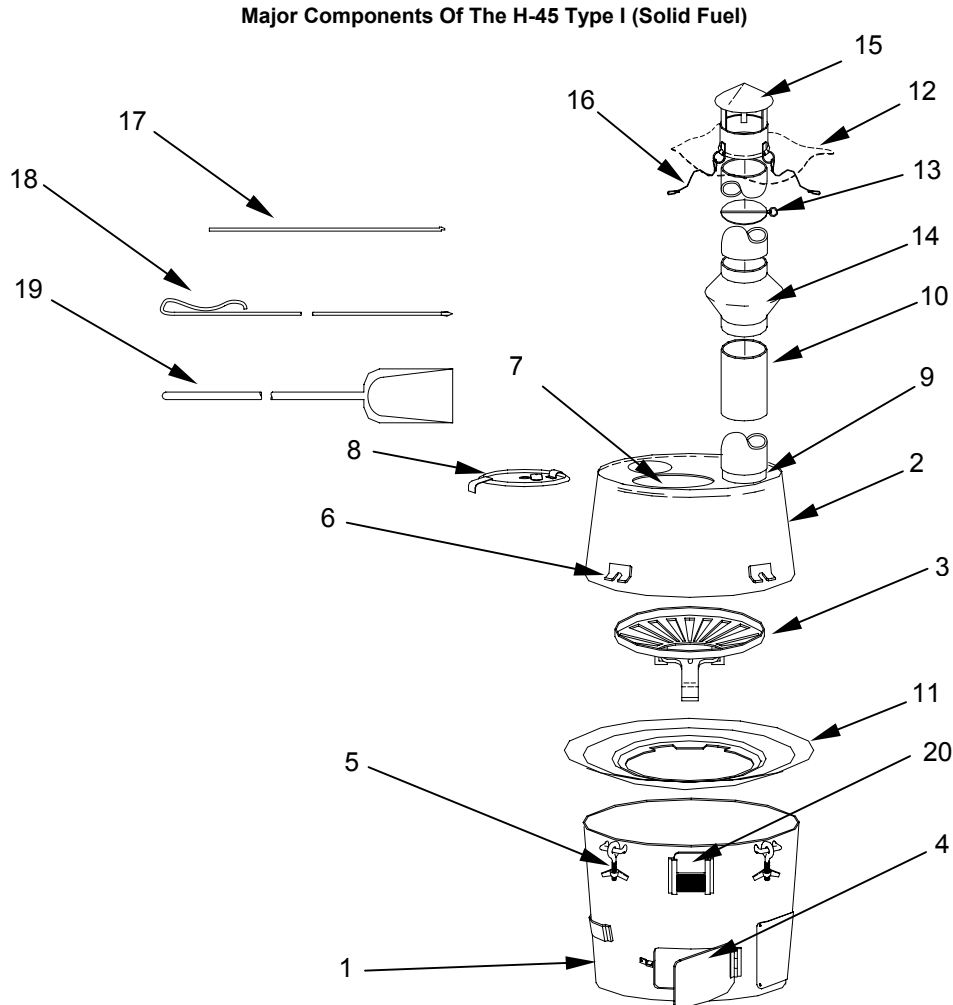

Major Components Of The H-45 Type II (Liquid Fuel) Heater

Heater assembly. The Type II (Liquid Fuel) Heater assembly consists of a heater body base (1) and a top heater shell (2). The heater body base (1) serves as a base for the assembled heater. It houses the burner shell assembly (3) during operation. Two heater body base doors (4) are cut into the heater body base (1) at opposite positions to allow air for combustion. A support (5) to hold the fuel flow control valve bracket (6) is welded adjacent to the front heater body base door. Three evenly spaced bolt and wing nut assemblies (7) are welded to the heater body base (1). Three evenly spaced brackets (8) are welded to the top heater shell (2). The three bolt and wing nut assemblies (7) secure the top heater shell (2) to the heater body base (1) when the bolts are slid into the brackets (8) and the wing nuts are tightened. During the operation of the H-45 Type II (Liquid Fuel) Heater, the top heater shell (2) is placed onto the heater body base (1) and secured. The top heater shell (2) has one internally flanged, 9-inch (22.86-centimeter (cm)) circular cutout (9) to accommodate the lid (10), and one externally flanged 4-inch (10.16-cm) cutout (11) that serves as mounting for the stack pipe sections (12).

Burner shell assembly and adapter ring. The burner shell assembly (3) fits into the heater body base (1). It consists of a rolled steel pot (13) with a high fire ring (14), a burner cap assembly (15), and a superheater assembly (16). An adapter ring (17) that engages the upper rim of the heater body base (1) is welded to the burner shell assembly (3). The high fire ring (14) is held in place by three clamps (18) that attach to the adapter ring (17) with pan head screws. A cleaning tool (19) is used to clean soot and any buildup from the inside of the up-tube and down-tube.

Fuel flow control valve. The fuel flow control valve (20) is mounted on the side of the heater body base (1). The fuel flow control valve (20) is designed to function with JP-8; DF-A, DF-1, or DF-2; JP-5; kerosene; Jet A-1; Jet A; gasoline (**emergency only**); and JP-4 (**emergency only**). It has several orifices to match the various viscosities of the fuels being used. The orifices are cut to permit a maximum and minimum flow rate consistent with the safe operation of the heater.

Exhaust system. The exhaust system consists of six stack-pipe sections (12) connected end to end, leading from the 4-inch (10.16-cm) externally flanged circular cutout (11) on the top heater shell (2), through the tent roof (21), and topped by a stack cap assembly (22), to which three wire ropes and guy lines (23) are attached to provide stability.

Hose assemblies. The hose assemblies conduct fuel from the fuel source to the fuel flow control valve (20), from the fuel flow control valve (20) to the burner shell assembly (3), and from the fuel flow control valve (20) to the overflow area.

Major Components of the H-45 Type II (Liquid Fuel) Heater

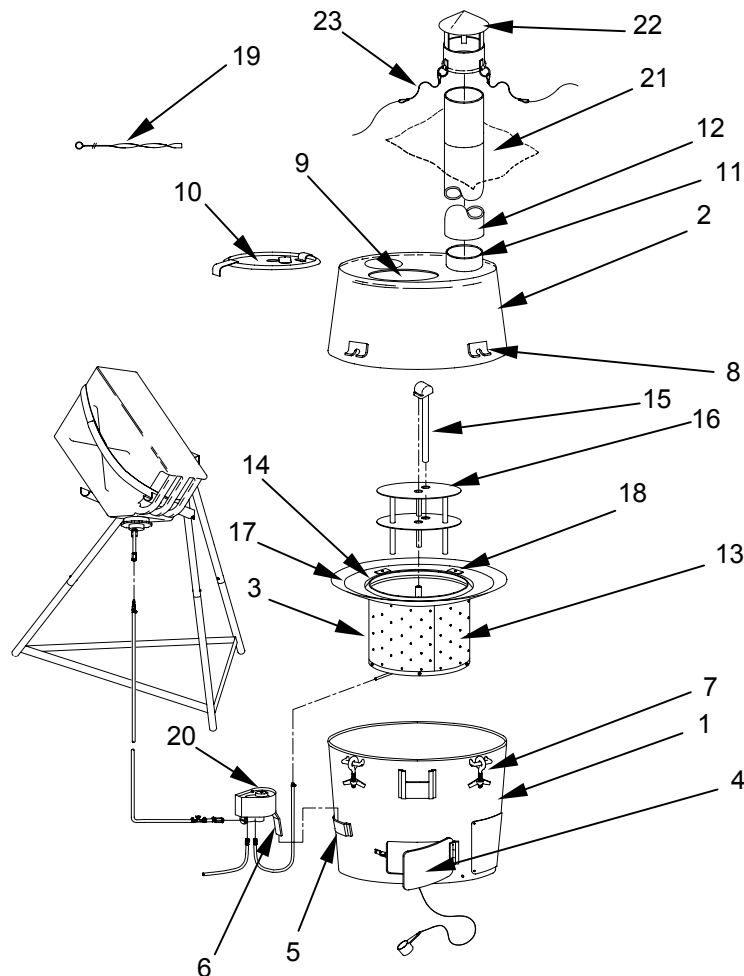

Associated components. The associated components of the H-45 Type II (Liquid Fuel) Heater are illustrated and described as follow:

Fuel Supply Hose. The fuel supply hose connects between the fuel can gravity feed adaptor and the fuel flow control valve. It supplies fuel to the H-45. A "T" connector with petcock permits fuel to be drained off into the measuring cup for priming.

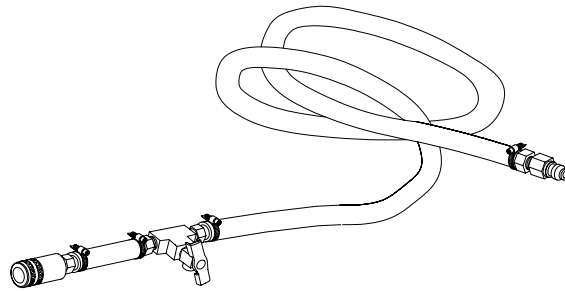

Fuel Overflow Hose. The fuel overflow hose connects to the fuel flow control valve and allows any overflow fuel to be sent outside the shelter.

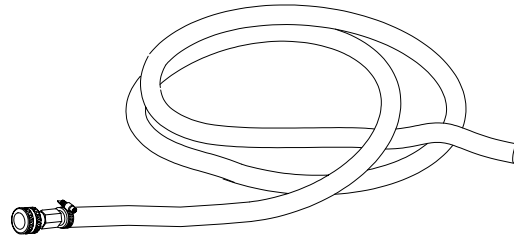

Flow Control Burner Hose. The flow control burner hose connects to the fuel flow control valve and supplies the fuel to the burner shell assembly.

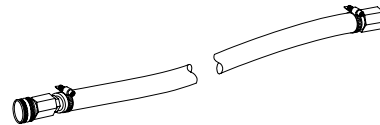

Fuel Can Stand. The fuel can stand supports a standard plastic fuel can in an inverted position in order to gravity feed fuel to the heater. The stand disassembles and folds for packing.

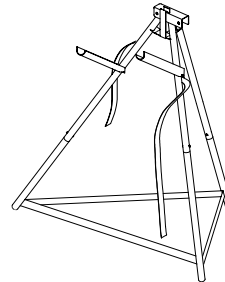

Gravity Feed Adapter. This adapter installs in a standard issue plastic fuel can and permits fuel to flow by gravity from the fuel can to the H-45 Type II (Liquid Fuel) Heater.

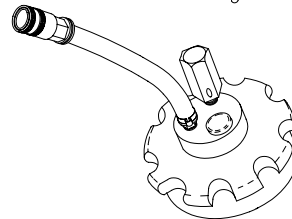

Thermoelectric Fan (TEF), Optional

The TEF is an optional component of both the H-45 Type I (Solid Fuel) and Type II (Liquid Fuel) Heaters. The TEF generates its own power from the heat generated by the heaters and is placed on the indented area on the top heater shell of the H-45s. The fan is available as an additional authorized item as detailed in WP 0051 00.



H-45 Components. Table 1 lists the components for the Type I and Type II heaters.

Table 1. H-45 Components By Type

Components	Type I (Solid Fuel)	Type II (Liquid Fuel)
Top heater shell	X	X
Heater body base	X	X
Grates	X	
Hose assemblies		X
Burner shell assembly		X
Adapter ring	X	
Elbow fitting		X
High fire ring		X
Burner cap assembly		X
Superheater assembly		X
Fuel flow control valve		X
Stack cap assembly	X	X
Stack pipe	X	X
Flue damper	X	
Spark arrester	X	
Shaker, poker, shovel	X	
Burner reaming tool		X

EQUIPMENT DATA

The following technical and identification data pertains to the H-45 and selected support equipment.

Material Specification Data

Weight:

H-45 Type I (Solid Fuel)	
Set up	62 pounds (28.12 kg)
Shipping	72 pounds (32.66 kg)
H-45 Type II (Liquid Fuel)	
Set up	65 pounds (29.48 kg)
Shipping	75 pounds (34.02 kg)

Dimensions:

Height	24 ⁵ / ₈ inches (62.55 cm)
Width	18 ⁵ / ₈ inches (47.32 cm)

Performance Specification Data

WARNING



Fire or Explosion

Do not use motor oil, cleaning solvents, or any other fuel not authorized for use in the H-45. Use of an unauthorized fuel may result in fire or explosion.

Fuel Types Usable For Heater Operation:

Solid Fuel Mode Wood, coal
Liquid Fuel ModeJP-8; DF-A, DF-1, DF-2; JP-5; kerosene; Jet A-1; Jet A; gasoline **(emergency only)**; JP-4 **(emergency only)**

Liquid Fuel Consumption:

Rate of fuel consumption at maximum firing rate:
DF-1, DF-2 0.6 gallons/hour (37.85 cubic centimeters/minute)
JP-5, JP-8, DF-A 0.63 gallons/hour (39.74 cubic centimeters/ minute)

Outputs:

Burner firing rate (setting dependent)..... 20,000 to 45,000 BTU/hr

Environmental:

Operating temperatures -60°F to +50°F (-51°C to +10°C)
Operating elevations to 6,000 feet above sea level

COMMON TOOLS AND EQUIPMENT

For authorized common tools and equipment, refer to the Modified Table of Organization and Equipment (MTOE); Common Table of Allowances (CTA) 50-970, Expendable/Durable Items (Except: Medical, Class V, Repair Parts, and Heraldic Items); or CTA 8-100, Army Medical Department Expendable/Durable Items, as applicable to your unit.

There are no special tools; test measurement and diagnostic equipment (TMDE); and support equipment for the H-45.

Repair parts are listed and illustrated in the repair parts and special tools lists (RPSTLs) located in WP 0042 00 through WP 0046 00.

END OF WORK PACKAGE

THIS PAGE INTENTIONALLY LEFT BLANK

OPERATOR AND UNIT MAINTENANCE
H-45 LARGE RADIANT SPACE HEATER
 (TYPE I, SOLID FUEL)
 NSN 4520-01-354-1191
 (TYPE II, LIQUID FUEL)
 NSN 4520-01-329-3451
THEORY OF OPERATION

GENERAL

The H-45 Large Radiant Space Heaters are designed to be operated by one soldier; however it may take two or more soldiers to assemble and tie down the stack assembly. The H-45 Type I (Solid Fuel) Heater is designed to use wood or coal for fuel. The H-45 Type II (Liquid Fuel) Heaters can be fueled by JP-8; DF-A, DF-1, or DF-2; JP-5; kerosene; Jet A-1; Jet A; gasoline (**emergency only**); and JP-4 (**emergency only**). Safe operation of the heaters requires adherence to all operating instructions and careful monitoring of the heaters during operation. Both Type I (Solid Fuel) and Type II (Liquid Fuel) combustion gases are exhausted out of the roof of the shelter.

SOLID FUEL OPERATION

CAUTION

Do not overfill the heater when using coal or wood as a solid fuel. Coal is very dense and produces a very high heat output. Using too much coal or wood in the heater will over fire the unit and make it very difficult to control the heat output.

For the H-45 Type I (Solid Fuel) Heater, paper and kindling (such as small pieces of wood) are laid on the grate (1). When the kindling is burning, wood or coal is added. Heat output is regulated by the amount of fuel placed in the heater, by opening or closing the front and back base heater doors (2) in the bottom of the heater body base (3), and by adjusting the flue damper (4) in the stack pipe (5).

Combustion gases flow up the stack pipe (5), through the stack cap assembly (6), to the outside of the shelter.

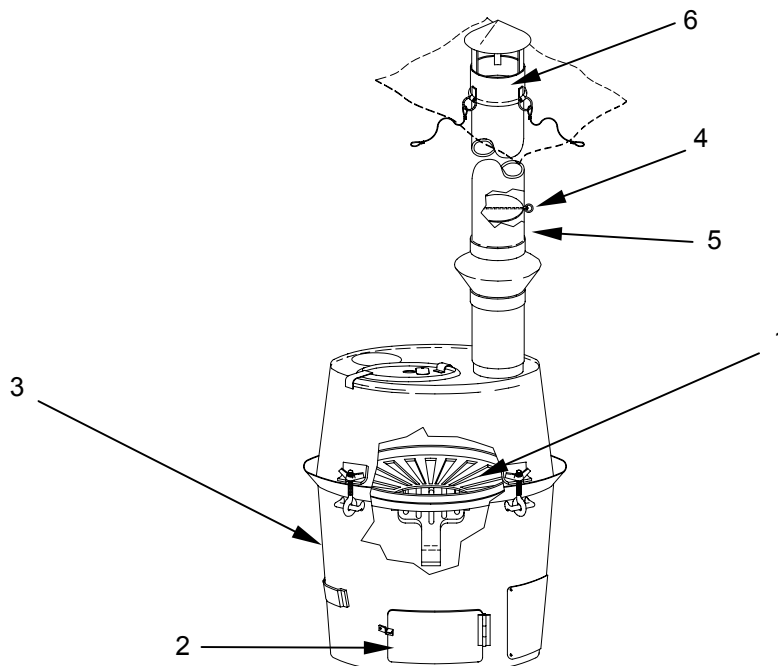

LIQUID FUEL OPERATION**WARNING**

Used motor oil, solvents, and other unauthorized fuels should **NOT** be used with the H-45 Type II (Liquid Heater) under any circumstance. **Only approved liquid and solid fuels may be used. Gasoline and JP-4 should be used only in emergency situations when there is no other fuel available and when the soldier's health and unit readiness are in jeopardy.** Using gasoline, JP-4, or unauthorized fuels in the H-45 will create a fire danger and potential for explosion.

For the Type II (Liquid Fuel) heater, JP-8; DF-A, DF-1, or DF-2; JP-5; kerosene; Jet A-1; Jet A; gasoline (**emergency only**); JP-4 (**emergency only**) fuel flows from the fuel source to the fuel flow control valve (1).

By selecting the appropriate fuel setting, one of three internal orifices (each one appropriately dimensioned to match the viscosity of the fuel being used) is activated. The liquid fuel then enters the burner up-tube (2) in the burner base.

The process of vaporization is initiated by the priming process, whereby a small amount of fuel is poured into the burner shell assembly (3) through the lid opening (4) and ignited.

The heat created by the priming process vaporizes the fuel in the burner up-tube (2) in 5 to 10 minutes. When the priming fuel is consumed, the vapor from the burner cap down-tube (5) will sustain the flame.

The desired fuel flow rate can then be selected with the fuel flow adjustment knob (6).

Combustion gases pass from the burner shell assembly (3) through the stack pipe assembly (7).

Heat output is controlled by positioning the fuel flow adjustment knob (6) on the fuel flow control valve (1), which limits the amount of fuel sent to the burner shell assembly (3) for combustion.

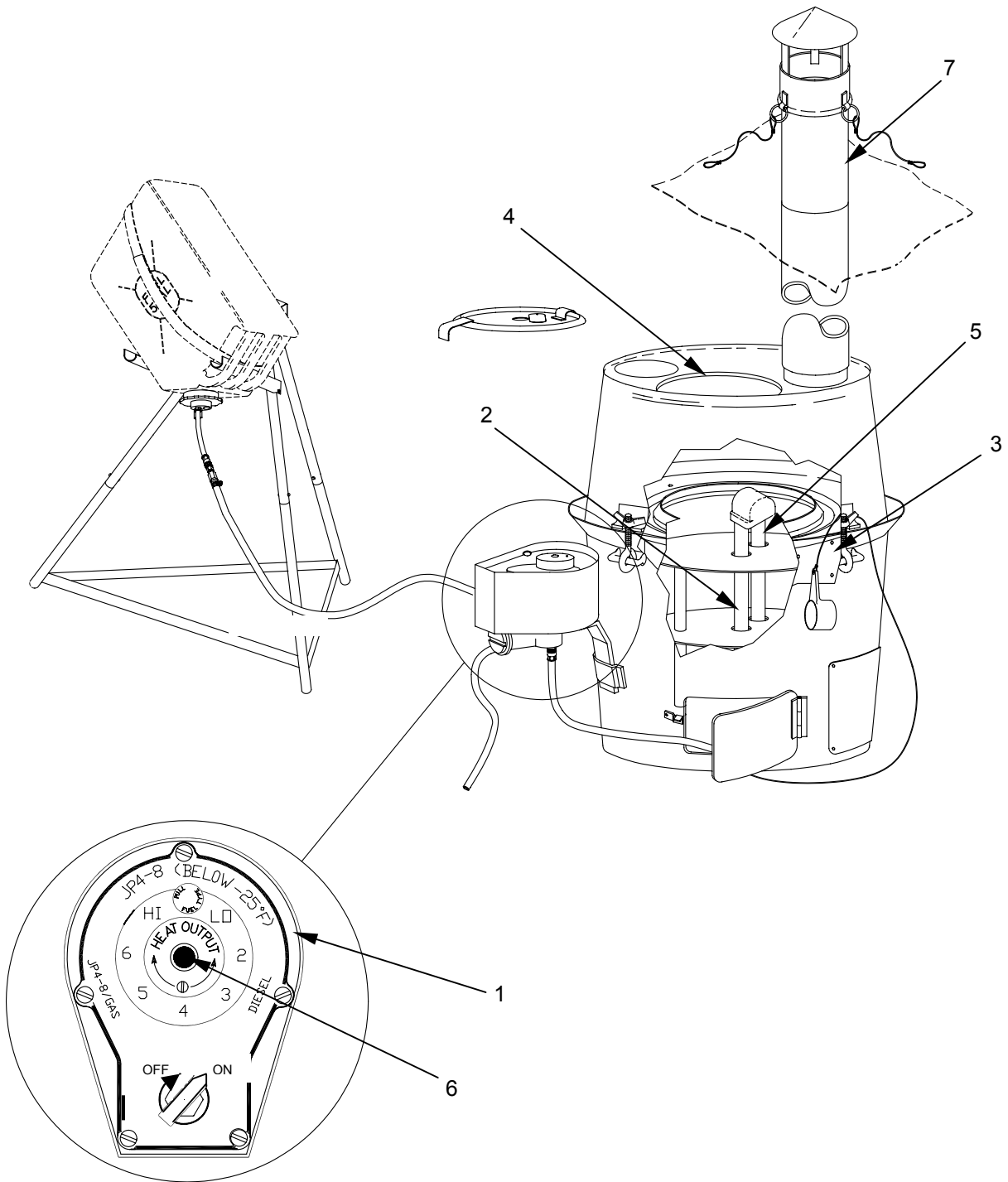

END OF WORK PACKAGE

THIS PAGE INTENTIONALLY LEFT BLANK

CHAPTER 2

**OPERATING INSTRUCTIONS
FOR THE
H-45 LARGE RADIANT SPACE HEATER**

THIS PAGE INTENTIONALLY LEFT BLANK

**OPERATOR AND UNIT MAINTENANCE
H-45 LARGE RADIANT SPACE HEATER
(TYPE I, SOLID FUEL)
NSN 4520-01-354-1191
(TYPE II, LIQUID FUEL)
NSN 4520-01-329-3451**

DESCRIPTION AND USE OF OPERATION CONTROLS AND INDICATORS

CONTROLS AND INDICATORS

The following illustrations and tables show and explain the location and function of each control and indicator on the H-45s and their associated equipment. Table 1 describes the controls and indicators for the H-45 Type I (Solid Fuel) Heater. Table 2 describes the controls and indicators for the H-45 Type II (Liquid Fuel) Heater.

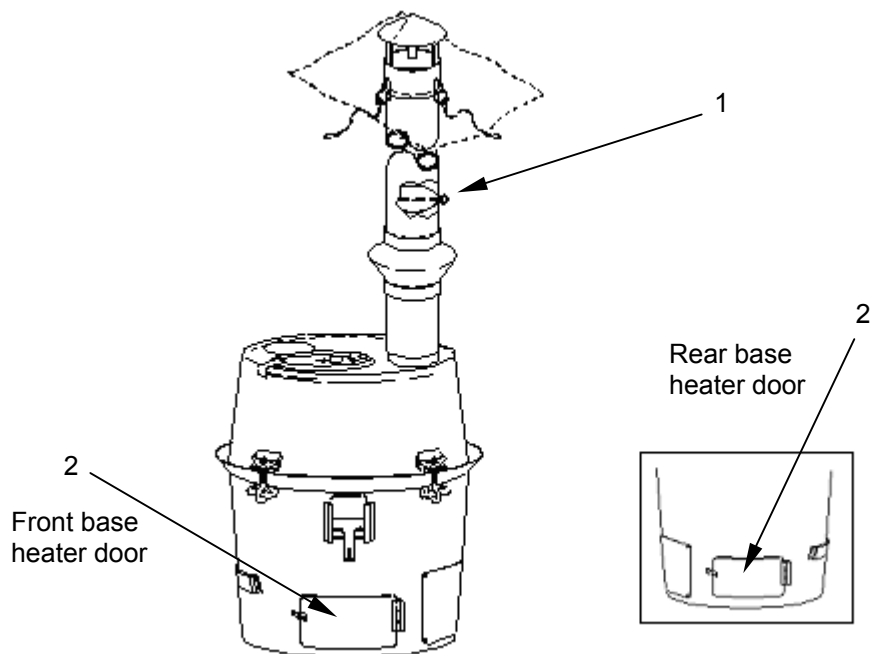

Table 1. H-45 Type I (Solid Fuel) Heater Controls and Indicators

Key	Item	Fuel mode	Function
1	Flue damper	Solid	Controls heat output by limiting the amount of exhaust exiting the burner.
2	Front and rear base heater doors	Solid	Control the heat output by limiting the amount of airflow into the burner.

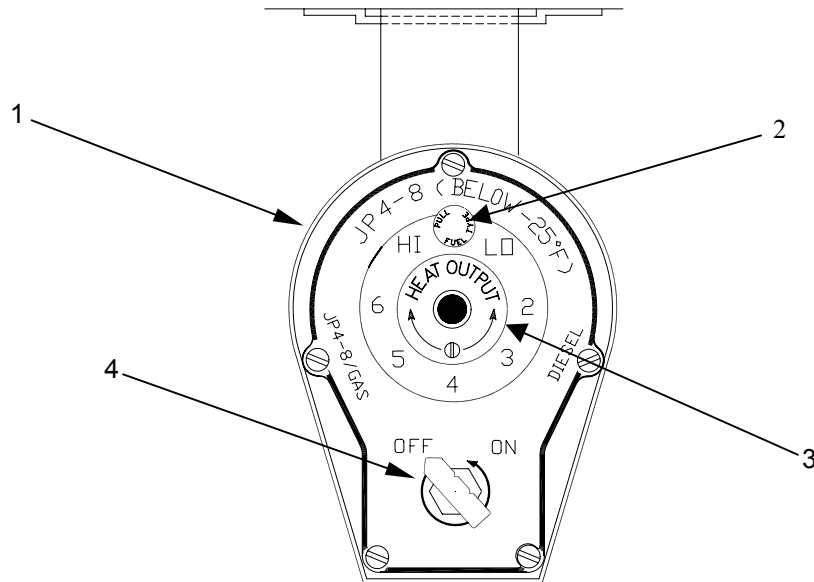

Table 2. H-45 Type II (Liquid Fuel) Heater Controls and Indicators

Key	Item	Fuel mode	Function
1	Fuel flow control valve	Liquid	Regulates the amount of fuel flowing to the burner.
2	Fuel selector control	Liquid	Sets the fuel flow control for ambient temperature and fuel type. This is done by pulling up the knob and rotating it to the proper fuel type and/or temperature setting. If the fuel type is not known, refer to the WP0005 section titled "Starting The H-45 Type II Heater" when the fuel type is not known. The selector control has the following settings: JP4-8/GAS (ABOVE -25°F) Used for JP4* through JP-8 fuels in ambient temperatures above -25°F (-32°C). Used for gasoline* fuel at any temperature. JP4-8 (BELOW -25°F) Used for JP4*-8 fuel in ambient temperatures below -25°F (-32°C). DIESEL Used for diesel fuel at any temperature.
3	Flow adjustment knob	Liquid	Controls the fuel flow from the float chamber to the burner.
4	Fuel on/off control	Liquid	Controls the fuel flow from fuel supply to fuel flow control valve.

* **JP4 and gasoline are to be used only under emergency conditions.**

FUEL SUPPLY, FUEL OVERFLOW, AND FLOW CONTROL BURNER HOSES

Table 3 describes the controls and indicators for the fuel supply and overflow hoses.

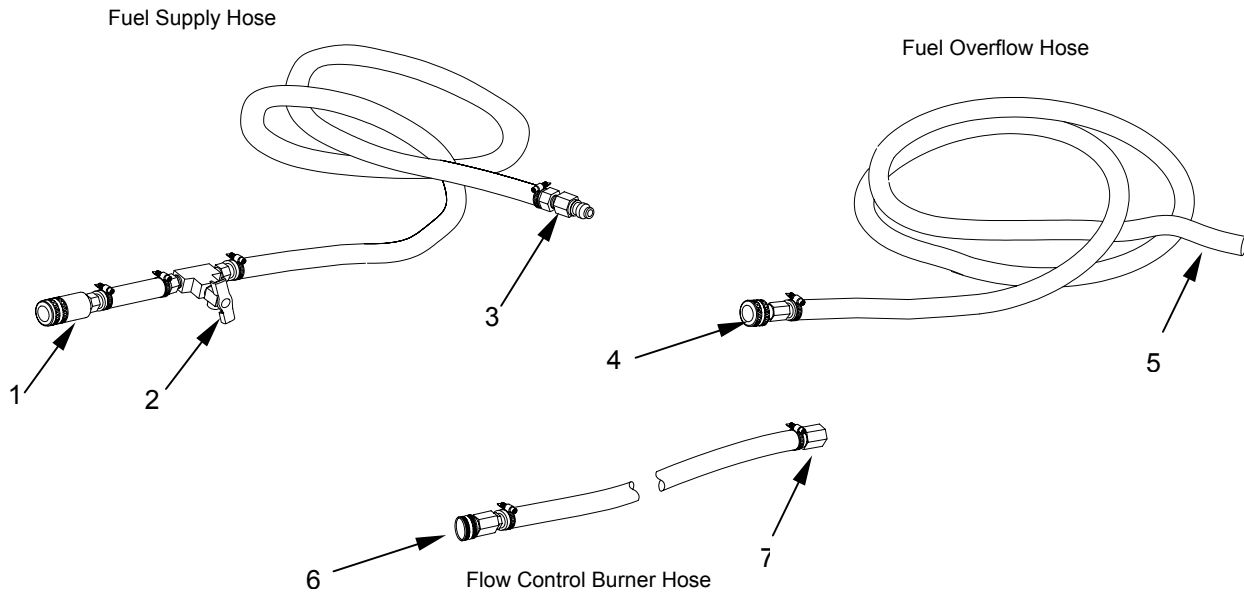

Table 3. Fuel Supply, Fuel Overflow, and Flow Control Burner Hose Controls and Indicators

Key	Control and indicator	Function
Fuel Supply Hose		
1	Female quick disconnect (QD) fitting of the fuel supply hose	Connects the fuel supply to the fuel flow control valve
2	"T" connector with petcock	Permits the fuel to be drained into the cup for priming
3	Male QD fitting of the fuel supply hose	Connects the fuel supply hose to the fuel can gravity feed adapter
Fuel Overflow Hose		
4	Female QD fitting of the fuel overflow hose	Connects to the fuel flow control valve to permit the excess fuel to drain
5	Open end of the fuel overflow hose	Placed outside of the shelter on a downslope to permit any overflow fuel to drain
Flow Control Burner Hose		
6	Female QD fitting of the flow control burner hose	Connects to the fuel flow control valve to permit fuel to reach the burner assembly
7	Hose barb connection of the flow control burner hose	Connects to the burner assembly

FUEL CAN STAND AND GRAVITY FEED ADAPTER

Table 4 describes the controls and indicators for the fuel can stand and the gravity feed adapter.

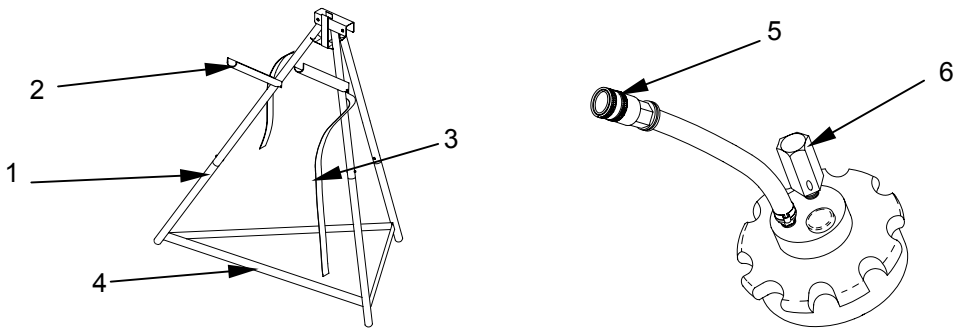

Table 4. Fuel Can Stand and Gravity Feed Adapter Controls and Indicators

Key	Control and indicator	Function
1	Fuel can stand leg assembly	Provides stable tripod to support fuel can
2	Fuel can supports	Supports fuel can when in feed position
3	Fuel can strap	Straps fuel can to stand
4	Fuel can stand stabilizer straps	Permits proper spacing of fuel can stand leg assembly
5	Gravity feed adaptor female QD connector	Connects fuel supply to fuel supply hose
6	Gravity feed adaptor manual relief valve	Allows air to vent into fuel can, permitting proper fuel flow

INSTRUCTION PLATE

NOTE

A plate containing abbreviated operating instructions is mounted on both the H-45 Type I (Solid Fuel) Heater and the H-45 Type II (Liquid Fuel) Heater body bases. However, the instructions only apply to the H-45 Type II (Liquid Fuel) Heater. Disregard this instruction plate when using the H-45 Type I (Solid Fuel) Heater.

Heater Body Base Abbreviated Operating Instruction Plate For Liquid Fuel Use Only

H45 HEATER ASSY P/N: 92878 - 45000
NSN: 4520-01-329-3451

1. SEE TECHNICAL MANUAL FOR DETAILED INSTRUCTIONS.
2. NEVER ATTEMPT TO LIGHT A BURNER WHILE IT IS HOT.
3. LIGHTING INSTRUCTIONS:
 ROTATE SELECTOR PIN ON VALVE TO MATCH FUEL, I.E. DIESEL, GAS OR JET.
 TURN VALVE SHUT OFF KNOB TO "ON".
 TURN VALVE CONTROL KNOB TO "H" AND WAIT 2-5 MIN.
 TURN VALVE CONTROL KNOB BACK TO #3.
 POUR 1 FOUR OZ. CUP OF DIESEL FUEL IN TO BASE OF BURNER.
 IGNITE PRIMING FUEL WITH LIGHTED TISSUE PAPER.
 USE END OF AUGER TO PLACE TISSUE ON BASE.
 NOTE: IF USING JP4 OR GASOLINE AS PRIMING FUEL, STAND BACK AND DROP IN LIGHTED MATCH.
 "WARNING" KEEP HANDS AND FACE AWAY FROM LID OPENING TO PREVENT BURNS.
 CLOSE LID-WAIT FOR BURNER TO WARM UP AND THEN ADJUST TO REQUIRED FLOW RATE.
4. NEVER OVER FIRE, NO SMOKE SHOULD BE SEEN FROM THE STACK.
5. REPAIR ALL LEAKS, BE SURE OVERFLOW LINE SLOPES DOWNWARD OUT OF TENT. IF FUEL FLOWS FROM OVERFLOW, REPLACE VALVE.
6. FOR WOODEN FLOOR, PLACE HEATER IN SAND BOX OR ON AN INSULATED MAT.

HUNTER Hunter Manufacturing Company
3626 Aurora Road
Tolson, ON M4P 1P9
www.hunterheater.com

OPERATING INSTRUCTIONS
H45 TENT HEATER

Fuel Flow Control Valve Side Label



Fuel Flow Control Valve Top Label

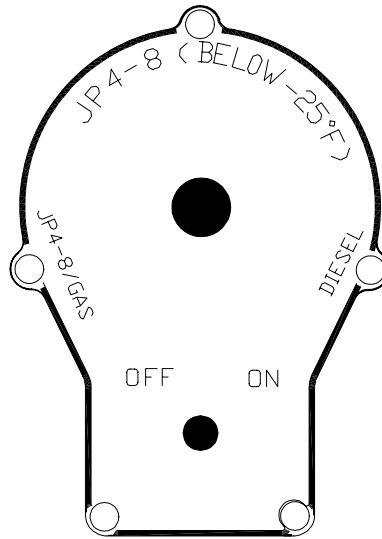

Thermoelectric Fan Labels (Optional Equipment, Refer To **WP 0053 00**)



THERMOELECTRIC FAN (TEF)
NSN 4520-01-457-2790

THIS FAN IS INTENDED TO CIRCULATE THE AIR AROUND A HEATER TO IMPROVE COMFORT AND REDUCE FUEL CONSUMPTION. IT DOES NOT REQUIRE EXTERNAL POWER. TO OPERATE, WAIT 15 MINUTES AFTER STARTING HEATER, REMOVE TEF FROM THE STORAGE CASE AND PLACE ON A FLAT HORIZONTAL SURFACE OF OPERATING STOVE OR HEATER (OR THE RECESSED INDENTATION ON THE TOP OF H-45 HEATER).

! CAUTION: ROTATING FAN !

DO NOT DROP. DO NOT INSERT FINGERS OR OTHER OBJECTS INTO FAN WHILE UNIT IS OPERATIONAL. DO NOT BLOCK AIR FLOW BY PLACING MITTS OR OTHER OBJECTS ON TOP OF THE WIRE GRILL. PLACING HOT FAN ON A SURFACE MAY RESULT IN DAMAGE, FIRE, OR INJURY.

THERMOELECTRIC FAN
NSN 4520-01-457-2790
Made in the USA by:
ASPEN SYSTEMS, INC. Marlborough, Massachusetts
www.aspensystems.com
CONTRACT # SP0560-00-D-5056
MODEL # TEF-III Serial # 5950



END OF WORK PACKAGE

**OPERATOR AND UNIT MAINTENANCE
H-45 LARGE RADIANT SPACE HEATER
(TYPE I, SOLID FUEL)
NSN 4520-01-354-1191
(TYPE II, LIQUID FUEL)
NSN 4520-01-329-3451
OPERATION UNDER USUAL CONDITIONS**

PREPARING THE H-45 TYPE I (SOLID FUEL) AND TYPE II (LIQUID FUEL) HEATERS FOR OPERATION

General

WARNING



The H-45 Type I (Solid Fuel) Heater, with the shipping container, weighs approximately 72 pounds (32.66 kg). The H-45 Type II (Liquid Fuel) Heater, with the shipping container, weighs approximately 75 pounds (34.02 kg). Two persons must carry either heater, lifting using their legs, not their backs, to prevent injury.

Servicing Prior To Operation

The heater unit should be clean and free of packing material prior to use. All operator PMCS should be accomplished prior to use. (See WP 0009 00 Service Upon Receipt for an inventory of heater parts, and see WP 0011 00 and WP 0029 00 PMCS requirements.)

WARNING



The metal surfaces of the H-45 heater body are shipped from the manufacturer with a protective film that must be burned off prior to the initial use of the heater in an enclosed area. Failure to do so could result in inhaling harmful fumes.

For procedures on burning off the protective film see the procedures outlined in this work package under the type of heater you are using or see WP 0009 00 Service Upon Receipt.

WARNING

Carbon monoxide gas is not visible and has no smell, but it can kill you. Breathing air with carbon monoxide can cause headaches, dizziness, loss of muscle control, a sleepy feeling, and coma. Brain damage or death can result from heavy exposure.

Carbon monoxide occurs when exhaust fumes from fuel-burning equipment, such as the H-45 heater, escape from defective or damaged stack pipes inside the tent. Carbon monoxide can reach dangerous concentrations under conditions of no air movement. Precautions must be followed to ensure crew safety when you operate this equipment. Inspect and replace any damaged or defective stack pipes that allow fumes to escape into the tent.

OPEN the tent vents to provide ventilation and prevent the accumulation of carbon monoxide gas.

BE ALERT at all times during heater operation for exposure symptoms.

IMMEDIATELY VENTILATE the tent. If symptoms persist, move affected crew to fresh air and keep warm.

DO NOT PERMIT PHYSICAL EXERCISE. If necessary, give artificial respiration.

FOR ARTIFICIAL RESPIRATION REFER TO FM 21-11.

THE BEST DEFENSE AGAINST CARBON MONOXIDE POISONING IS REPLACEMENT OF DAMAGED OR DEFECTIVE STACK SECTIONS AND GOOD VENTILATION.

H-45 TYPE I (SOLID FUEL) HEATER**Burning Off The Protective Film On The H-45 Type I (Solid Fuel) Heater Prior To Use****WARNING**

The metal surfaces of the H-45 heater body are shipped from the manufacturer with a protective film that must be burned off prior to the initial use of the heater in an enclosed area. Failure to do so could result in inhaling harmful fumes.

1. To burn off the protective film, you need to set up and operate the H-45 Type I (Solid Fuel) Heater in an open area outside of the tent. The following three sections of this work package describe "Preparing The H-45 Type I (Solid Fuel) Heater for Operation," "Assembling The Stack For H-45 Type I (Solid Fuel) Heater Operation," and "Starting The H-45 Type I (Solid Fuel) Heater."

NOTE

All six stack pipe sections must be assembled, put securely in place on the top heater shell flange, and tied down during the burnoff. Failure to use all six sections will adversely affect heater performance, increase soot buildup, and increase maintenance.

2. Once the heater is hot, you will see smoke coming off the metal surfaces as the protective film burns off. Allow the heater to burn until no more smoke is observed.
3. Shut down the heater, allow it to cool, and move it inside the tent. See the following sections in this work package: "Shutting Down The H-45 Type I (Solid Fuel) Heater" and "Preparing The H-45 Type I (Solid Fuel) Heater For Movement." Then repeat the instructions detailed in the sections listed in step 1 above.

Preparing The H-45 Type I (Solid Fuel) Heater For Operation

WARNING



If the heater has not been used before, you will have to completely assemble the heater outside of the tent (to include the six-section stack assembly and tie down), burn off the protective film as detailed previously in this work package, allow the heater to cool, disassemble the heater, and then move the heater inside the tent.

Make sure you allow enough air space between the tent walls and the heater unit, at least 4 feet (1.22 m). While in operation, the heater exterior will become very hot. Frequently check for heating of the tent walls while the heater unit is in use. If the tent walls become too hot, the heater needs to be shutdown, allowed to cool, and moved to a tent stack shield opening location farther away from the tent walls, if available, or the amount of solid fuel used in the heater needs to be decreased. Failure to follow these procedures could result in the heater igniting the tent.

NOTE

For best operation, be sure that the heater is as level as possible.

1. To prepare the H-45 Type I (Solid Fuel) Heater for operation (after the protective film has been burned off), place the heater on the ground under a tent stack shield opening. If used on top of a tent floor, the heater must be set on a bed of sand or placed on three or four bricks. Level the base by eye.

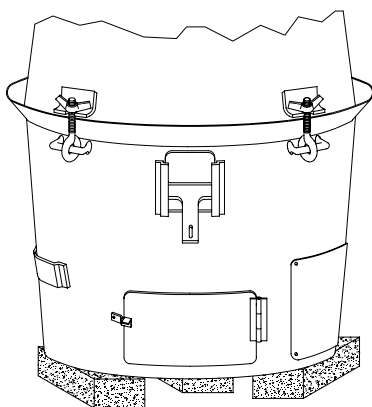
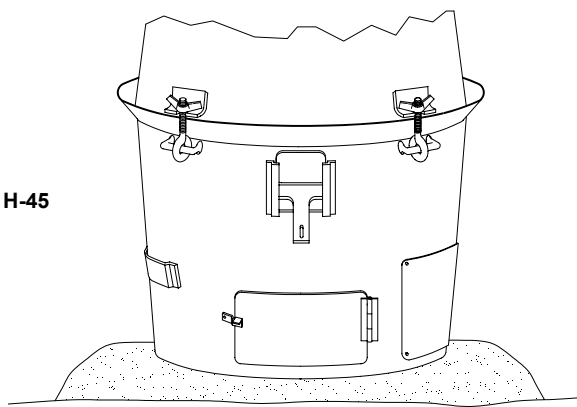
**BRICKS****LEVELING THE H-45****SAND**

2. Remove the top heater shell (7) from the heater body base (1) by loosening the wing nuts on the bolt and wing nut assemblies (8) and sliding the bolt and wing nut assemblies (8) out of the brackets (9) on the top heater shell (7). Set the top heater shell (7) aside. If not already done, remove all the components stored inside the heater. (See WP 0009 00 for an inventory of all the components.)
3. Place the adapter ring (2) on top of the heater body base (1).
4. Insert the grate assembly (3) into the adapter ring (2), with the draw grate (4) on the bottom of the assembly and the shaker catch (5) facing the grate heater door (6).
5. Place the top heater shell (7) on the heater body base (1). Slide the bolt and wing nut assemblies into the brackets (9) on the top heater shell (7) and tighten the wing nuts.

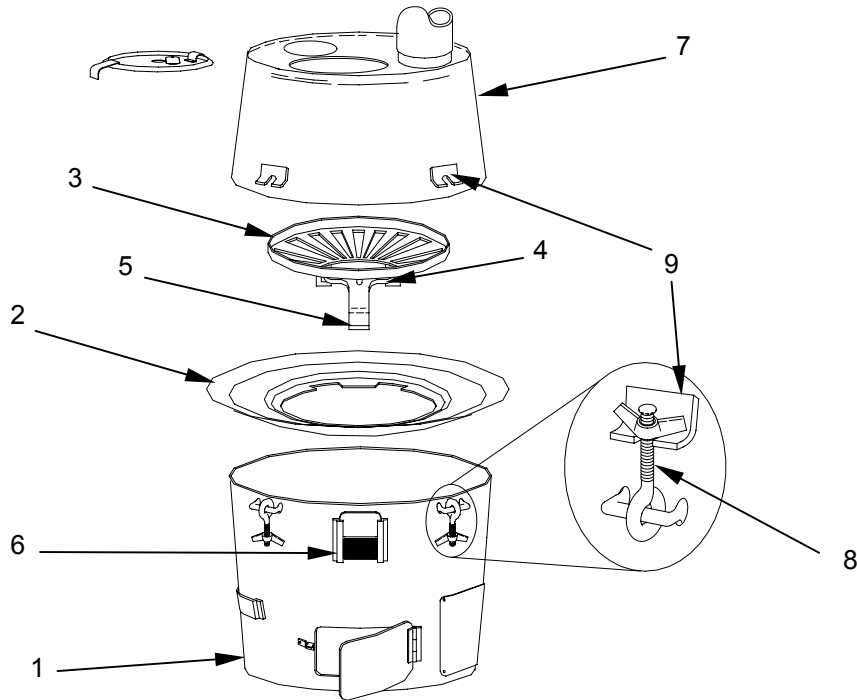

PREPARING THE H-45 TYPE I (SOLID HEATER) FOR OPERATION

Assembling The Stack For H-45 Type I (Solid Fuel) Heater Operation**WARNING**

Ensure the stack pipe sections seat together securely. Poorly fitted stack sections may allow a hot stack to fall on the tent and start a fire or allow deadly carbon monoxide to leak into the tent.

It is important to stake the exhaust stack securely. This will keep the exhaust stack vertical and seated firmly within the stack adapter with a downward force. This also stabilizes the heater and helps prevent it from being knocked over if bumped by equipment or people inside the tent. The tent needs to be securely staked to prevent the tent roof and walls from flapping during snowy and windy conditions. If the tent itself is not tightly staked, the roof and sidewalls can flap, getting close to the heater and creating a fire danger. (Refer to the tent-specific operator manual on the proper staking of the tent.)

During operation, the H-45 heater produces harmful carbon monoxide and other gases. Carbon monoxide is a colorless, odorless, and tasteless gas. Remember that although carbon monoxide has no telltale odor, it may mix with other odors that mask its presence; therefore, carbon monoxide can be present within a mix of seemingly harmless odors. Mild cases of carbon monoxide poisoning can cause symptoms such as nausea, dizziness, or headaches. Severe cases of carbon monoxide poisoning can result in brain damage, heart damage, or death.

To prevent carbon monoxide poisoning, ensure that the H-45 heater exhaust stack sections fit together snugly and that the exhaust gases are properly vented through the roof of the tent. Keep the H-45 heater in good working order. Ensure that all possible sources of carbon monoxide leakage have been repaired and that the operating space is well ventilated.

NOTE

All six stack pipe sections and stack cap assembly must be assembled, put securely in place on the top heater shell flange, and tied down during heater operation. Failure to use all six sections will adversely affect heater performance, increase soot buildup, and increase maintenance.

The type of tent, use of a step aid (if available), and height and strength of the persons assembling the stack may alter the following stack assembly procedures.

1. When the H-45 Type I (Solid Fuel) Heater is first delivered, the stack assembly sections are provided as curved sheet-metal sections. All six stack sections must be formed into cylinders and their seams locked. Refer to the section entitled "Assembling the Stack Sections for the H-45 Type I (Solid Fuel) Heater" in WP 0009 00 for information on assembling the sections before initial use.

2. When using the H-45 Type I (Solid Fuel) Heater, the flue damper must be installed in one of the stack pipe sections before the initial use of the heater. This procedure is detailed in the section entitled "Installing The Flue Damper" located in WP 0009 00.
3. Outside the tent, roll back the flap **(9)** on the tent stack shield opening **(8)**, and tie it back securely. (Refer to the tent-specific operator manual for this procedure.)
4. Inside the tent, securely install the uncrimped end of the spark arrester **(6)** onto the crimped end of one of the unaltered stack sections **(7)**.
5. Securely install the uncrimped end of the stack section containing the flue damper **(5)** onto the crimped end of the spark arrester **(6)**.
6. Assemble the remaining stack sections **(4-1)**.
7. Securely install the stack cap assembly **(10)** with attached guy lines **(11)** onto the crimped end of stack section **(1)**.
8. Insert the assembled stack with stack cap and attached guy lines through the tent stack shield opening **(8)**.
9. Securely install the uncrimped end of the stack section **(7)** containing the spark arrester **(6)** onto the flange **(12)** on the top heater shell **(13)**.
10. One person should remain in the tent stabilizing the stack assembly, while two other persons go outside the tent and retrieve the three guy lines **(11)** from the roof of the tent.

NOTE

The use of a long stick or other such object (not supplied with the H-45) may be needed to retrieve the guy lines from the tent roof. Once the guy lines are retrieved, additional lengths of rope (not supplied with the H-45) may have to be added to the end of each guy line before the ropes can be anchored to the stakes.

11. Outside the tent, drive three stakes (not supplied with the H-45 heater) into the ground, positioned evenly apart and a minimum of 2 feet (0.61 m) from the base of the tent. Space the guy lines **(11)** equally to ensure the stack is in a vertical and stable position. Securely anchor the guy lines **(11)** to the stakes ensuring that the lines are stretched tight. Ensure the guy lines and ropes DO NOT touch the roof or sides of the tent.

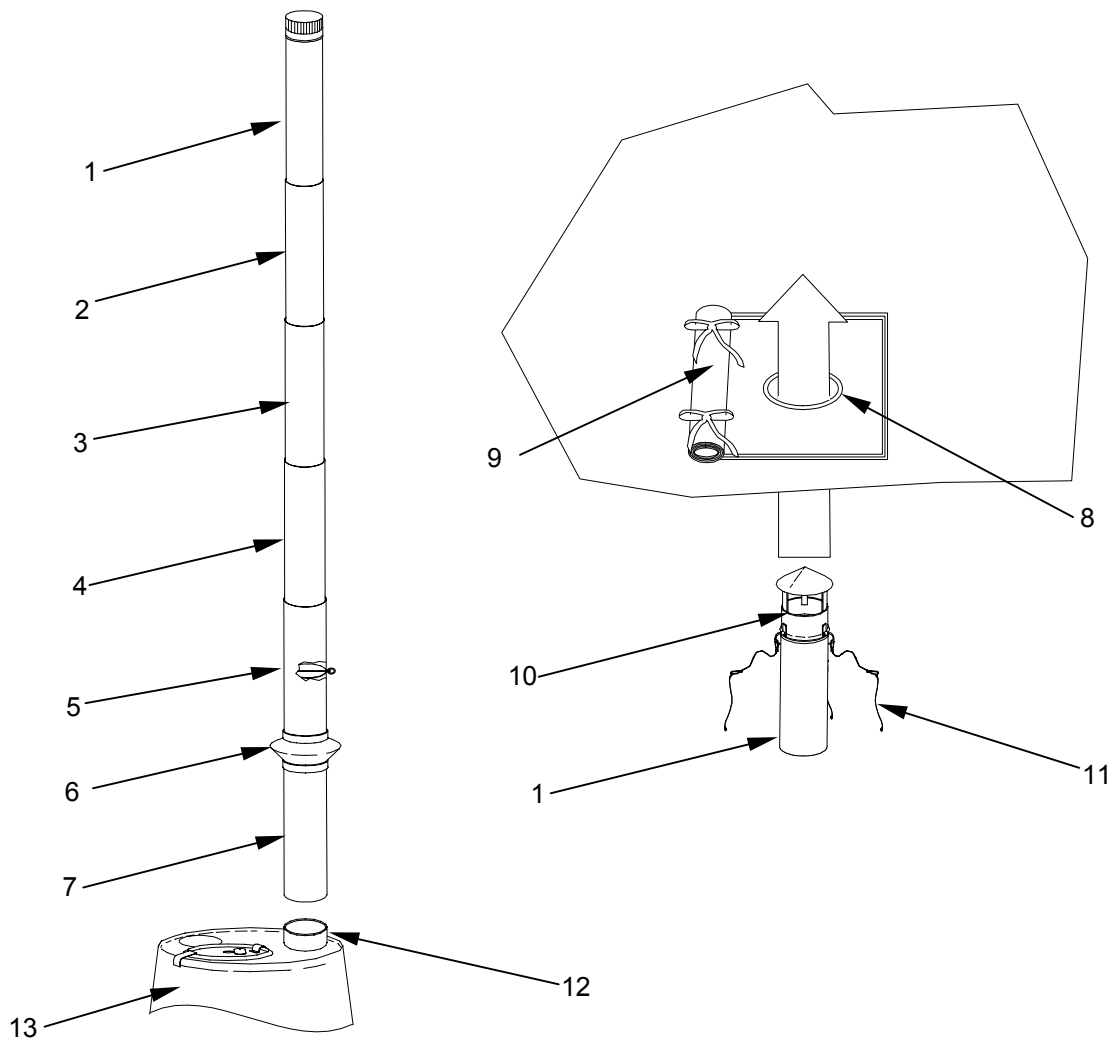

ASSEMBLING THE STACK FOR H-45 TYPE I (SOLID FUEL) HEATER OPERATION

Starting The H-45 Type I (Solid Fuel) Heater**WARNING**

Do not use gasoline or any other accelerant to assist in getting the H-45 Type I (Solid Fuel) Heater to burn. Using any type of accelerant may cause fire or explosion.

NOTE

Never close the damper completely while the H-45 Type I (Solid Fuel) Heater is in operation, and never leave a burning heater unattended.

1. To start the H-45 Type I (Solid Fuel) Heater, set the flue damper **(1)** in the open position. When open, the flue damper handle **(2)** will be parallel to the stack section **(3)**.
2. Open both the front and back base heater doors **(4)**.
3. Remove the heater lid **(5)**.
4. Put two or three pieces of crumpled paper **(6)** on the grate **(7)**.
5. Arrange a number of small pieces of wood **(8)** (such as kindling) in a crisscross fashion on top of the paper **(6)**. Ignite the paper **(6)**.
6. When the kindling **(8)** catches fire and is burning well, add some larger pieces of wood or, if burning coal, put one shovel (8 to 10 pieces, 2 to 3 inches or 5.08 to 7.62 cm in diameter) of coal on the kindling **(8)**.
7. When the coal or wood is burning well, replace the heater lid **(5)** and close the front and back base heater doors **(4)** halfway. Regulate the heat output by varying the front and back base heater doors **(4)** opening and by partially closing the flue damper **(1)** in the stack pipe. Never close the damper completely while the heater is in operation.
8. Remove the heater lid **(5)**, and add wood or coal at intervals to maintain a fire bed of approximately 3 inches (7.62 cm) in diameter on the grate through the heater lid **(5)**. Using the poker **(15)**, push the burning wood or coals to the rear of the heater lid opening, and add fresh wood or coal at the front of the heater lid opening. The escaping gases from the fresh coal will be burned off as they pass over the live coals. Add a shovel **(12)** of wood or coal after each previous shovel of wood or coal begins to burn, until the desired fire bed is reached. Never cover up all of the brightly burning wood or coal with fresh wood or coal.
9. To remove ashes and clinkers (such as burnt wood or coal), slide open the grate heater door **(10)** with the poker **(15)**, insert the shaker **(11)** in the shaker catch **(14)** on the draw grate **(9)**, and gently push the draw grate **(9)** back and forth with the shaker **(11)** until a faint red glow appears. Use the shaker sparingly. Do not extinguish the fire. Do not waste fuel by shaking burning wood and coals into the ash pit **(13)**. Leaving some ashes on the grate will protect the grate and help control the fire.

10. To prepare the heater for a long burn (such as overnight), put one shovel (12) of coal in the heater and adjust the front and back base heater doors (4) so they are open slightly. Partially close the damper (1). Never close the damper completely while the heater is in operation.

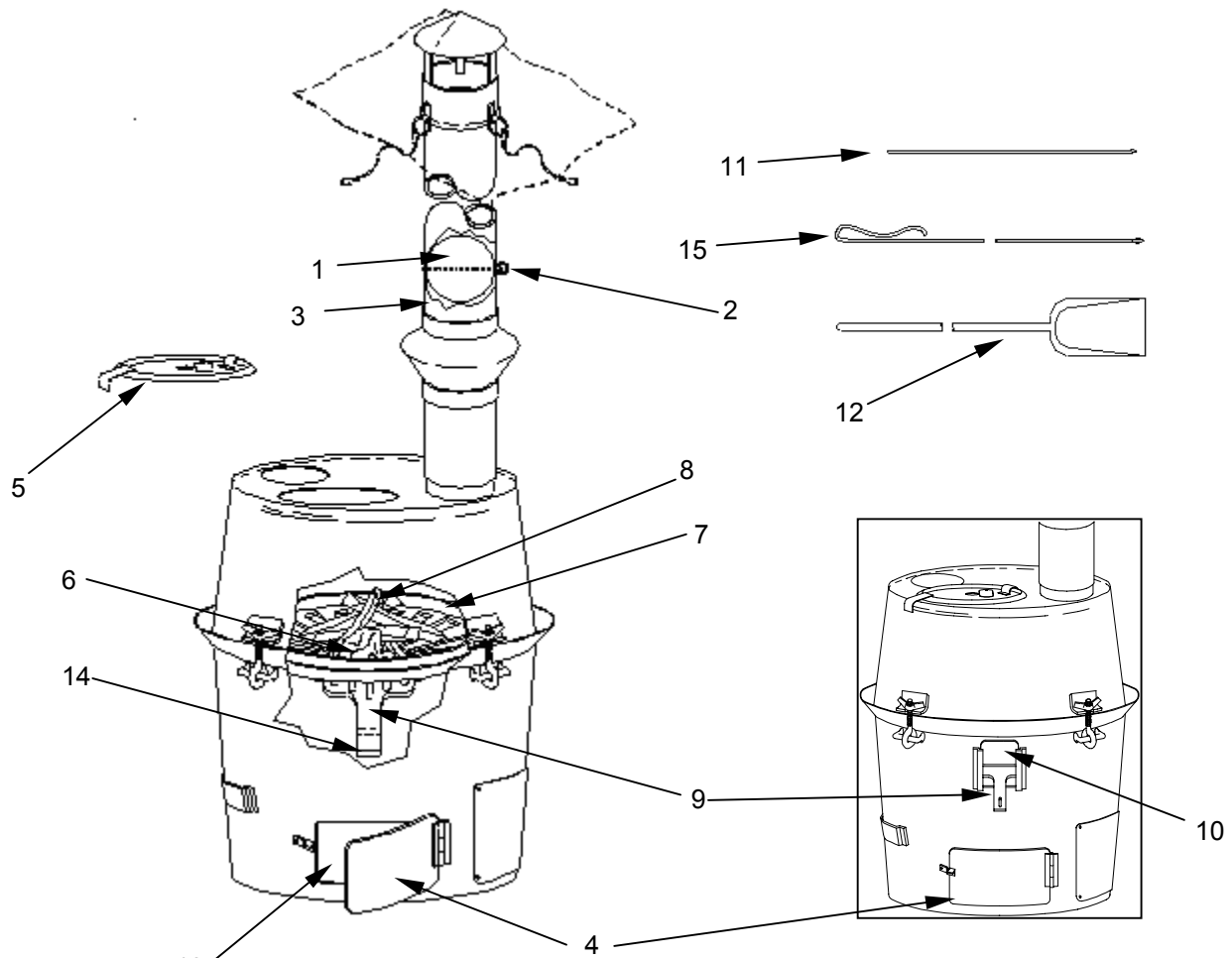

STARTING THE H-45 TYPE I (SOLID FUEL) HEATER

General Operating Characteristics Of The H-45 Type I (Solid Fuel) Heater

NOTE

The heater is designed to operate at various firing rates, producing between 20,000 to 45,000 BTU/hr. A smoking, pulsing, or sooty heater indicates an overfire or underfire condition.

Adjust the front and back base heater doors (4) and flue damper until the pulsing stops.

Shutting Down The H-45 Type I (Solid Fuel) Heater

1. To remove ashes and clinkers (such as burnt coal), slide open the grate heater door (1) using the poker (8), insert the shaker (3) in the shaker catch (5) on the draw grate (2), and gently push the draw grate (2) back and forth with the shaker (3). Shake the burning coals into the ash pit (4). The poker (8) can also be used through the lid opening (9) to move the coals around on the grate. The coals that are too large to shake into the ash pit must be allowed to burn until they can be shaken through the grate into the ash pit.
2. Fully open the front and back base heater doors (6), put the flue damper in the vertical position, and allow the burning coals to burn out. Once the coals and ashes are cold, use the shovel (7) to shovel them from the ash pit, and dispose of them outside the tent in an authorized disposal area.

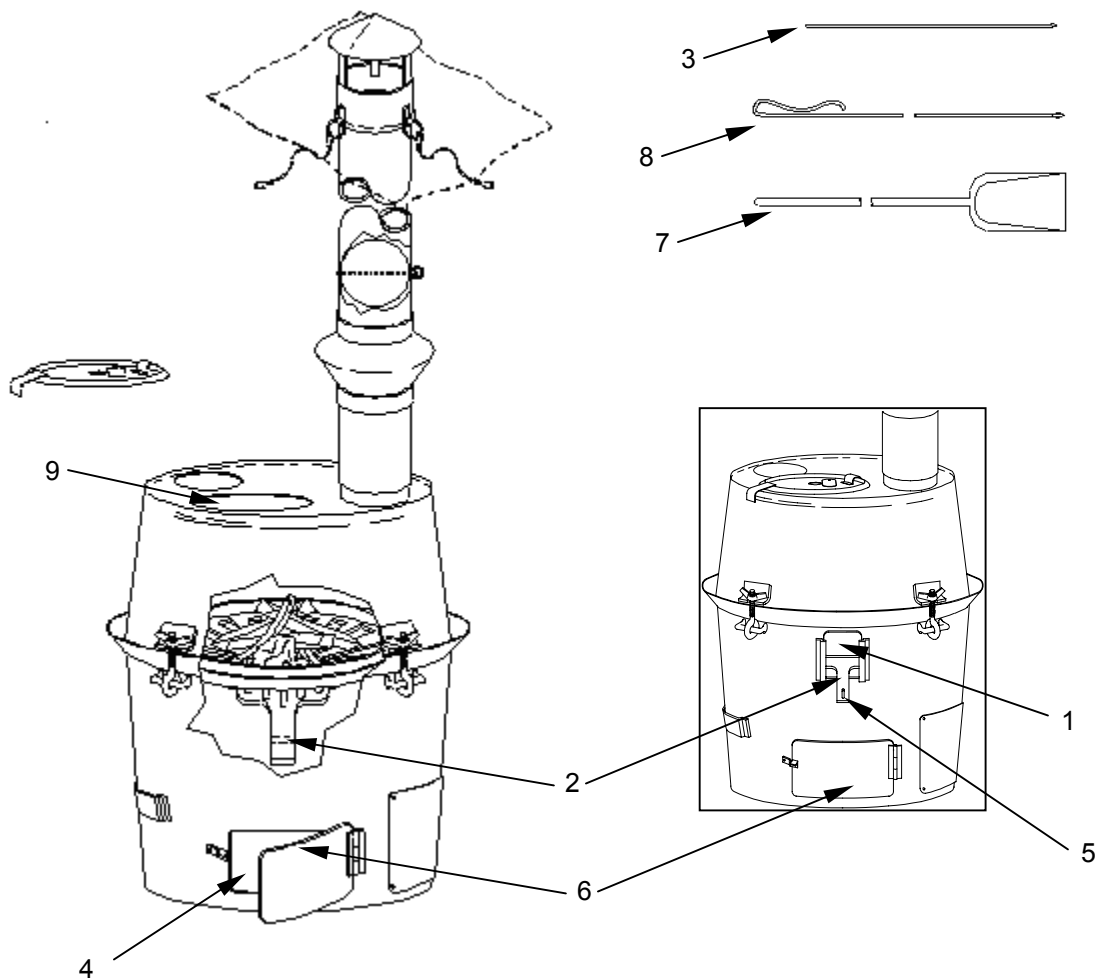

SHUTTING DOWN THE H-45 TYPE I (SOLID FUEL) HEATER

Preparing The H-45 Type I (Solid Fuel) Heater For Movement

WARNING



Do not attempt to disassemble a hot heater unit. Severe burns may result.

WARNING



The H-45 Type I (Solid Fuel) Heater with the shipping container, weighs approximately 72 pounds (32.66 kg). Two persons must carry the H-45 Type I (Solid Fuel) Heater, lifting using their legs, not their backs, to prevent injury.

NOTE

If the H-45 Type I (Solid Fuel) Heater is to be relocated within the same general location, it does not need to be completely disassembled. Only the stack needs to be disassembled. Two persons are needed to carry the equipment to the new position. If the heater is to be placed in storage, prepare the equipment in accordance with WP 0005 00.

1. Shutdown the H-45 Type I (Solid Fuel) Heater in accordance with the previous section of this work package, "Shutting Down The H-45 Type I (Solid Fuel) Heater," and let the heater cool completely.
2. Outside the tent, remove the guy lines **(1)** from the stakes. Stow the three stakes that were used to anchor the guy lines. (Refer to the tent-specific operator manual for stowing the stakes.)
3. Inside the tent, lift the stack assembly **(2)** from the stack flange **(3)** on the top heater shell **(8)**. Angle the stack assembly, while lowering the stack cap **(5)** with attached guy lines **(1)** through the tent stack shield opening **(6)**. Lay the stack assembly **(2)** on the tent floor.
4. Remove the spark arrester **(16)** from the bottommost stack and set it aside. Remove the stack cap **(5)** with attached guy lines **(1)** from the topmost stack section. Stuff the guy lines **(1)** inside the stack cap **(5)**, and set it aside. Separate the remaining stack sections, leaving the seams of the stack pipe sections sealed and set them aside.
5. Close the flap on the tent stack shield opening **(6)**. (Refer to the tent-specific operator manual for tent flap closure.)
6. Loosen the wing nuts on the bolt and wing nut assemblies **(7)** holding the top heater shell **(8)** to the heater body base **(9)**, remove the bolt and wing nut assemblies **(7)** from the brackets **(13)**, and remove the top heater shell **(8)**.

7. Remove the grates (10,11) and the adapter ring (12) from the heater body base (9).
8. Clean all components of soot, carbon buildup, and fuel residue using a rag and/or brush (not included).
9. Place the grates (10,11); lid assembly (14); shaker, poker, and shovel (15); spark arrester (16); stack cap with guy lines (5,1); adapter ring (12); and the stack section containing the flue damper (17) in the heater body base (9).

NOTE

The only stack section that is stored in the heater is the one containing the flue damper. The other five sections should be transported outside the heater.

10. Return the top heater shell (8) to the heater body base (9), place the bolt and wing nut assemblies (7) in the brackets (13), and tighten the wing nuts (7). Close the grate heater door (18) and close and lock the front and rear base heater doors (19).

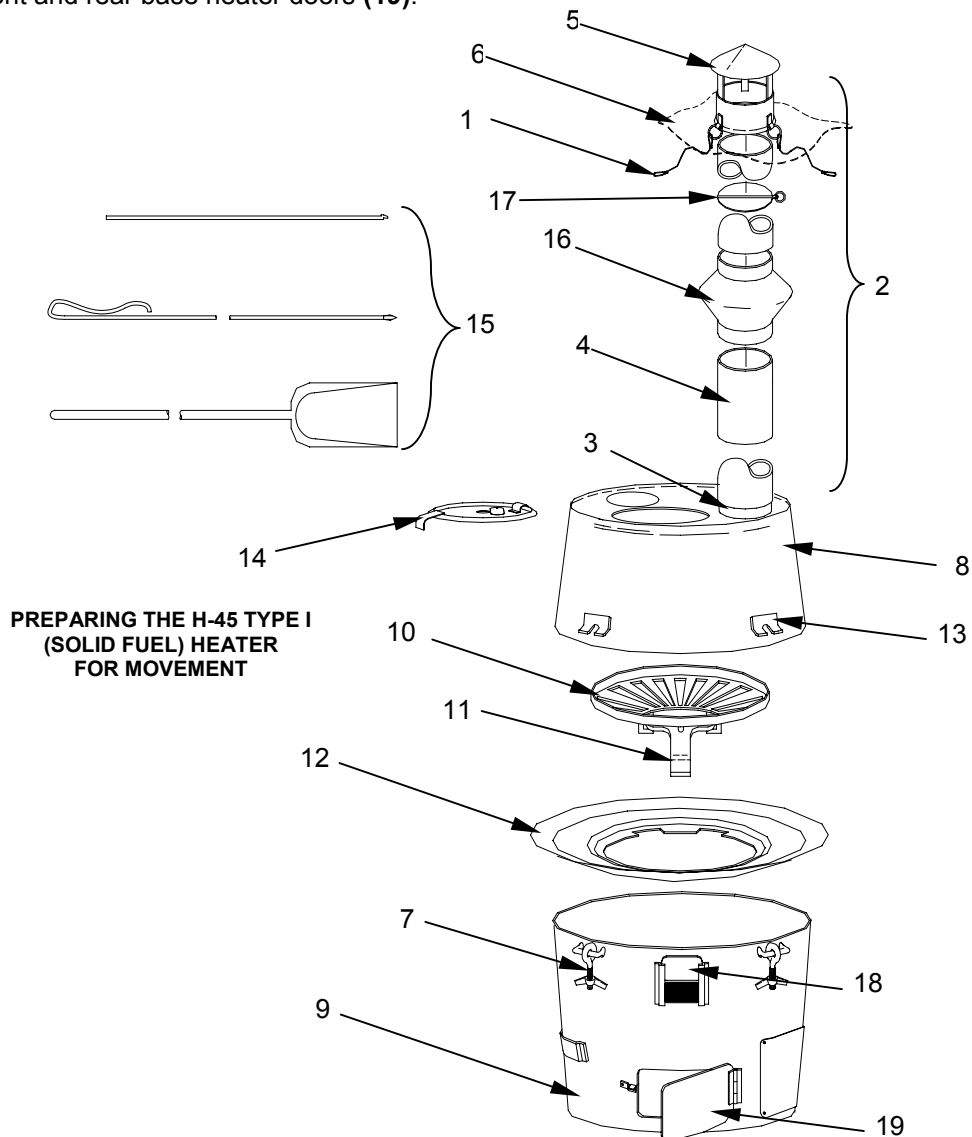

H-45 Type I (Solid Fuel) Heater Lubrication Requirements

The door hinges, door latch assemblies, bolt and wing nut assemblies, and sight glass cover on the heater lid should be lubricated with a light machine oil before storing the heater.

THE H-45 TYPE II (LIQUID FUEL) HEATER**Burning Off The Protective Film On The H-45 Type II (Liquid Fuel) Heater Prior To Use**

WARNING



The metal surfaces of the H-45 heater body are shipped from the manufacturer with a protective film that must be burned off prior to the initial use of the heater in an enclosed area. Failure to do so could result in inhaling harmful fumes.

NOTE

A piece of commercial petroleum absorbent material should be used to catch any fuel that may spill while connecting or disconnecting any hoses. Additional commercial products are available to contain large spills.

In the event that fuel is spilled on the ground, immediate action must be taken to contain the spill, and the appropriate environmental personnel should be notified.

Clean up any spilled fuel with a rag. Dispose of the rag and/or absorbent material in accordance with the local Material Safety Data Sheet (MSDS) procedure.

1. To burn off the protective film, you need to set up and operate the H-45 Type II (Liquid Fuel) Heater in an open area outside of the tent as described later in this work package.

NOTE

All six stack pipe sections must be assembled, put securely in place on the top heater shell flange, and tied down during the burnoff.

2. Once the heater is hot, you will see smoke coming off the metal surfaces as the protective film burns off. Allow the heater to burn until no more smoke is observed.
3. Shut down the heater, allow it to cool, and move it inside the tent. See the following sections in this work package: "Shutting Down The H-45 Type II (Liquid Fuel) Heater" and "Preparing The H-45 Type II (Liquid Fuel) Heater For Movement."

Preparing The Type II (Liquid Fuel) Heater For Operation**WARNING**

Flammable liquids are used in the operation of the heater. Death or severe injury may result from explosion or fire if personnel fail to observe the correct operating procedures for heater units.

WARNING

If the heater has not been used before, you will have to completely assemble the heater outside of the tent (to include the six-section stack assembly and tie down), burn off the protective film as detailed previously in this work package, allow the heater to cool, disassemble the heater, and then move the heater inside the tent.

Make sure you allow enough air space between the tent walls and the heater unit, at least 4 feet (1.22 m). While in operation, the heater exterior will become very hot. Frequently check for heating of the tent walls while the heater unit is in use. If the tent walls become too hot, the heater needs to be shutdown, allowed to cool, and moved to a tent stack shield opening location farther away from the tent walls, if available, or the amount of solid fuel used in the heater needs to be decreased. Failure to follow these procedures could result in the heater igniting the tent.

NOTE

For best operation, be sure that the heater is as level as possible.

1. To prepare the H-45 Type II (Liquid Fuel) Heater for operation (after the protective film has been burned off), place the heater on the ground under a tent stack shield opening. If used on top of a tent floor, the heater must be set on a bed of sand or placed on three or four bricks. Level the base by eye.

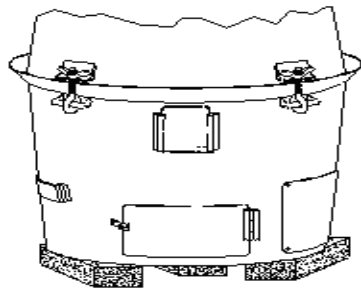

BRICKS

LEVELING THE H-45

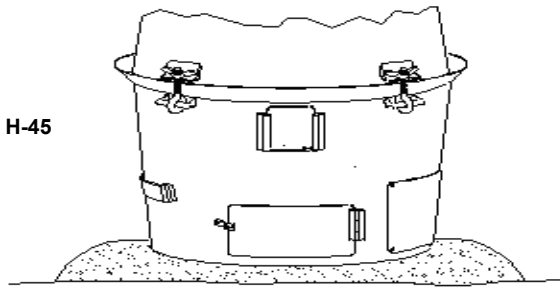

SAND

2. Open the front base heater door (1), pull the priming cup (2) on the retainer wire (3) out of the heater body base until the wire is fully extended, and set aside.
3. Remove the top heater shell (4) from the heater body base (8) by loosening the wing nuts on the bolt and wing nut assemblies (21) and sliding them out of the brackets (22) on the top heater shell (4). Set the top heater shell (4) aside. If not already done, remove all the components stored inside the heater. (See WP 0009 00 for an inventory of all the components.)
4. Replace the burner shell assembly (5) in the heater body base (8). If necessary, rotate the burner shell assembly (5) to ensure that the pipe nipple (6) aligns with the left side of the front base heater door opening (7) in the heater body base (8). Pull the flow control burner hose (9) through the front base heater door opening (7). The burner shell assembly (5) and adapter ring (10) welded to its top must be level and fully engaged all around the circumference of the heater body base (8).
5. The superheater (11), burner cap assembly (12), and high fire ring (13) are all installed when shipped. Ensure that these parts are in place as illustrated.
6. Insert the fuel flow control valve (14) into the bracket holder (15) on the heater body base (8).
7. Attach the free end of the flow control burner hose (9) to the flow control outlet (16) on the bottom of the fuel flow control valve (14). To do this, pull back on the female QD fitting on the end of the flow control burner hose (9), insert it on the flow control outlet male QD fitting, and release the female QD fitting. Gently pull on the flow control burner hose to ensure the connection is secure.
8. Attach the female QD fitting on the fuel overflow hose (17) to the fuel overflow male QD fitting (18) on the fuel flow control valve (14). To do this, pull back on the female QD fitting on the fuel overflow hose (17), insert it on the fuel overflow male QD fitting (18) on the fuel flow control valve (14), and release the female QD fitting. Gently pull on the fuel overflow hose to ensure the connection is secure. Set the free end of the fuel overflow hose aside.
9. Connect the female QD fitting (19) on the fuel supply hose (23) to the fuel supply male QD fitting (20) on the fuel flow control valve (14). To do this, pull back on the female QD fitting (19) on the end of the fuel supply hose (23), insert it on the fuel inlet male QD fitting (20), and release the female QD fitting (19). Gently pull on the fuel supply hose (23) to ensure the connection is secure. Set the free end of the fuel supply hose (23) aside.

10. Place the top heater shell (4) on the heater body base (8). Place the bolt and wing nut assemblies (21) in the brackets (22) on the top heater shell (4) and tighten the wing nuts.

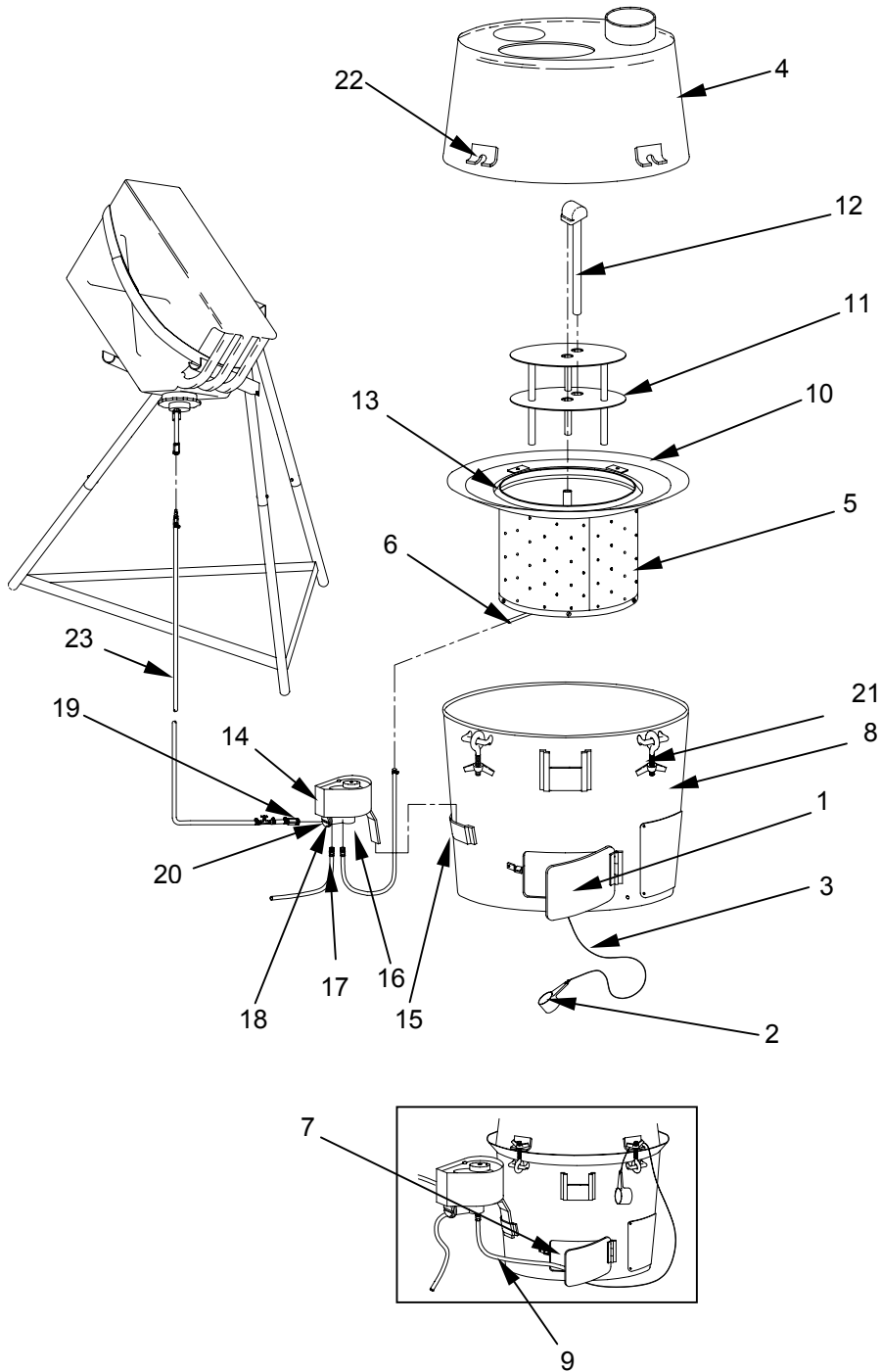

PREPARING THE TYPE II (LIQUID FUEL) HEATER FOR OPERATION

Assembling The Stack For H-45 Type II (Liquid Fuel) Heater Operation**WARNING**

Ensure the stack pipe sections seat together securely. Poorly fitted stack sections may allow a hot stack to fall on the tent and start a fire or allow deadly carbon monoxide to leak into the tent.

It is important to stake the exhaust stack securely since this will keep the exhaust stack vertical and seated firmly within the stack adapter with a downward force. This also stabilizes the heater and helps prevent it from being knocked over if bumped by equipment or people inside the tent.

The tent needs to be securely staked to prevent the tent roof and walls from flapping during snowy and windy conditions. If the tent itself is not tightly staked, the roof and sidewalls can flap, getting close to the heater and creating a fire danger. (Refer to the tent-specific operator manual on the proper staking of the tent.)

During operation, the H-45 heater produces harmful carbon monoxide and other gases. Carbon monoxide is a colorless, odorless, and tasteless gas. Remember that although carbon monoxide has no telltale odor, it may mix with other odors that mask its presence; therefore, carbon monoxide can be present within a mix of seemingly harmless odors. Mild cases of carbon monoxide poisoning can cause symptoms such as nausea, dizziness, or headaches. Severe cases of carbon monoxide poisoning can result in brain damage, heart damage, or death.

To prevent carbon monoxide poisoning, ensure that the H-45 heater exhaust stack sections fit together snugly and that the exhaust gases are properly vented through the roof of the tent. Keep the H-45 heater in good working order. Ensure that all possible sources of carbon monoxide leakage have been repaired and that the operating space is well ventilated.

NOTE

All six stack pipe sections and stack cap assembly must be assembled, put securely in place on the top heater shell flange, and tied down during heater operation. Failure to use all six sections will adversely affect heater performance, increase soot buildup, and increase maintenance.

The type of tent, use of a step aid (if available), and height and strength of the persons assembling the stack may alter the following stack assembly procedures.

1. When the H-45 Type II (Liquid Fuel) Heater is first delivered, the stack assembly sections are provided as curved sheet metal sections. They must be formed into cylinders and their seams locked. Refer to the section entitled "Assembling the Stack Sections for the H-45 Type II (Liquid Fuel) Heater" in WP 0009 00 for information on assembling the sections before initial use.
2. Outside the tent, roll back the flap **(12)** on the tent stack shield opening **(11)**, and tie it back securely. (Refer to the tent-specific operator manual for this procedure.)
3. Inside the tent, securely install the uncrimped end of one of the stack sections onto the crimped end of another stack section **(8-3)**. Securely install the stack cap assembly **(1)** with the attached guy lines **(2)** onto the crimped end of the stack section **(3)**.
4. Insert the stack cap and attached guy lines through the tent stack shield opening.
5. Securely install the bottom of the stack assembly **(8)** onto the flange **(9)** on the top heater shell.
6. One person should remain in the tent stabilizing the stack assembly, while two other persons go outside the tent and retrieve the three guy lines **(2)** from the roof of the tent.

NOTE

The use of a long stick or other such object (not supplied with the H-45) may be needed to retrieve the guy lines from the tent roof. Once the guy lines are retrieved, additional lengths of rope (not supplied with the H-45) may have to be added to the end of each guy line before the ropes can be anchored to the stakes.

7. Outside the tent, drive three stakes (not supplied with the H-45) into the ground, positioned evenly apart and a minimum of 2 feet (0.61 m) from the base of the tent. Space the guy lines **(2)** equally to ensure the stack is in a vertical and stable position. Securely anchor the guy lines **(2)** to the stakes ensuring that the lines are stretched tight. Ensure the guy lines and ropes DO NOT touch the roof or sides of the tent.

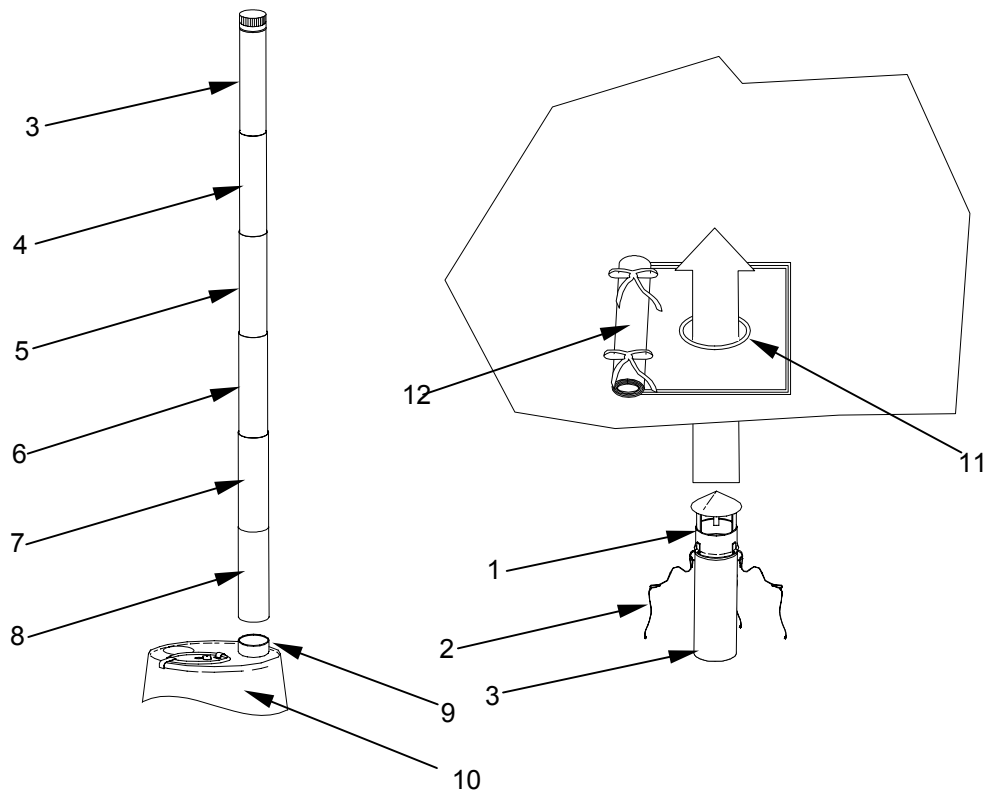

ASSEMBLING THE STACK FOR H-45 TYPE II (LIQUID FUEL) HEATER OPERATION

Preparing A Fuel Supply Site For The H-45 Type II (Liquid Fuel) Heater Operation

1. Select a level fuel supply site, free of debris and open flame, at least 7 feet (2.13 m) from the tent.
2. From the inside of the tent, route the free ends of the fuel supply hose and the overflow hose (set aside in the earlier section "Preparing The Type II (Liquid Fuel) Heater For Operation") outside of the tent under the tent wall. The fuel supply hose should be routed to the fuel supply location and the overflow hose should discharge to a safe, downward-sloping, outside location below the level of the fuel flow control valve. Place a petroleum absorbent mat under the open end of the overflow hose.

NOTE

A piece of commercial petroleum absorbent material should be placed under the open end of the overflow hose to catch any fuel that may spill. Additional commercial products are available to contain large spills.

Installing The Gravity Feed Adapter On The Fuel Can

WARNING



The H-45 Type II (Liquid Fuel) Heater incorporates a burner that vaporizes liquid fuel, which enhances combustion efficiency and prevents flooding. It is designed to operate with the following fuels in the order listed: JP-8; DF-A, DF-1, or DF-2; JP-5; kerosene; Jet A-1; Jet A; gasoline (**emergency only**); JP-4 (**emergency only**).

Used motor oil, solvents, and other unauthorized fuels should **NOT** be used with the H-45 under any circumstance. **Only approved liquid and solid fuels may be used. Gasoline and JP-4 should be used only in emergency situations when there is no other fuel available and when the soldier's health and unit readiness are in jeopardy.** Using gasoline, JP-4, or unauthorized fuels in the H-45 will create a fire danger and potential for explosion.

WARNING



The gravity feed adapter must be tightened securely to prevent fuel leakage and fire.

1. Inside the tent, set the fuel OFF/ON control **(1)** on the fuel flow control valve **(2)** on the H-45 Type II (Liquid Fuel) Heater to the OFF position. Also ensure that the priming valve T-connector **(10)** on the fuel supply hose **(8)** that is inside of the tent is in the closed position (turn clockwise to tighten).

NOTE

A piece of commercial petroleum absorbent material should be used to catch any fuel that may spill while connecting or disconnecting any hoses. Additional commercial products are available to contain large spills.

In the event that fuel is spilled on the ground, immediate action must be taken to contain the spill, and the appropriate environmental personnel should be notified.

Clean up any spilled fuel with a rag. Dispose of the rag and/or absorbent material in accordance with the local Material Safety Data Sheet (MSDS) procedure.

2. Outside the tent, remove the attached fuel cap (3) from the mouth (4) of the fuel can (5), and replace it with the gravity feeder adapter (6). Screw the adapter onto the fuel can securely.
3. While the fuel can is still upright, attach the fuel supply hose (8) to the gravity feed adapter (6). To do this, pull back on the gravity feed adapter female QD fitting (9), insert the fuel supply hose male QD fitting (7) into the gravity feed adapter female QD fitting (9), and release the female QD fitting (9). Gently pull on the fuel supply hose (8) to ensure the connection is secure. Set the assembled fuel can aside in the upright position.
4. At the fuel supply site, set up the fuel can stand with the fuel can (5) level with or slightly above the heater as detailed in the next section of this work package.

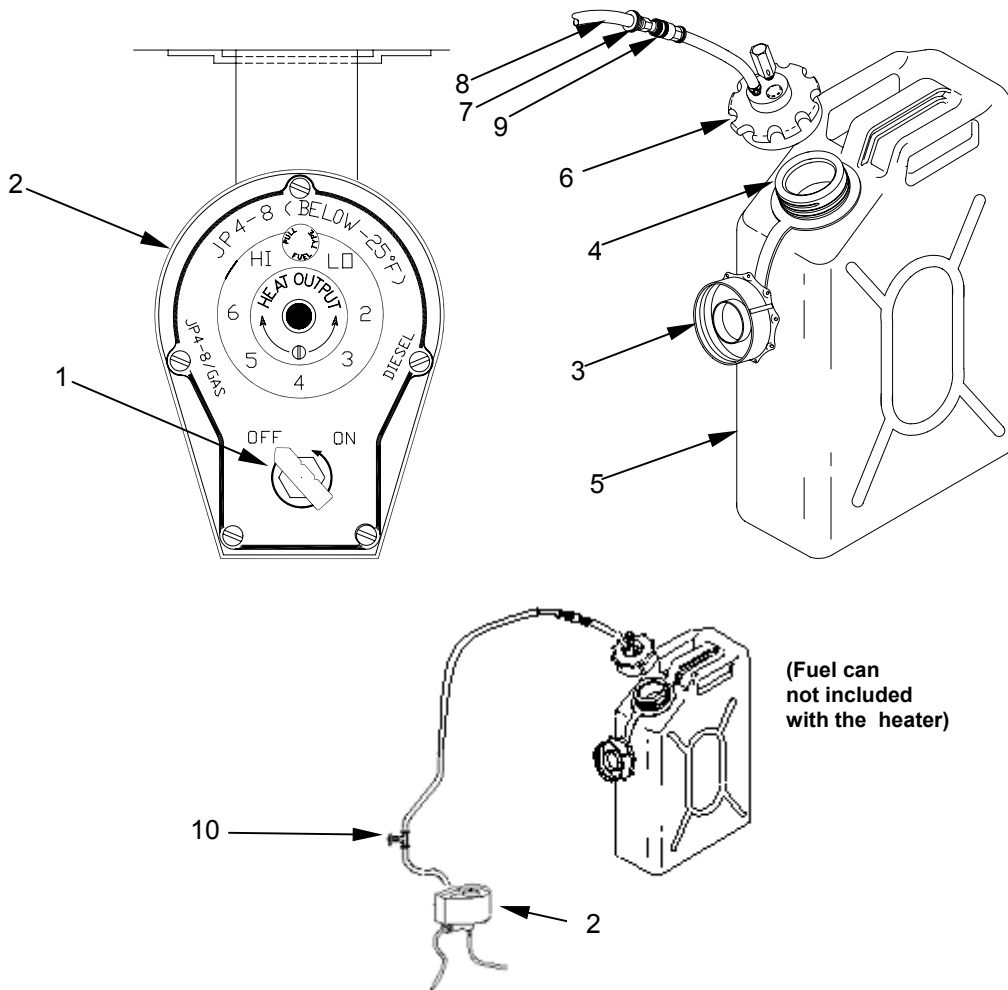

INSTALLING THE GRAVITY FEED ADAPTER ON THE FUEL CAN

Setting Up The Fuel Can Stand

When using liquid fuel, the fuel can stand must be assembled in order to mount the fuel can in the proper position. The fuel can, outfitted with a fuel can gravity feed adapter, must be mounted to the stand with the gravity feed adapter facing down.

1. Insert the bottom leg assembly (1) into the top leg assembly (2) until each leg is locked in place. Be sure to orient each bottom leg so that the stabilizing straps (3) are positioned toward the inside of the stand. Ensure that the straps are not twisted.

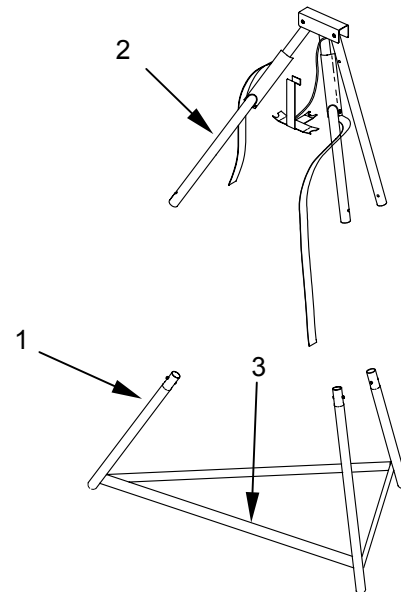

2. Spread the assembled leg assembly (4) until the stabilizing straps (3) are fully extended and the stand is stable. The stabilizing straps (3) are designed to ensure the stand is stable and are also designed to prevent the stand from sinking into snow and mud.

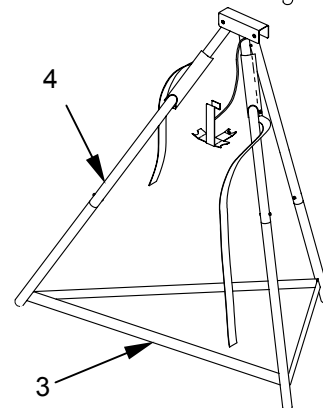

3. Lower the left (5) and right (6) support arms so that each is at a right angle to its attached leg. Place the tripod brace (7) under the top bracket (8) of the stand and clip into position over the front of the top bracket.

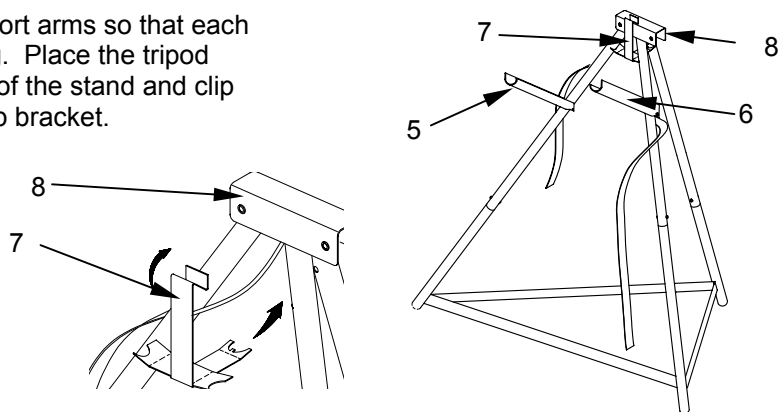

NOTE

Make sure that the fuel can gravity feed adapter is fully seated and secured to avoid leaking.

- Invert the fuel can (9) with the installed gravity feed adapter (10) and mount on the assembled fuel can stand so that the gravity feed adapter (10) faces the ground. Slide the fuel can handle (11) over the right support arm (8) and allow the inverted fuel can to rest on the right and left support arms (8,14). Wrap the left support strap (12) over the bottom of the fuel can (9). Feed the right support strap (13) through the fuel can handle (11), up across the front of the fuel can body, and over the left support strap (12). Secure the right strap (13) to the left strap (12) using the hook and pile fastening.

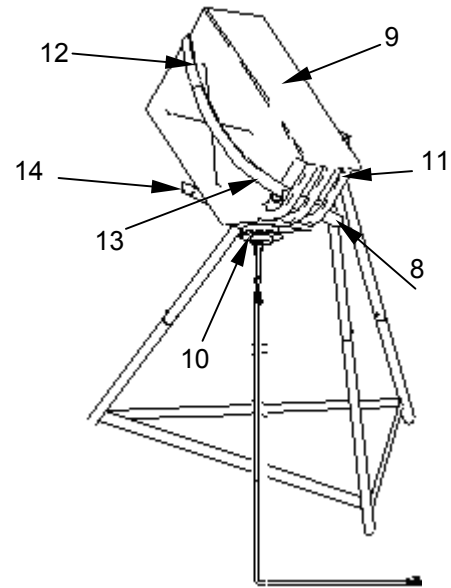
**NOTE**

The strap is needed to secure a partially filled fuel can to the fuel stand during windy conditions.

NOTE

If a fuel can stand is unavailable, invert the fuel can with the installed gravity feed adapter on a stable support so that the opening of the fuel can at the fuel site is 2 feet (60.96 cm) to 3 feet (91.44 cm) higher than the height of the fuel flow control valve.

Starting The H-45 Type II (Liquid Fuel) Heater**NOTE**

For best operation, be sure that the heater is as level as possible.

Inspect the burner, and drain any water that has collected on the bottom of the burner assembly due to rain, snow, or moisture before lighting the heater.

General.

- If the fuel type is **NOT** known, refer to the section later in this work package entitled "Starting The H-45 Type II (Liquid Fuel) Heater When The Fuel Type Is **NOT** Known."
- If the fuel type **IS** known, refer to the following section entitled "Starting The H-45 Type II (Liquid Fuel) Heater When The Fuel Type **IS** Known."

Starting the H-45 Type II (Liquid Fuel) Heater when the fuel type IS known.

1. Open both base heater doors (1,2).
2. Set the fuel selector control knob (6) to the proper position for the ambient temperature and the fuel being used as described in WP 0004 00, Table 2. Once the temperature and fuel are determined, lift the fuel selector control knob (6), and turn the entire control assembly until the fuel selector control knob (6) engages in the detent. Release the fuel selector control knob (6).
3. Turn the fuel OFF/ON control (7) on the fuel flow control valve (8) to the ON position.

NOTE

The flow adjustment knob (9) on top of the fuel flow control valve increases the fuel flow when turned clockwise and decreases the fuel flow when turned counterclockwise.

4. Turn the flow adjustment knob (9) to the HI position. Wait 5 to 10 minutes for the flow control burner hose (11) and burner uptube (10) to fill with fuel. Shake and tap the hoses (11,15) to free any air that may be trapped in the hoses. Turn the flow adjustment knob (9) back to setting "3."
5. Using the 4-ounce cup (12) attached to the retaining wire (13), open the priming valve T-connector (14) on the fuel supply hose (15), and carefully fill the cup with fuel. Remove the lid assembly (18), and pour one 4-ounce cup of fuel into the bottom of the burner shell assembly (16) through the lid assembly opening.

NOTE

When operating with diesel fuel or JP8 in very cold temperatures, if problems are experienced getting the heater to light or to continue burning, it may be necessary to repeat step 5. Make sure the flame is out completely and the heater is cool before adding additional fuel. NEVER add additional fuel when the burner is lit or hot. This procedure should NOT be used with gasoline or JP4.

6. Roll a piece of tissue paper, or similar material, into a ball approximately 2 inches in diameter. Use the paper to wipe the cup (12) to remove any remaining fuel. Do not discard the paper. It will be used when lighting the heater as follows:

WARNING



Keep your hands and face away from heater lid opening when lighting the burner to prevent getting burned.

If the flame is accidentally extinguished, WAIT UNTIL THE BURNER COOLS BEFORE RELIGHTING. NEVER LIGHT A HOT HEATER. LIGHTING A HEATER THAT HAS NOT COOLED COULD RESULT IN AN EXPLOSION.

NOTE

Check all three hoses, the fuel flow control valve, and the gravity feed adapter for leaks before and after lighting the heater. Make sure that all QD fittings are securely engaged. If a leak occurs while the heater is in operation, shut down the heater immediately, and notify your supervisor if the leak cannot be corrected.

When operating with gasoline or JP 4 (**emergency use only**), light as soon as possible after pouring one 4-ounce cup of fuel in the burner. Throw in a lit match and stand back immediately.

Lighting the burner when gasoline or JP-4 fuel (emergency use only) is used.

1. When lighting the burner with gasoline or JP-4 fuel, keep your hands and face away from the heater lid opening to prevent getting burned. Drop the tissue paper used to wipe the cup (12) into the burner shell assembly (16) before lighting the burner. Then drop a lighted match into the burner shell assembly (16) through the heater lid opening, and immediately stand back.
2. Once the heater is lit, replace the heater lid.

Lighting the burner when JP-8, diesel, JP-5, kerosene, Jet A-1, or Jet A fuel is used.

1. When lighting the burner with JP-8, diesel, JP-5, kerosene, Jet A-1, or Jet A fuel, place the tissue paper used to wipe the cup (12) on the top of the heater near the edge of the heater lid opening. Light the tissue paper, and push the paper into the burner shell assembly, making sure it goes to the bottom of the burner shell assembly (16). The burner reaming tool (17) can be used to force the burning paper to the bottom of the burner shell assembly (16) if necessary.
2. Replace the heater lid immediately.

NOTE

If fuel flow is slow, shake and/or tap the hoses to eliminate any air bubbles.

3. With the fuel flow adjustment knob at setting "3," wait until the burner shell assembly warms up before increasing the fuel flow with the fuel flow adjustment knob.

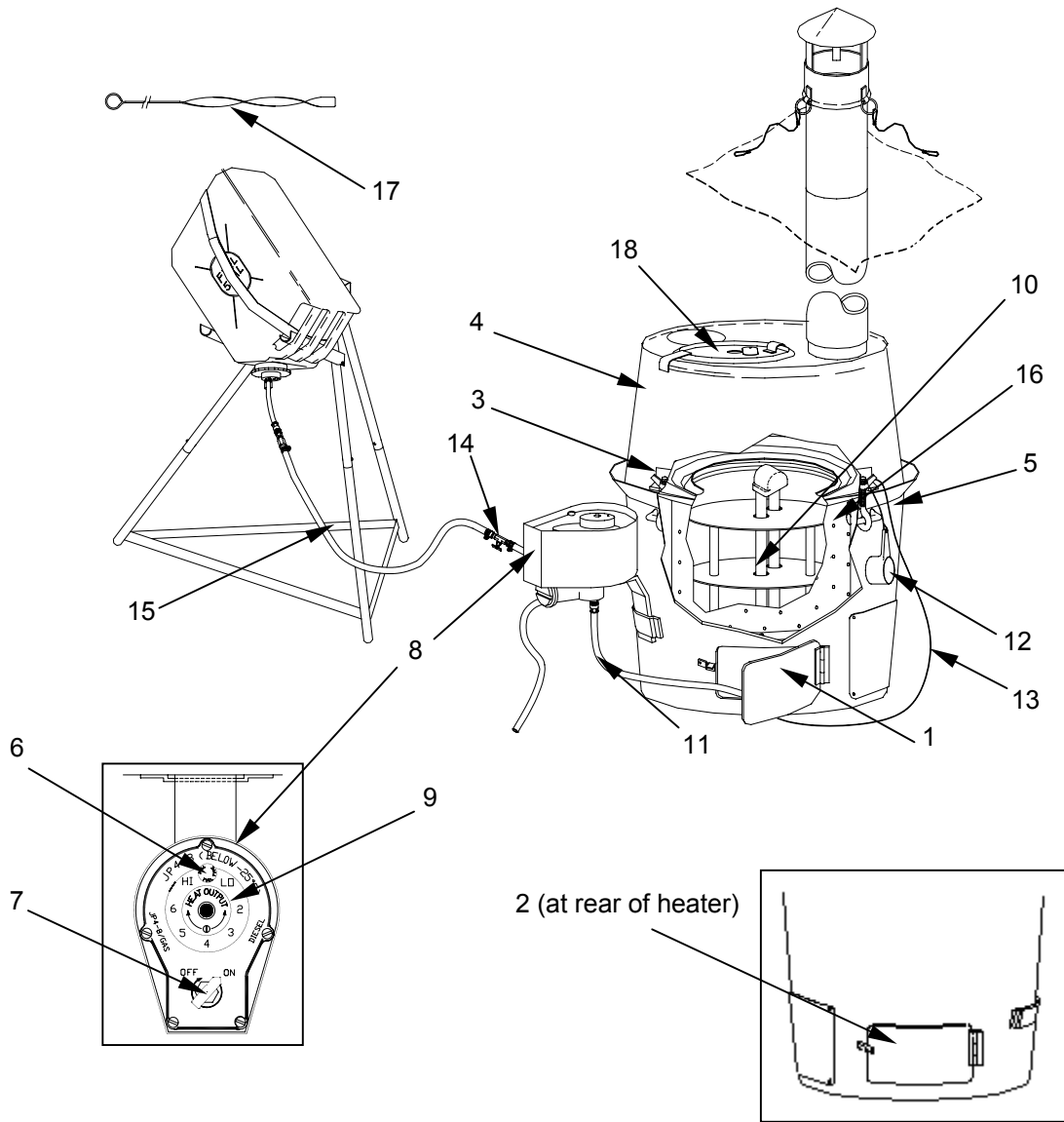

STARTING THE H-45 TYPE II (LIQUID FUEL) HEATER WHEN THE FUEL IS KNOWN

Starting the H-45 Type II (Liquid Fuel) Heater when the fuel type is NOT known.

1. If starting the heater when the fuel is **NOT** known, it should be assumed for safety reasons that the fuel is gasoline. The heater should, therefore, be started using the gasoline starting method.
2. To start the Type II (Liquid Fuel) heater when the fuel type is unknown, set the fuel selector control knob **(1)** in the JP4-8/ GAS position **(2)** by lifting the fuel selector control knob **(1)** and turning the entire control assembly until the fuel selector control knob **(1)** is set to the JP4-8/GAS position **(2)**. Release the fuel selector control knob **(1)** and make sure that the fuel selector control knob **(1)** engages in the locking detent.
3. Start the heater as described in the previous section entitled "Starting the H-45 Type II (Liquid Fuel) Heater When The Fuel Type IS Known," and operate for 10 to 15 minutes. If the fire is burning low and not generating much heat, set the fuel selector knob **(1)** to the DIESEL position **(3)**.

NOTE

When operating with gasoline, light the heater as soon as possible after pouring the cup of fuel in the burner. Throw in a lit match, and stand back immediately.

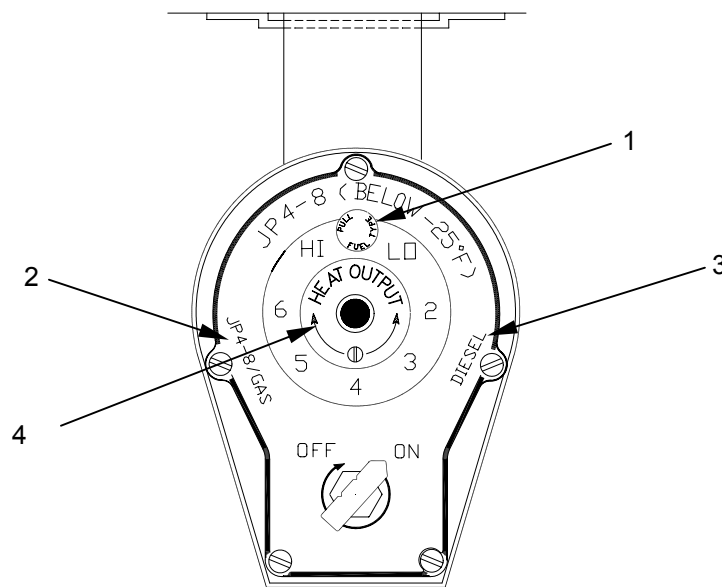

STARTING THE TYPE II (LIQUID FUEL) HEATER WHEN THE FUEL TYPE IS NOT KNOWN

General Operating Characteristics Of The H-45 Type II (Liquid Fuel Heater)**NOTE**

The heater is designed to operate at various firing rates, producing between 20,000 to 45,000 BTUs. A smoking, pulsing, or sooty heater indicates an overfire or underfire condition.

Viscosity of liquid fuel is not consistent at all times and locations. If the heater appears to be overfiring at high settings or underfiring at low settings, adjust the fuel flow adjustment knob **(4)** counterclockwise or clockwise until the flame is clear, no smoke or soot is observed, and the pulsing stops.

Refueling The H-45 Type II (Liquid Fuel) Heater

WARNING



Do not attempt to refuel a hot space heater. Allow the flame to go out and the heater to cool completely before handling or refueling.

1. Set the fuel OFF/ON control **(1)** on the fuel flow control valve to OFF to shut down the heater.

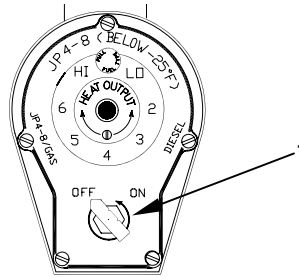

2. At the fuel supply site, remove the empty fuel can **(2)** from the fuel can stand **(3)**. To do this, unstrap the fuel can by pulling back on the right support strap **(9)** that is connected by the hook and piling fastener to the left support strap **(10)**. Slide the right support strap **(9)** through the fuel can handle **(11)**. Slide the fuel can off the right and left support arms **(12,13)** of the fuel can stand **(3)**. Place the empty fuel can **(2)** upright on the ground.

NOTE

Place absorbent material under the fuel supply hose connections before replacing the empty fuel can with a full fuel can.

When replacing the empty fuel can with a full fuel can, make sure the male QD fitting on the fuel supply hose remains higher than the fuel flow control valve so that any fuel remaining in the fuel supply hose does not leak out.

3. Remove the fuel supply hose **(4)** from the gravity feed adapter **(5)**. To do this, pull back on the female QD fitting **(6)** on the end of the gravity feed adapter **(5)**, and remove the fuel supply hose male QD fitting **(7)**. Unscrew and remove the gravity feed adapter **(5)** from the fuel can **(2)**, and set aside. Screw the fuel can cap **(8)** on the empty fuel can **(2)**, and stow the empty fuel can in an authorized location.

NOTE

Before replacing the empty fuel can with a full fuel can, make sure the fuel in the full fuel can is the same fuel that was in the empty fuel can.

Once the type of fuel is determined, ensure the H-45 Type II (Liquid Fuel) Heater fuel control setting is set for the fuel being used as detailed earlier in this work package: "Starting The Type II (Liquid Fuel) Heater."

Because the empty and full fuel cans should be the same type of fuel can, the numbers in the following figure used for the empty fuel can are also used for the full fuel can.

4. Unscrew the fuel can cap **(8)** on the full fuel can, and install the fuel can gravity feed adapter **(5)** on the full fuel can. Reattach the fuel supply hose **(4)**. Then, install the full fuel can on the fuel can stand **(3)** as follows:

NOTE

Make sure that the fuel can gravity feed adapter is fully seated and secured to avoid leaking.

5. Invert the full fuel can **(2)** with the installed gravity feed adapter **(5)**, and mount the inverted fuel can **(2)** on the assembled fuel can stand **(3)** so that the gravity feed adapter **(5)** faces the ground. Slide the fuel can handle **(11)** over the right support arm **(12)** and allow the inverted fuel can to rest on the right and left support arms **(12,13)**. Wrap the left support strap **(10)** over the bottom of the fuel can **(2)**. Feed the right support strap **(9)** through the fuel can handle **(11)**, up across the front of the fuel can body, and over the left support strap **(10)**. Secure the right strap **(9)** to the left strap **(10)** using the hook and pile fastening.

NOTE

The strap is needed to secure a partially filled fuel can to the fuel stand during windy conditions.

6. Restart the heater as described earlier in this work package: "Starting The Type II (Liquid Fuel) Heater."

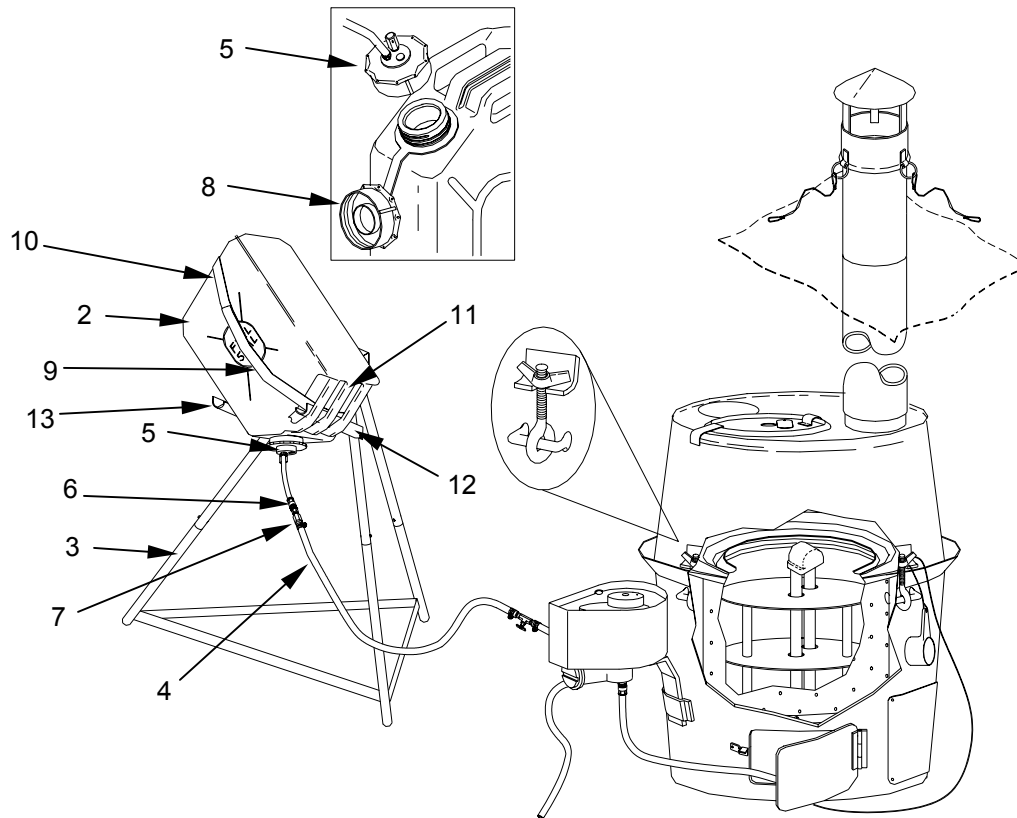

REFUELING THE TYPE II (LIQUID FUEL) HEATER

Shutting Down The H-45 Type II (Liquid Fuel) Heater

1. To stop heater operation turn the fuel OFF/ON control (1) to the OFF position.

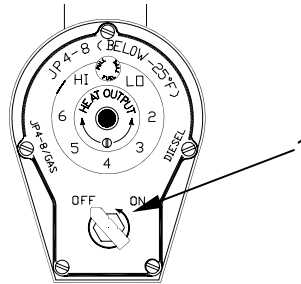

2. Outside the tent, at the fuel supply site, unstrap the fuel can from the fuel can stand, remove the fuel can from the fuel can stand, and place the fuel can upright on the ground. Remove the gravity feed adapter, and screw on the gas can lid. To do this, see the previous section in this work package entitled "Refueling The Type II (Liquid Fuel) Heater," steps 1-3.

Preparing The H-45 Type II (Liquid Fuel) Heater For Movement

WARNING



Do not attempt to disassemble a hot heater unit. Severe burns may result.

WARNING



The H-45 Type II (Liquid Fuel) Heater with the shipping container, weighs approximately 75 pounds (34.06 kg). Two persons must carry the H-45 Type II (Liquid Fuel) Heater, lifting using their legs, not their backs, to prevent injury.

1. Shutdown the H-45 Type II (Liquid Fuel) Heater as described earlier in this work package: "Shutting Down The H-45 Type II (Liquid Fuel) Heater." Let the heater cool completely.
2. Outside the tent, remove the guy lines (13) from the stakes. Stow the three stakes that were used to anchor the guy lines. (Refer to the tent-specific operator manual for stowing the stakes.)

3. Inside the tent, lift the stack assembly **(14)** from the stack flange **(15)** on the top heater shell **(19)**. Lower the stack cap **(16)** with attached guy lines **(13)** through the tent stack shield opening **(17)**. Lay the stack assembly **(14)** on the tent floor.
4. Remove the stack cap **(16)** with attached guy lines **(13)** from the topmost stack section. Stuff the guy lines **(13)** inside the stack cap **(16)**, and set it aside for storage inside the heater. Separate the six stack sections, leaving the seams of the stack pipe sections sealed, and set them aside for storage or transport. Close the flap on the tent stack shield opening **(17)**. (Refer to the tent-specific operator manual for closing the tent stack shield.)
5. Outside the tent, at the fuel supply site, unstrap the fuel can **(1)** from the fuel can stand **(2)**, remove the fuel can **(1)** from the fuel can stand **(2)**, and place the fuel can **(1)** upright on the ground. To do this, see the previous section in this work package entitled "Refueling The Type II (Liquid Fuel) Heater," steps 1 and 2.

NOTE

A piece of commercial petroleum absorbent material should be used to catch any fuel that may spill while connecting or disconnecting any hoses. Additional commercial products are available to contain large spills.

In the event that fuel is spilled on the ground, immediate action must be taken to contain the spill, and the appropriate environmental personnel should be notified.

Clean up any spilled fuel with a rag. Dispose of the rag and/or absorbent material in accordance with the local Material Safety Data Sheet (MSDS) procedure.

6. Inside the tent, place a piece of commercial petroleum absorbent material under the end of the fuel supply hose **(3)** that connects to the fuel flow control valve **(4)**. Disconnect the fuel supply hose **(3)** from the fuel flow control valve **(4)**. To do this, pull back on the female QD fitting on the end of the fuel supply hose **(3)**, and remove it from the male QD fitting on the fuel flow control valve **(4)**.
7. Disconnect the fuel overflow hose **(11)** from the fuel flow control valve **(4)**. To do this, pull back on the female QD fitting on the end of the fuel overflow hose **(11)**, and remove it from the male QD fitting on the fuel flow control valve **(4)**.
8. Outside the tent, pull the fuel overflow hose **(11)** from under the tent wall, coil it, and set it aside for storage inside the heater.
9. Outside the tent, pull the fuel supply hose **(3)** from under the tent wall. Drain any fuel remaining in the fuel supply hose **(3)** by coiling the hose from the heater to the gravity feed adapter **(5)** while holding the hose above the level of the fuel can **(1)**. To do this, open the priming valve T-connector **(6)** slightly to allow air to enter the hose and to allow the fuel to drain completely back into the fuel can.

10. Disconnect the male QD fitting of the fuel supply hose (3) from the gravity feed adapter (5). To do this, pull back on the female QD fitting on the gravity feed adapter (5), and remove the male QD fitting on the fuel supply hose (3). Connect the two ends of the fuel supply hose (3) in order to prevent debris from entering the connectors. To do this, pull back on the female QD fitting end of the fuel supply hose, insert the male QD fitting end of the fuel supply hose (3) into the female QD fitting, and release the female QD fitting. Pull gently on the ends of the hose to ensure the connection is secure. Set the fuel supply hose (3) aside for storage inside the heater body base (9).
11. Unscrew and remove the gravity feed adapter (5) from the fuel can (1). Set the gravity feed adapter (5) aside for storage inside the heater body base (9). Screw the fuel can cap (7) on the fuel can (1). Stow the fuel can (1) in an authorized location.
12. Disassemble the fuel can stand (2) in the reverse order of the assembly procedures for the fuel can stand (2) described previously in this work package, and set aside for storage inside the heater body base (9).
13. Inside the tent, disconnect the flow control burner hose (8) from the base of the fuel flow control valve (4). Return the flow control burner hose (8) to its storage location inside the heater body base (9). Insert the measuring cup (22) with cable (23) inside the heater body base (9). Close and lock the front and rear base heater doors (10).
14. Remove the fuel flow control valve (4) from the bracket holder (12) on the side of the heater body base (9).
15. Tip the fuel flow control valve (4) over the commercial petroleum absorbent material, and shake it so that all fuel exits the valve. Set the fuel flow control valve (4) aside for storage inside the heater. Dispose of the commercial petroleum absorbent material in accordance with the local Material Safety Data Sheet (MSDS) procedure.
16. Loosen the three wing nuts on the bolt and wing nut assemblies (18) holding the top heater shell (19) to the heater body base (9), remove the bolt and wing nut assemblies (18) from the brackets (24), and remove the top heater shell (19).
17. Remove the burner shell assembly (20) from the heater body base (9).
18. Clean all components of soot, carbon buildup, and fuel residue with a brush and/or rag.
19. Place the burner shell assembly (20) with attached flow control burner hose (8) in the heater body base (9).
20. Coil the hoses (3, 11) and place them on the lip of the heater body base (9). Place the fuel flow control valve (4), stack cap with guy lines (16,13), gravity feed adapter (5), lid assembly (21), burner reaming tool (25), and fuel can stand (2) in the heater body base (9).
21. Place the top heater shell (19) on the heater body base (9). Place the bolt and wing nut assemblies (18) in the brackets (24) on the top heater shell (19), and tighten the wing nuts.

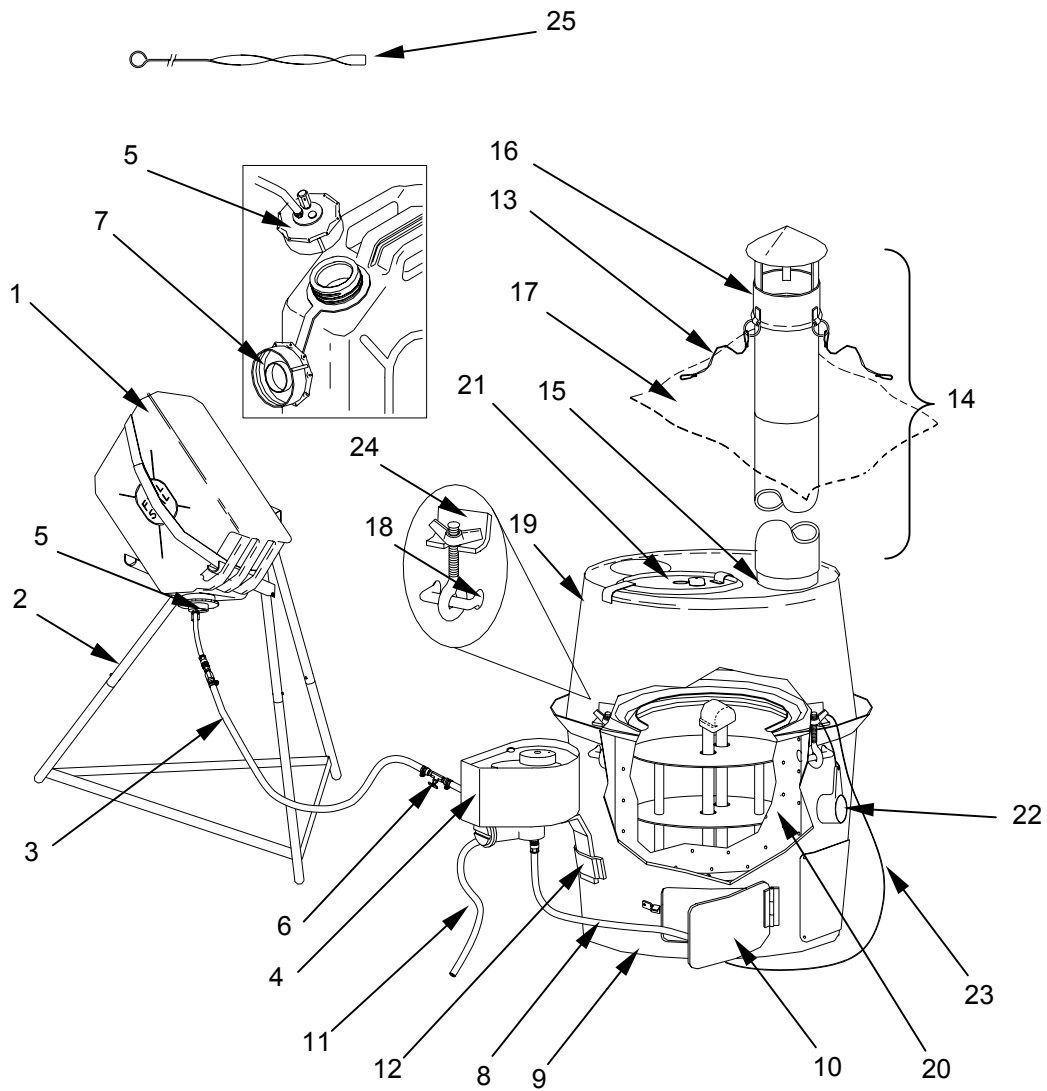

PREPARING THE H-45 TYPE II (LIQUID FUEL) HEATER FOR MOVEMENT

Lubrication Requirements For The H-45 Type II (Liquid Fuel) Heater.

The door hinge, door latch assembly, bolt and wing nut assemblies, and sight glass cover on the heater lid should be lubricated with a light machine oil before storing the heater.

OPERATING THE THERMOELECTRIC FAN (TEF)
(optional item, refer To AAL, WP 0051 00)**WARNING**

The base plate of the TEF gets very hot during operation. Take care in handling the fan to avoid burns or other serious injury. If it is necessary to remove the TEF from the lid assembly while the heater is in operation, be sure to place the TEF on a surface that will not melt or burn.

CAUTION

Do not block the flow of air out of the fan by placing gloves or other articles on the grill of the fan.

General

The TEF **(1)** helps to circulate the heat generated by the H-45 heaters **(2)** throughout the tent. The TEF is self-powered and generates its own power directly from the heat radiated by the H-45 heaters. As the TEF base plate **(5)** heats up, that heat is converted into electrical energy to operate the TEF. The TEF is an optional piece of equipment and is listed in the Additional Authorization List (WP 0051 00).

Unpacking

To unpack the TEF from its storage container **(3)** unscrew and remove the storage container cover. Grasp the TEF by the handle **(4)** mounted on the grill, and lift the TEF **(1)** out of the container.

Operating

To operate the TEF, place the base plate **(5)** of the TEF in the recess **(6)** to the left of the heater lid **(7)** on the top of the heater **(2)**. Within 5-10 minutes, the TEF will reach full operating capacity.

Repacking

To repack the TEF **(1)**, allow it to cool completely, pick it up by its top handle **(4)**, and lower it into the storage container **(3)**. Place the storage container cover on the top of the storage container **(3)** and screw it securely into place.

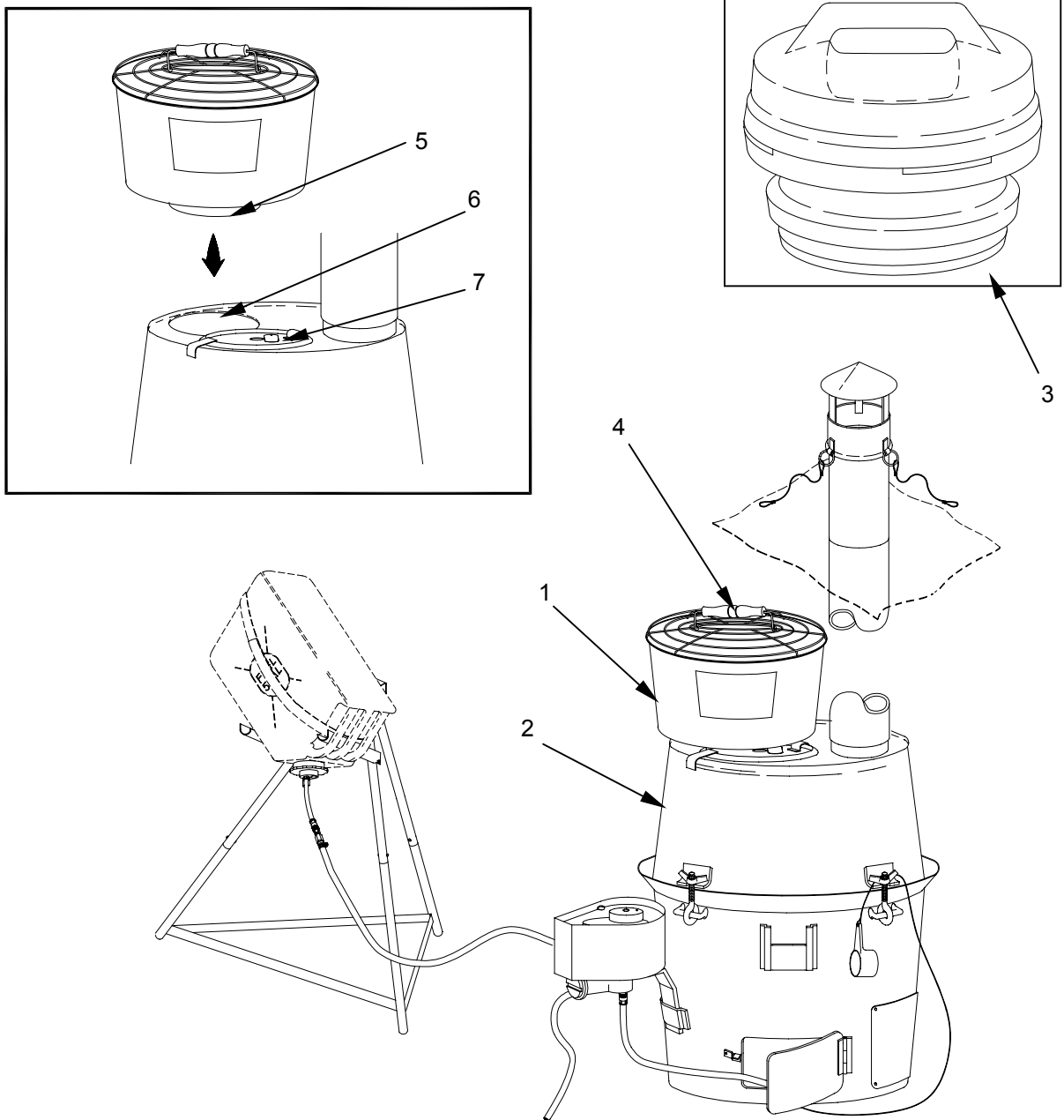

END OF WORK PACKAGE

THIS PAGE INTENTIONALLY LEFT BLANK

**OPERATOR AND UNIT MAINTENANCE
H-45 LARGE RADIANT SPACE HEATER
(TYPE I, SOLID FUEL)
NSN 4520-01-354-1191
(TYPE II, LIQUID FUEL)
NSN 4520-01-329-3451
OPERATION UNDER UNUSUAL CONDITIONS**

OPERATION IN UNUSUAL ENVIRONMENT AND/OR WEATHER CONDITIONS

General

Refer to Operation Under Usual Conditions (WP 0005 00), for specific operating instructions, and use this work package for further instruction if operating the heater in unusual conditions. Read all sections that apply to the conditions to which your heater will be exposed.

OPERATION IN DUSTY OR SANDY CONDITIONS

Liquid Fuel Operation Only

Inspect fuel line ends and fuel flow control fittings before making connections to ensure they are not contaminated with dust or sand.

Keep lids installed on all fuel cans.

OPERATION IN EXTREME COLD CONDITIONS

WARNING

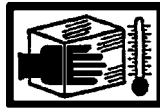

Severe injury may occur to personnel handling metal parts without protective gloves when temperatures are below freezing. Skin may freeze upon contact and tear from the flesh.

NOTE

When the temperature is below -25° Fahrenheit (-31.67° Celsius) and JP4-8 fuel is used, be sure the fuel selector control is placed in the JP4-8 (BELOW -25° F) position.

Do not overfuel the H-45 Type I (Solid Fuel) Heater. When using coal in the H-45 Type I (Solid Fuel) Heater, remember that coal is a very dense fuel and generates significant heat output even when a small quantity is used. Using a large quantity of coal may overfire the heater, making its output difficult to control. Overfueling the heater may also cause overheating of the stack assembly resulting in igniting the tent fabric.

Do not place the H-45 Type I (Solid Fuel) Heater directly on snow, as the heater will quickly melt the snow and extinguish the fire. Place the heater on a bed of bricks, a sandbox, or a tray during use.

Whether using the H-45 Type I (Solid Fuel) Heater or the H-45 Type II (Liquid Fuel) Heater, make sure that sufficient fresh air is allowed to enter the tent at all times.

OPERATION IN HIGH ALTITUDE CONDITIONS

Solid And Liquid Fuel Operation

Inspect heater operation more frequently.

Solid Fuel Operation Only

Adjust the damper and base heater door as required to prevent overfiring the heater.

Liquid Fuel Operation Only

Lower than normal operating settings of the flow adjustment knob may be desirable to prevent overfiring and carbon buildup.

OPERATION IN RAINY OR HUMID CONDITIONS

Solid And Liquid Fuel Operation

Be sure the heater unit is installed on solid footing, such as a sandbox or brick base.

If heater has been exposed to rain, drain it of any large water deposits before trying to light it.

Solid Fuel Operation Only

Keep the kindling, coal, and/or wood as dry as possible.

Liquid Fuel Operation Only

Prevent fuel contamination by keeping lids tight on fuel containers.

OPERATION IN SALT WATER AREAS

Solid And Liquid Fuel Operation

Keep the heater free from salt-water contact as much as possible.

Wash the heater frequently with fresh water if exposed to salt spray, to prevent corrosion. Wipe with a rag dampened with light machine oil to prevent rust and corrosion.

NBC DECONTAMINATION PROCEDURES

Perform interim decontamination procedures in accordance with FM 3-5.

END OF WORK PACKAGE

CHAPTER 3

**TROUBLESHOOTING PROCEDURES
FOR THE
H-45 LARGE RADIANT SPACE HEATER**

THIS PAGE INTENTIONALLY LEFT BLANK

**OPERATOR AND UNIT MAINTENANCE
H-45 LARGE RADIANT SPACE HEATER
(TYPE I, SOLID FUEL)
NSN 4520-01-354-1191
(TYPE II, LIQUID FUEL)
NSN 4520-01-329-3451
TROUBLESHOOTING INDEX**

INTRODUCTION TO TROUBLESHOOTING

The troubleshooting index lists common malfunctions that may occur during heater inspection and operation. Find the malfunction the heater is having in the index and go to the given troubleshooting procedure in WP 0008 00, "Troubleshooting Procedures."

These charts cannot list ALL of the malfunctions that may occur, tests or all inspections needed to find the fault, nor actions required to correct the fault. If your malfunction is not listed in or correctable through this troubleshooting index, notify your unit maintenance or your supervisor.

WARNING



The H-45 heater must be shut off and allowed to cool down before any maintenance is performed. Severe burns from contact with heated parts may result.

TROUBLESHOOTING INDEX (OPERATOR)

Malfunction or Symptom	Refer to Troubleshooting Procedure
H-45 Type I (Solid Fuel) Heater	Table 1
Draw gate will not move	1
Heater does not operate properly	2
Excessive dark smoke	3
H-45 Type II (Liquid Fuel) Heater	Table 2
Burner does not fire	1
Heater does not operate properly	2
Excessive dark smoke	3

TROUBLESHOOTING INDEX (UNIT MAINTENANCE)

Malfunction or Symptom	Refer to Troubleshooting Procedure
H-45 Type II (Liquid Fuel) Heater	Table 3
Heater does not start or sputters and misfires during operation	1
H-45 TYPE I (SOLID FUEL) Heater	No Troubleshooting procedures for Solid Fuel mode at the Unit level. If Operator Troubleshooting did not correct the problem, replace the heater.

END OF WORK PACKAGE

THIS PAGE INTENTIONALLY LEFT BLANK

**OPERATOR AND UNIT MAINTENANCE
H-45 LARGE RADIANT SPACE HEATER
(TYPE I, SOLID FUEL)
NSN 4520-01-354-1191
(TYPE II, LIQUID FUEL)
NSN 4520-01-329-3451
TROUBLESHOOTING PROCEDURES**

INITIAL SETUP:**Tools**

General Mechanic's Tool Kit (WP 0041 00, Table 2, Item 1)

References

WP 0005 00, WP 0020 00, WP 0021 00,
WP 0035 00, WP 0036 00, WP 0039 00

Materials

Rags (WP 0052 00, Table 1, Item 4)

Equipment Conditions

Heater shutdown and cool (WP 0005 00)

Personnel Required

One

TROUBLESHOOTING PROCEDURES

The troubleshooting procedures contain tables that list possible malfunctions, the tests or inspections to perform, and the corrective action required to return the H-45 to normal operation. However, this manual cannot list all malfunctions, tests, inspections, or corrective actions that may occur. If a malfunction is not listed or is not corrected by listed corrective actions, notify unit maintenance or your supervisor.

For the procedures that are listed in this manual, perform the steps in the order that they appear in the tables.

DO NOT START THE TASK UNTIL:

1. You understand the task
2. You understand what you are to do
3. You understand what is needed to do the work
4. You have the things you need

Table 1. H-45 Type I (Solid Fuel) Heater Troubleshooting (Operator)

MALFUNCTION	TEST OR INSPECTION	CORRECTIVE ACTION
1. Draw grate will not move	Check for clinkers (burnt wood or coal) lodged in grate openings.	Remove clinkers.
2. Heater does not heat properly	Check to see if base heater door is closed.	Open base heater door.
	Check to see if flue damper is blocked or closed.	Open flue damper. Remove stack, and clean flue damper.
3. Excessive dark smoke	Check to see if too much fuel was added at one time.	Reduce the quantity of fuel but add fuel more often.
	Check for accumulation of soot in stack pipes.	Remove and clean stack pipes.
	Check for accumulation of ashes.	Shake down fire and clean out ashpit.

Table 2. H-45 Type II (Liquid Fuel) Heater Troubleshooting (Operator)

MALFUNCTION	TEST OR INSPECTION	CORRECTIVE ACTION
1. Burner does not fire.	Check to see if fuel can is empty.	Check fuel supply and replenish if necessary. (Refer to WP 0005 00, "Refueling the H-45 Type II (Liquid Fuel) Heater.")
	Check to see if fuel OFF/ON control on fuel flow control is turned to OFF position.	Set fuel OFF/ON control to ON position.
	Check fuel line from fuel can to fuel flow control for air bubbles.	Open primer valve and shake hose assembly to purge air bubbles until a strong flow is achieved.
	Check to see if fuel selector control is improperly set.	Turn fuel selector control to fuel being used. (Refer to WP 0005 00, "Starting the H-45 Type II (Liquid Fuel) Heater.")

Table 2. H-45 Type II (Liquid Fuel) Heater Troubleshooting (Operator)-continued

MALFUNCTION	TEST OR INSPECTION	CORRECTIVE ACTION
2. Heater does not operate properly.	Check fuel line from fuel can to fuel flow control for air bubbles.	Open primer valve and shake hose assembly to purge air bubbles until a strong flow is achieved.
	Accumulation of soot in stack pipe.	Clean stack pipe in accordance with WP 0020 00.
	Fuel selector control set incorrectly.	Follow the procedures in WP 0005 00, "Starting the H-45 Type II (Liquid Fuel) Heater" to determine the correct setting.
	Check if heater is being overfired or underfired.	If heater is overfired, turn flow adjustment knob on fuel flow control counterclockwise to reduce flow rate. If underfired, turn knob clockwise to increase flow rate.
	Check that stack pipe sections are assembled and properly fitted together.	Reassemble any opened pipe sections. Tightly reconnect all pipe sections.
	Check for accumulation of soot in burner cap assembly and burner shell assembly components.	Clean burner cap assembly. Refer to WP 0021 00. Clean burner shell assembly. Refer to WP 0021 00.
	Make sure that automatic vent on gravity feed adaptor is not blocked with ice or snow	Clear obstructions from gravity feed adaptor vent
3. Excessive dark smoke	Check to see if fuel setting is too high.	Turn fuel setting down.
	Check to see if fuel selector is on the correct setting.	Rotate fuel selector knob to correct fuel type being used.
	Check to see if draft doors are open.	Open draft doors.
	Check stack pipe sections for cracks.	Replace cracked sections.
	Check stack for proper number of stack pipe sections.	Failure to use all six stack pipe sections will adversely affect heater performance, increase soot buildup, and increase maintenance. Always use all six sections.
	Check stack for proper fit between stack pipe sections.	Push stack pipe sections together.

Table 3. H-45 Type II (Liquid Fuel) Heater Troubleshooting (Unit)

MALFUNCTION	TEST OR INSPECTION	CORRECTIVE ACTION
1. Heater does not operate at full capacity.	Strainer in fuel flow control valve is clogged.	Clean strainer as described in WP 0039 00.
	Flow control burner hose from fuel flow control valve to burner shell assembly is blocked.	Remove and replace flow control burner hose as described in WP 0036 00.
	Street elbow fitting in burner shell assembly is blocked due to soot or fuel residue.	Clean street elbow as described in WP 0035 00.

END OF WORK PACKAGE

CHAPTER 4

**OPERATOR MAINTENANCE INSTRUCTIONS
FOR THE
H-45 LARGE RADIANT SPACE HEATER**

THIS PAGE INTENTIONALLY LEFT BLANK

**OPERATOR MAINTENANCE
H-45 LARGE RADIANT SPACE HEATER
(TYPE I, SOLID FUEL)
NSN 4520-01-354-1191
(TYPE II, LIQUID FUEL)
NSN 4520-01-329-3451
SERVICE UPON RECEIPT**

GENERAL

The H-45 is shipped from the manufacturer disassembled and must be assembled as described in WP 0005 00. An inventory of the H-45 components is as follows:

Table 1. H-45 Type I (Solid Fuel) Heater Inventory List

Component Description	Illustration Item Number (See WP 0050 00-02 and -03)
Heater body base	1
Top heater shell	2
Lid assembly	3
Stack pipe (6 units)	4
Stack cap assembly	5
Spark arrestor	6
Flue damper	7
Draw grate*	8
Round grate*	9
Cotter pin*	10
Poker	11
Adapter ring	12
Shaker	13
Shovel	14
* These components come pre-assembled from the factory.	

Table 2. H-45 Type II (Liquid Fuel) Heater Inventory List

Component Description	Illustration Item Number (See WP 0050 00-02, -04, and -05)
Heater body base	1
Top heater shell	2
Lid assembly	3
Stack pipe (6 units)	4
Stack cap assembly	5
Flow control bracket	15
Burner cap assembly	16
Burner reaming tool	17
Burner shell assembly	18
Rim clenching clamps (3 each)*	19
Fuel flow control valve	20
Cup/cable assembly	21
Flow control burner hose	22
Collapsible fuel can stand	23
Gravity feed adapter kit	24
High fire ring*	25
Fuel overflow hose	26
Pan head screws (3 each)*	27
Superheater assembly	28
Fuel supply hose	29

* These components come pre-assembled from the factory.

CHECKING UNPACKED EQUIPMENT

Damage. Inspect the equipment for damage incurred during shipment. If the equipment has been damaged, report the damage on SF 364, Report of Discrepancy.

Completeness. Check the equipment against the packing list to see if the shipment is complete. Report all discrepancies in accordance with DA PAM 738-750.

Modifications. Check to see whether the equipment has been modified. Equipment that has been modified will have the Modification Work Order (MWO) number on the case near the instruction plate on the heater body base. Check also to see whether all currently applicable MWOs have been applied. (Current MWOs are listed in DA PAM 25-30.)

BURNING OFF PROTECTIVE PRESERVATIVE FILM PRIOR TO USE

The metal surfaces of the H-45 heater body are protected with a preservative film that must be burned off prior to using the heater in an enclosed area. To burn off the protective film, set up the H-45 in an open outside area and light in accordance with WP 0005 00. Once the heater is hot, smoke will be seen coming off the metal surfaces as the preservative burns off. Allow the heater to burn until no more smoke is observed. Shut the heater down and prepare for movement as detailed in WP 0005 00.

ASSEMBLING STACK SECTIONS, TYPE I (SOLID FUEL) AND TYPE II (LIQUID FUEL)**WARNING**

Wear protective gloves and hold the sheet metal securely while curling it to prevent it from slipping and causing severe cuts.

NOTE

Prior to the initial use of the H-45 Type I (Solid Fuel) Heater, one section of the stack pipe assembly must have the flue damper installed. This procedure is detailed later in this work package.

Before the H-45 can be used for the first time, the individual stack sections must be assembled. The stack sections are provided as slightly curved sheet metal sections having seams that must be locked together. Once locked, they cannot be taken apart. The sections are then transported in an assembled state with the heater.

To assemble each stack section for first time use, join the formed edges of one of the curved sheets of metal to form a cylindrical pipe **(1)**. To do this, engage the flat seam section **(2)** into the crimped seam section **(3)** at one end of the section. Fully engage the seam **(4)** along its entire length.

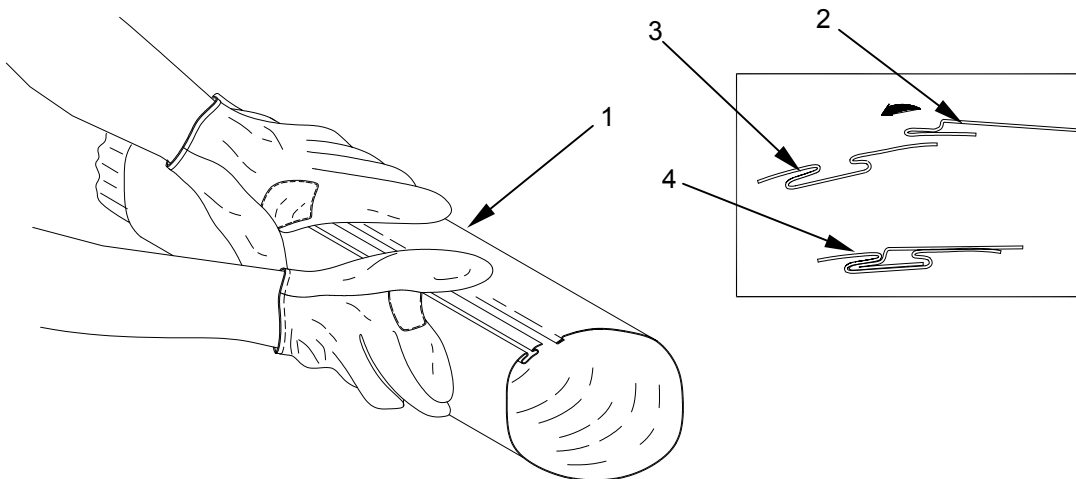

INSTALLING THE FLUE DAMPER, TYPE I (SOLID FUEL)

NOTE

The flue damper shaft may be used to punch the 1/4-inch hole in the stack section if a drill is unavailable.

1. To install the flue damper, select one of the assembled sections (1) and measure its length. Make a mark (2) halfway down the length of the section at a point 90 degrees away from the section seam (3). Make a second mark (4) directly opposite the first mark (2) on the other side of the stack section (1). Drill (or punch) a 1/4-inch hole at each mark. After drilling the two holes, insert the flue damper (5) inside the modified section (6) and align the holes passing through the flue damper with the holes drilled in the side of the stack section.
2. Thread the flue damper shaft (7) through the holes, locking the curved shank (8) of the flue damper shaft (7) into the center slot (9) of the flue damper. When properly locked together, the flue damper and operating handle (10) will be parallel.

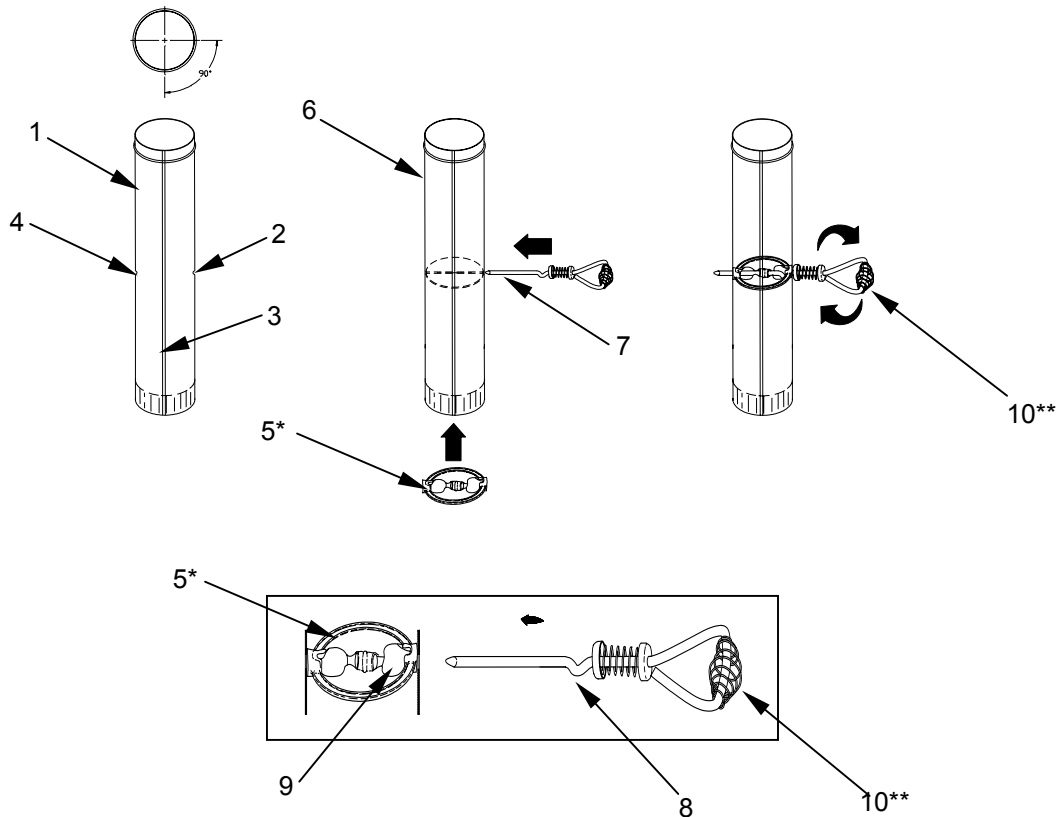

END OF WORK PACKAGE

**OPERATOR MAINTENANCE
H-45 LARGE RADIANT SPACE HEATER
(TYPE I, SOLID FUEL)
NSN 4520-01-354-1191
(TYPE II, LIQUID FUEL)
NSN 4520-01-329-3451**

OPERATOR PREVENTIVE MAINTENANCE CHECK AND SERVICES (PMCS), INTRODUCTION

INTRODUCTION

The heater components must be inspected regularly to find and correct defects. Record all defects found during the performance of PMCS and the steps taken to correct them on a DA Form 2404, Equipment Inspection and Maintenance Worksheet. Instructions for reporting/ correcting noted deficiencies are contained in DA PAM 738-750.

General. Tables 1 and 2 (PMCS Tables) have been provided so you can keep your equipment in good operating condition and ready for its primary mission.

Warnings and Cautions. Always observe the WARNINGS and CAUTIONS appearing in your PMCS table. Warnings and cautions appear before applicable procedures. You must observe these WARNINGS and CAUTIONS to prevent serious injury to yourself and others or to prevent your equipment from being damaged.

EXPLANATION OF TABLE ENTRIES

Item number column. Numbers in this column are for reference. When completing DA Form 2404 (Equipment Inspection and Maintenance Worksheet), include the item number for the check/ service indicating a fault. Item numbers also appear in the order that you must do checks and services for the intervals listed.

Interval column. This column tells you when you must do the procedure in the procedure column. BEFORE procedures must be done before you use or operate the equipment for its intended mission. DURING procedures must be done during the time you are operating or using the equipment for its intended mission. AFTER procedures must be done immediately after you have operated or used the equipment.

Location, check/ service column. This column lists the item that must be checked or serviced to know if the item is ready or available for its intended mission or for operation. You must check or service the item at the time stated in the interval column.

Procedure column. This column gives the procedure you must do to check or service the item listed in the check/ service column to know if the equipment is ready or available for its intended mission or for operation. You must do the procedure at the time stated in the interval column.

Not fully mission capable if: column. Information in this column tells you what faults will keep your equipment from being capable of performing its primary mission. If you make check and service procedures that show faults listed in this column, do not operate the equipment. Follow standing operating procedures for maintaining the equipment or reporting equipment failure.

Other Table Entries. Be sure to observe all special information and notes that appear in your table.

END OF WORK PACKAGE

THIS PAGE INTENTIONALLY LEFT BLANK

**OPERATOR MAINTENANCE
H-45 LARGE RADIANT SPACE HEATER
(TYPE I, SOLID FUEL)
NSN 4520-01-354-1191
(TYPE II, LIQUID FUEL)
NSN 4520-01-329-3451**

OPERATOR PREVENTIVE MAINTENANCE CHECKS AND SERVICES (PMCS), PROCEDURES

INITIAL SETUP:**Materials**

Absorbent Material (WP 0052 00, Table 1, Item 1)
Brush (WP 0052 00, Table 1, Item 3)
Gloves (WP 0051 00, Table 1)
Lubricating Oil (WP 0052, Table 1, Item 5)
Rags (WP 0052 00, Table 1, Item 7)

Personnel Required

One

References

WP 0005 00

Equipment Conditions

Heater shut down and cool (WP 0005 00)

NOTE

If the equipment must be kept in continuous operation, do only the procedures that can be done without disturbing operation. Make complete checks and services when the equipment is shut down.

Table 1. Preventive Maintenance Checks and Services for H-45 Type I (Solid Fuel) Heater

Item No.	Interval	Item To Be Checked Or Serviced	Procedure	Equipment Not Ready/ Available If:
1	Before	Grate (1)	Check for smooth operation, cracks, warping.	Grate cannot support fuel or does not operate properly.
2	Before	Spark Arrester (2)	Inspect for snug fit and leaks.	Leaks or cannot be put on pipe.
3	Before	Flue Damper (3)	Check for proper operation.	Damper does not operate.
4	Before	Top Heater Shell and Heater Body Base (4)	Clean heater of foreign matter, soot, or residue. Check for bent flanges on top heater shell. Check for damaged bolts, loose or missing wing nuts.	Lid assembly or stack pipe assembly cannot be installed.

NOTE

If the equipment must be kept in continuous operation, do only the procedures that can be done without disturbing operation. Make complete checks and services when the equipment is shut down.

Table 1. Preventive Maintenance Checks and Services for H-45 Type I (Solid Fuel) Heater-Continued

Item No.	Interval	Item To Be Checked Or Serviced	Procedure	Equipment Not Ready/ Available If:
5	Before	Base Heater Doors (5)	Inspect doors for alignment.	Doors do not open.
6	Before	Grate Heater Doors (6)	Inspect doors for alignment.	Doors does not open.
7	Before	Stack Pipe Assembly (7)	Inspect for dents. Clean soot.	Pipe sections bent out of shape or do not fit together.
8	Before	Stack Cap Assembly (8)	Inspect tent lines, wire ropes for damage.	
9	During	Spark Arrester (2)	Inspect for snug fit and leaks.	Leaks.
10	During	Ashes and Clinkers	Remove every 3 to 4 hours.	
11	During	Stack Cap Assembly (8)	Inspect tent lines, wire ropes for damage.	
12	After	Spark Arrester (2)	Clean soot and residue as required.	
13	After	Top Heater Shell and Heater Body Base (4)	Clean heater of foreign matter, soot, or residue.	

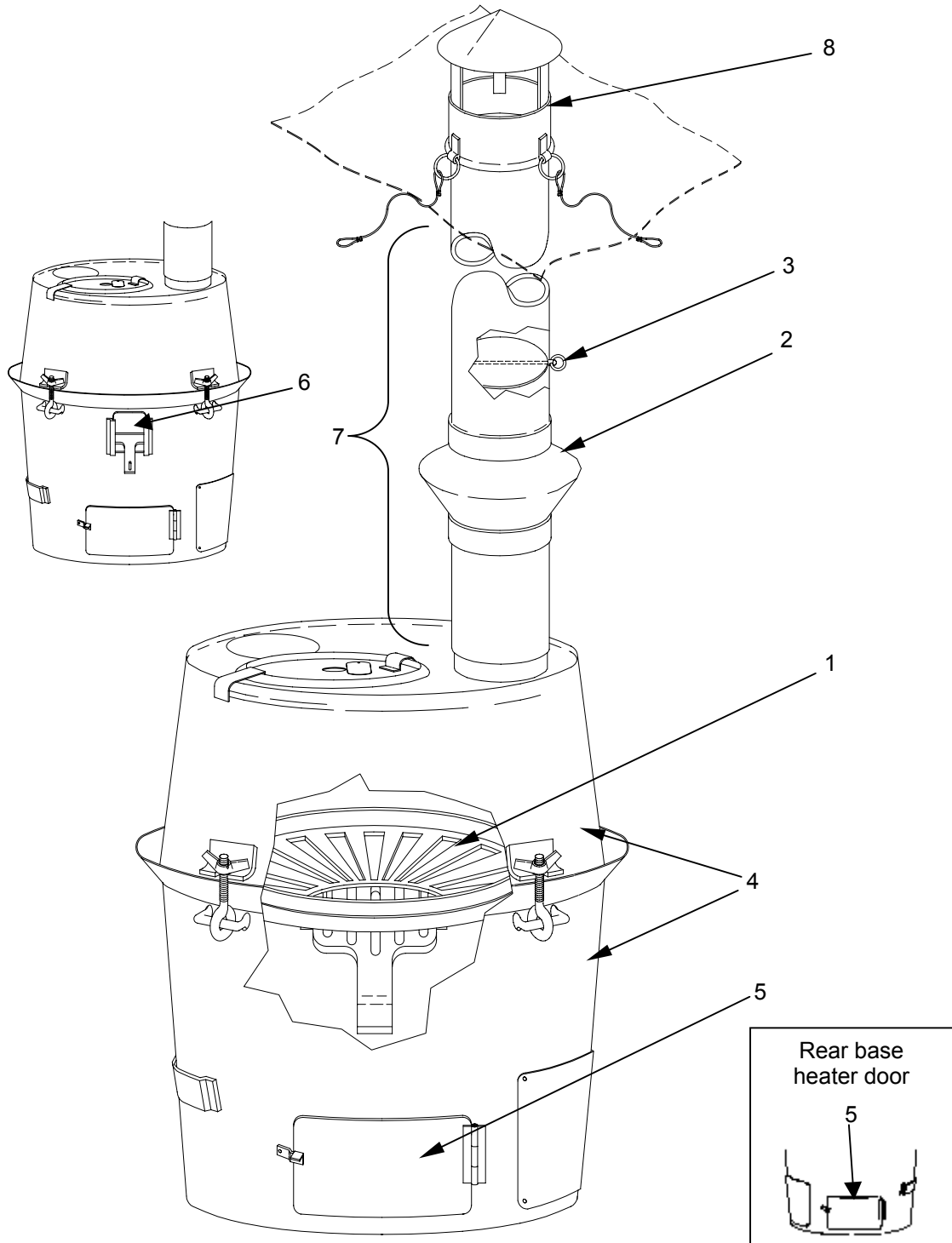
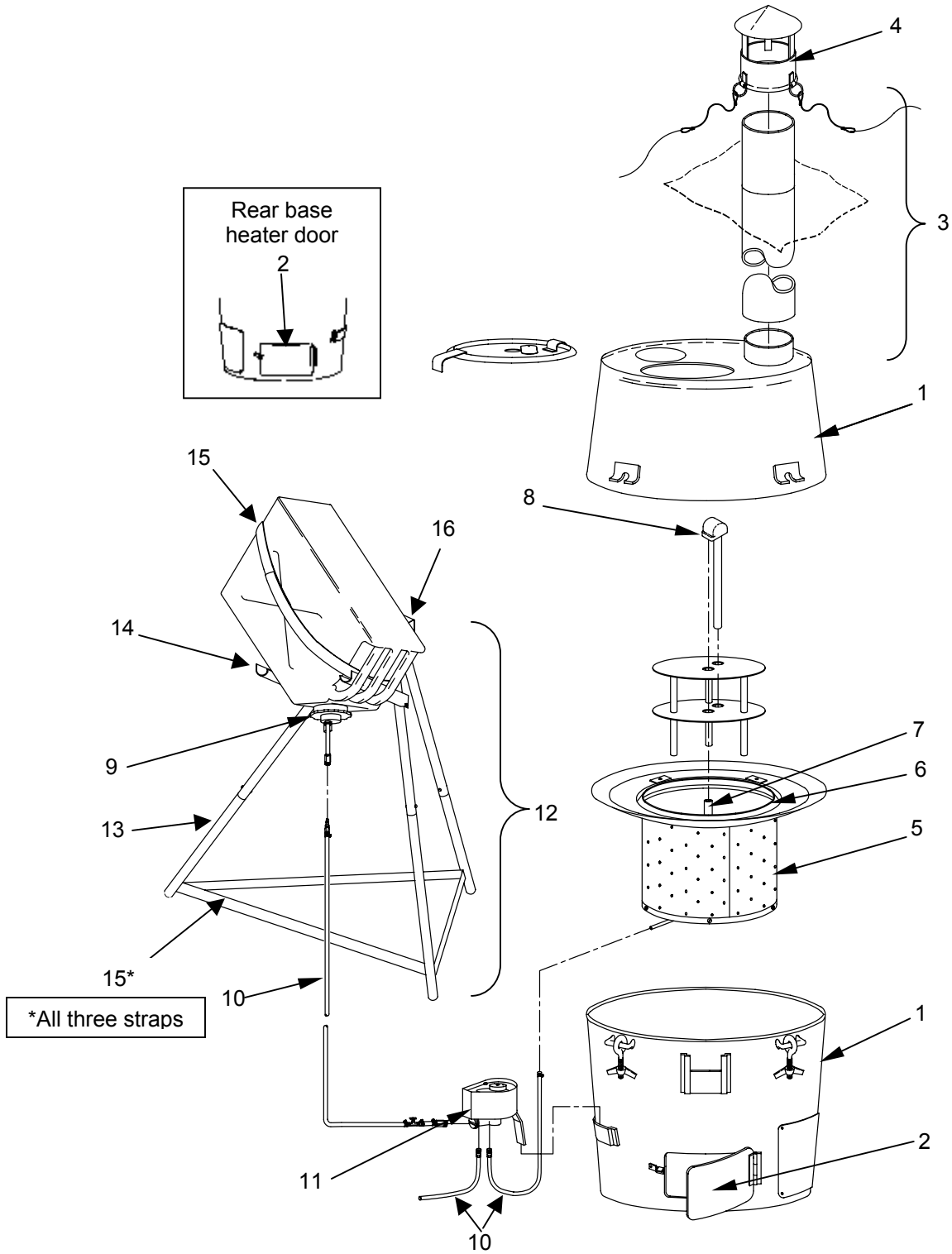

Table 2. Preventive Maintenance Checks and Services for H-45 Type II (Liquid Fuel) Heater

Item No.	Interval	Item To Be Checked Or Serviced	Procedure	Equipment Not Ready/ Available If:
1	Before	Top Heater Shell and Heater Body Base (1)	<p>Clean heater of foreign matter, soot, or residue.</p> <p>Check for bent flanges on top heater shell.</p> <p>Check for damaged bolts, loose or missing wing nuts.</p>	Lid assembly or stack pipe cannot be installed.
2	Before	Base Heater Doors (2)	Inspect doors for alignment.	Doors do not open.
3	Before	Stack Pipe Assembly (3)	Inspect for dents. Clean soot from pipe.	Pipes bent out of shape or do not fit together.
4	Before	Stack Cap Assembly (4)	<p>Inspect tent lines and wire ropes for damage.</p> <p>Check cap for damage.</p>	
5	Before	Burner Shell Assembly (5)	Check for bends, dents, and rough edges.	Burner cannot be properly mounted.
6	Before	High Fire Ring (6)	High fire ring not secured or fully seated. Check for soot and residue.	Loose, missing, or bent retainers. High fire ring not fully seated.
7	Before	Burner Up Tube (7) and Burner Cap Assembly (8)	Check for foreign matter, soot, and residue.	Components not clean.
8	Before	Gravity Feed Adapter (9)	Inspect gravity feed adapter for missing or defective parts.	Any fuel leaks. Gravity feed adapter damaged or parts missing.
9	Before	Hose Assemblies (10)	Inspect for cuts, punctures, and serviceable fittings.	Any fuel leaks. Hose assemblies damaged or fittings unserviceable.
10	Before	Fuel Flow Control (11)	Inspect for proper operation.	Control leaks or does not operate properly.
11	Before	Fuel Can Stand (12)	<p>Check fuel can stand (12) for bent legs (13) and damaged or missing support arms (14). Check for frayed or broken straps (15).</p> <p>Check clip (16) to make sure it is not broken or missing. If fuel can stand is damaged replace it.</p>	Stand cannot securely support full fuel can.



**Table 2. Preventive Maintenance Checks and Services for H-45 Type II (Liquid Fuel) Heater-
Continued**

Item No.	Interval	Item To Be Checked Or Serviced	Procedure	Equipment Not Ready/ Available If:
11	During	Gravity Feed Adapter (1)	Inspect adapter kit for missing or defective parts.	Any fuel leaks. Kit damaged or parts missing.
12	During	Hose Assemblies (2)	Inspect for cuts, punctures, and serviceable fittings.	Any fuel leaks. Hose assemblies damaged or fittings unserviceable.
13	During	Stack Cap Assembly (3)	Inspect tent lines, wire ropes for damage. Check cap for damage.	
14	After	Top Heater Shell and Heater Body Base (4)	Clean heater of foreign matter, soot, or residue.	
15	After	Burner Shell Assembly (5)	Check for soot or residue plugging burner holes.	Burner not clean.

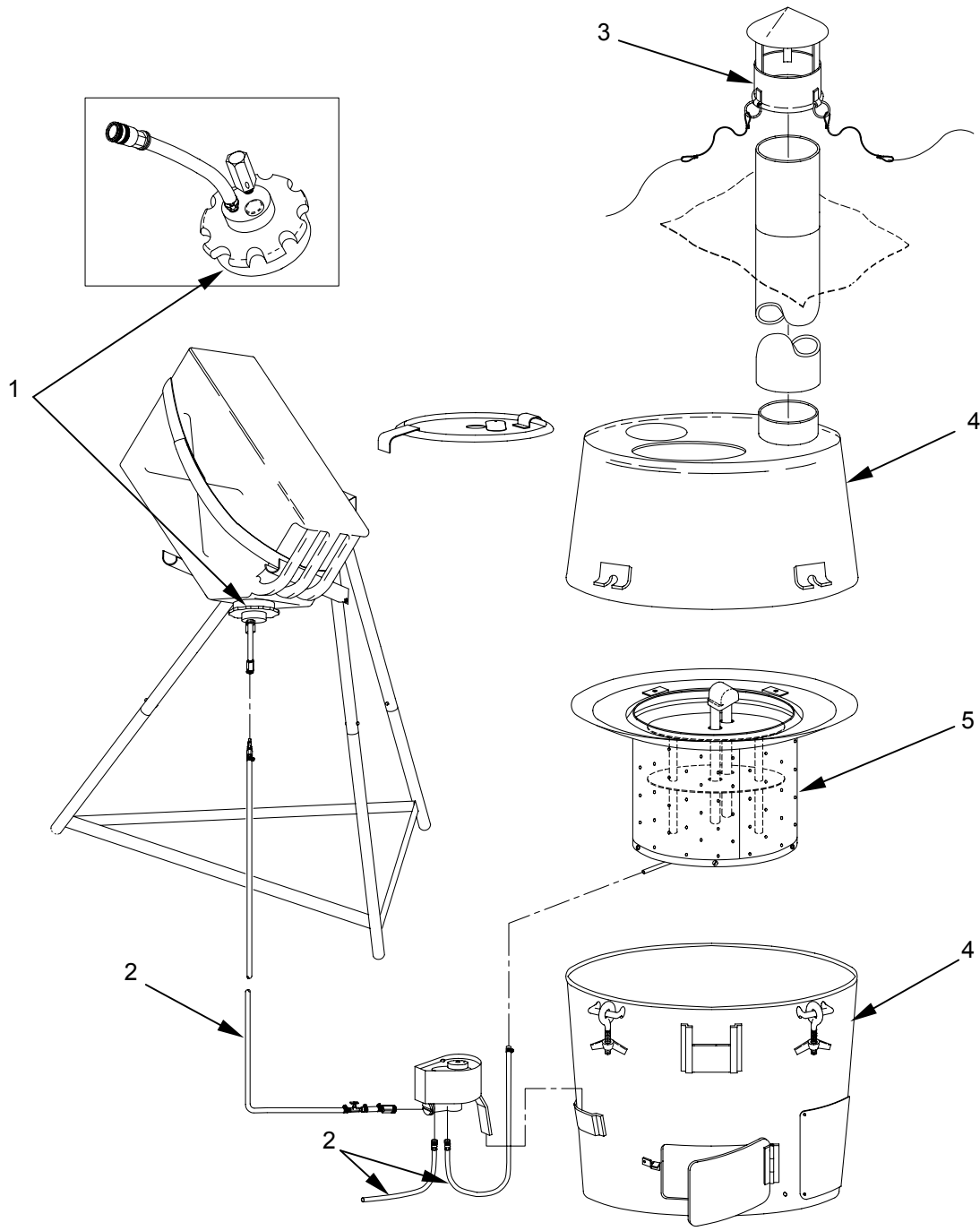

LUBRICATION REQUIREMENTS.

The door hinges, door latch assemblies, bolt and wing nut assemblies, and sight glass cover should be lubricated with a light machine oil when stored.

END OF WORK PACKAGE

**OPERATOR MAINTENANCE
H-45 LARGE RADIANT SPACE HEATER
(TYPE I, SOLID FUEL)
NSN 4520-01-354-1191
(TYPE II, LIQUID FUEL)
NSN 4520-01-329-3451
INTRODUCTION**

INTRODUCTION

This section contains Operator Maintenance applicable to the H-45 as authorized by the Maintenance Allocation Chart (MAC) in WP 0041 00 of this manual.

All maintenance procedures in this section can be performed by one person unless otherwise indicated.

Read all WARNING, CAUTION, and NOTE statements carefully before attempting the procedures. This includes the warnings at the front of this manual.

Each maintenance item will include a heading that lists the action to be taken, the tools and parts and/or materials required, and the condition the equipment must be in to perform the action.

INSPECT

Refer to WP 00011 00, Table 1, Operator PMCS for the H-45 Type I (Solid Fuel) Heater, and Table 2, Operator PMCS for the H-45 Type II (Liquid Fuel) Heater for inspection procedures.

END OF WORK PACKAGE

THIS PAGE INTENTIONALLY LEFT BLANK

OPERATOR MAINTENANCE
H-45 LARGE RADIANT SPACE HEATER
 (TYPE I, SOLID FUEL)
 NSN 4520-01-354-1191
 (TYPE II, LIQUID FUEL)
 NSN 4520-01-329-3451
HEATER BODY BASE
INSPECT, SERVICE (BOTH TYPES)
REPLACE (TYPE I ONLY)

INITIAL SETUP:**Materials**

Absorbent Material (WP 0052 00, Table 1, Item 1)
 Brush (WP 0052 00, Table 1, Item 3)
 Rags (WP 0052 00, Table 1, Item 7)

Personnel Required

One

Reference

WP 0005 00

Equipment Condition

H-45 shutdown and cool (WP 0005 00)
 Guy lines anchoring stack pipe untied from stakes (WP 0005 00)

H-45 TYPE I (SOLID FUEL) HEATER**REMOVE**

1. Remove the stack pipe assembly (1) from the stack flange (2) on the top heater shell (3).
2. Loosen the wing nuts on the bolt and wing nut assemblies (4) holding the top heater shell (3) to the heater body base (5), remove the bolt and wing nut assemblies (4) from the brackets (6), and remove the top heater shell (3). Remove the grates (7) and adapter ring (8).

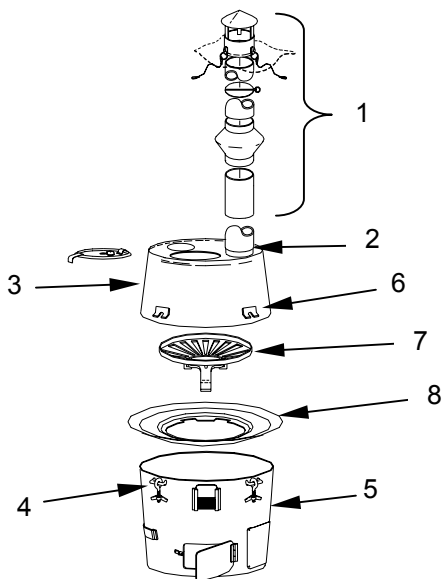

INSPECT

1. Inspect the heater body base **(1)** and doors **(2)** internally and externally for cracks, distortion, holes burned through the metal, or rust. If the heater body base **(1)** is damaged replace it. If the doors **(2)** are damaged or missing, contact unit maintenance.
2. Inspect the door latches **(3)** to check if they are damaged or missing. If the door latches are damaged or missing, contact unit maintenance.

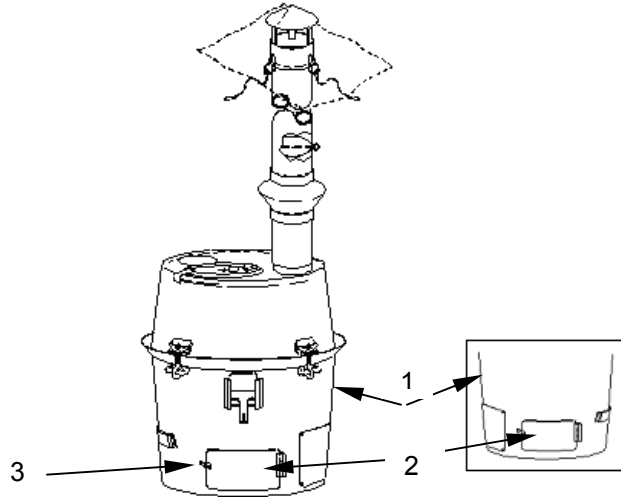
**SERVICE**

Clean any soot, carbon deposits, or fuel residue from the heater body base **(1)** with a rag and/or brush.

REPLACE (TYPE I ONLY)

If heater body base is damaged, replace it.

INSTALL (REFER TO WP 0005 00)

1. Install the adapter ring.
2. Install the grates.
3. Install the top heater shell.
4. Install the stack pipe assembly.

H-45 TYPE II (LIQUID FUEL) HEATER**REMOVE**

1. Remove the fuel can (1) from the fuel can stand (2) and place the fuel can (1) upright on the ground.
2. Remove the stack pipe assembly (3) from the stack flange (4) on the top heater shell (5).
3. Place an absorbent pad under the fuel flow control valve (6), and disconnect the female QD fitting (7) on the flow control burner hose (8) from the flow control burner male QD fitting (9) on the fuel flow control valve (6).
4. Loosen the wing nuts on the bolt and wing nut assemblies (10) holding the top heater shell (5) to the heater body base (11), remove the bolt and wing nut assemblies (10) from the brackets (12), and remove the top heater shell (5).
5. Remove the burner shell assembly (13) from the heater body base (11).

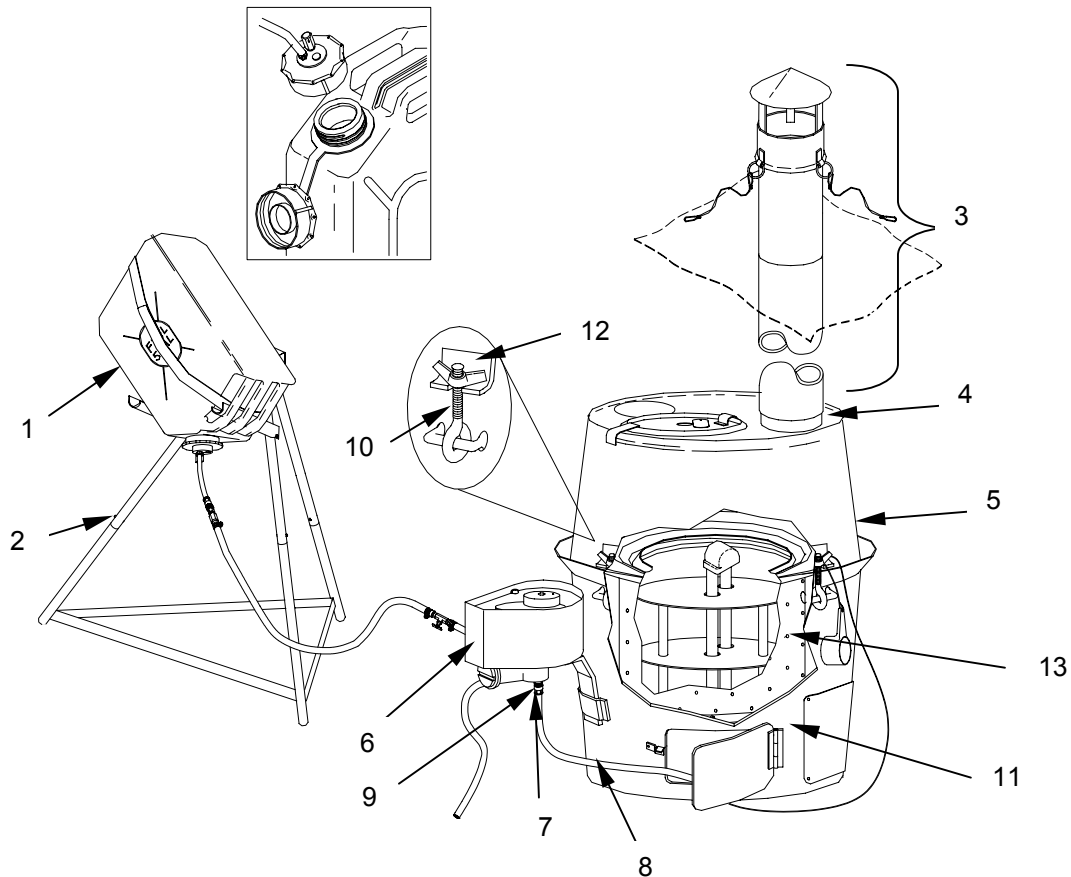

INSPECT

1. Inspect the heater body base (1) and doors (2) internally and externally for cracks, distortion, holes burned through the metal, or rust. If the heater body base (1) is damaged or if the doors (2) are damaged or missing, contact unit maintenance. Unit maintenance will have to install the cup and cable assembly in the replacement heater body base (1).
2. Inspect the door latches (3) to check if they are damaged or missing. If the door latches (3) are damaged or missing, contact unit maintenance.
3. Inspect the cup and cable assembly (4). If damaged or missing, contact unit maintenance.

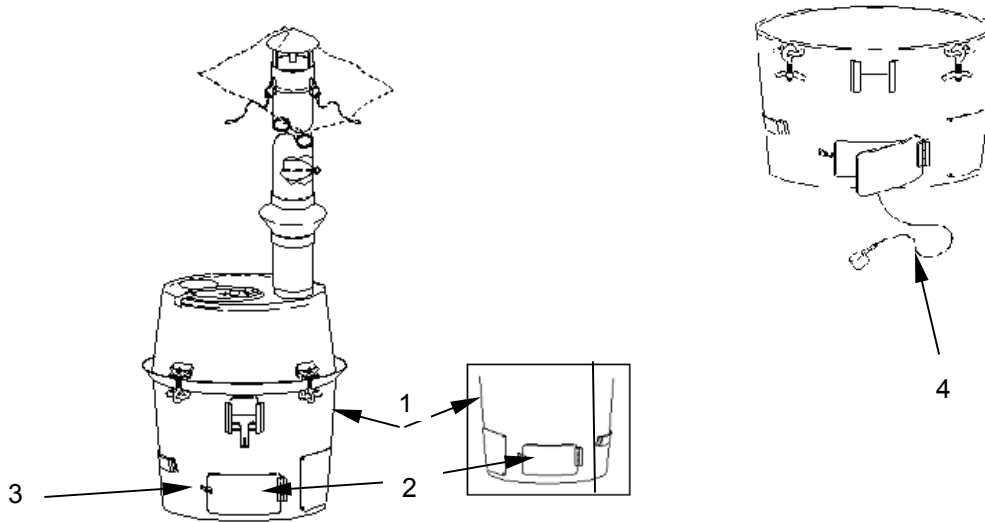
**SERVICE**

Clean any soot, carbon deposits, or fuel residue from the heater body base (1) with a rag and/or brush.

INSTALL (REFER TO WP 0005 00)

1. Install the burner shell assembly.
2. Connect the female QD fitting on the flow control burner hose to the flow control burner male QD fitting on the fuel flow control valve.
3. Install the top heater shell.
4. Install the stack pipe assembly.
5. Place the fuel can in the fuel can stand.

END OF WORK PACKAGE

**OPERATOR MAINTENANCE
H-45 LARGE RADIANT SPACE HEATER
(TYPE I, SOLID FUEL)
NSN 4520-01-354-1191
(TYPE II, LIQUID FUEL)
NSN 4520-01-329-3451
TOP HEATER SHELL
INSPECT, SERVICE, REPLACE**

INITIAL SETUP:**Materials**

Brush (WP 0052 00, Table 1, Item 3)
Rags (WP 0052 00, Table 1, Item 7)

References

WP 0005 00

Personnel Required

One

Equipment Condition

H-45 shutdown and cool (WP 0005 00)
Guy lines anchoring stack pipe untied from
stakes (WP 0005 00)

H-45 TYPE I (SOLID FUEL) AND TYPE II (LIQUID FUEL) HEATERS**REMOVE**

1. Remove the stack pipe assembly **(1)** from the top heater shell **(2)**.
2. Remove the lid assembly **(3)**.
3. Loosen the three wing nuts on the bolt and wing nut assemblies **(4)** holding the top heater shell **(2)** to the heater body base **(5)** and remove the bolt and wing nut assemblies **(4)** from the brackets **(6)**.
4. Remove the top heater shell **(2)**.

INSPECT

1. Inspect the lid assembly **(3)** for cracks, distortion, holes burned through the metal, or rust.
2. Inspect the top heater shell **(2)** for cracks, distortion, holes burned through the metal, or rust.

SERVICE

1. Clean any soot, carbon deposits, or fuel residue from the lid assembly **(3)** with a rag and /or brush.
2. Clean any soot, carbon deposits, or fuel residue from the top heater shell **(2)** with a rag and /or brush.

REPLACE

1. If the lid assembly **(3)** is damaged, replace it.
2. If the top heater shell **(2)** is damaged, replace it.

INSTALL

1. Position the top heater shell (2) on the heater body base (5), and position the lid assembly (3) on the top heater shell (2).
2. Slide the bolt and wing nut assemblies (4) into the brackets (6) attached to the top heater shell (2) and tighten the wing nuts to secure the top heater shell (2) to the heater body base (5).
3. Install the stack pipe assembly (1).

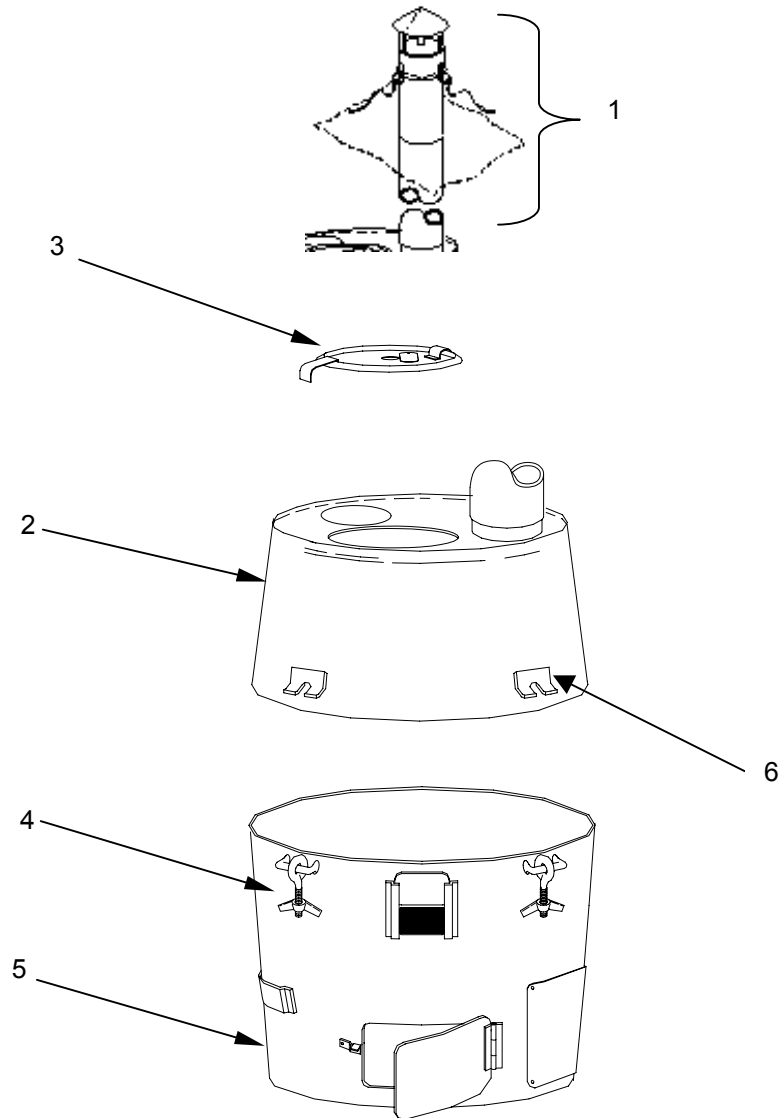
**END OF WORK PACKAGE**

**OPERATOR MAINTENANCE
H-45 LARGE RADIANT SPACE HEATER
(TYPE I, SOLID FUEL)
NSN 4520-01-354-1191
ADAPTER RING
INSPECT, SERVICE, REPLACE**

INITIAL SETUP:**Materials/Parts**

Brush (WP 0052 00, Table 1, Item 3)
Rags (WP 0052 00, Table 1, Item 7)

Personnel Required

One

References

WP 0005 00

Equipment Condition

H-45 shutdown and cool (WP 0005 00)
Guy lines anchoring stack pipe untied from
stakes (WP 0005 00)

H-45 TYPE I (SOLID FUEL) HEATER**REMOVE**

1. Remove the stack pipe assembly **(1)** from the stack flange **(2)** on the top heater shell **(3)**.
2. Loosen the wing nuts on the bolt and wing nut assemblies **(4)** holding the top heater shell **(3)** to the heater body base **(5)**, remove the bolt and wing nut assemblies **(4)** from the brackets **(6)**, and remove the top heater shell **(3)**. Remove the grates **(7)** and adapter ring **(8)**.

INSPECT

Inspect the adapter ring **(8)** for cracks, distortion, holes burned through, or rust.

SERVICE

Clean any soot or carbon deposits from adapter ring **(8)** with a rag or a brush.

REPLACE

Replace the adapter ring **(8)** if damaged.

INSTALL (REFER TO WP 0005 00)

1. Install the adapter ring **(8)**.
2. Install the grates **(7)**.
3. Install the top heater shell **(3)**.
4. Install the stack pipe assembly **(1)**.

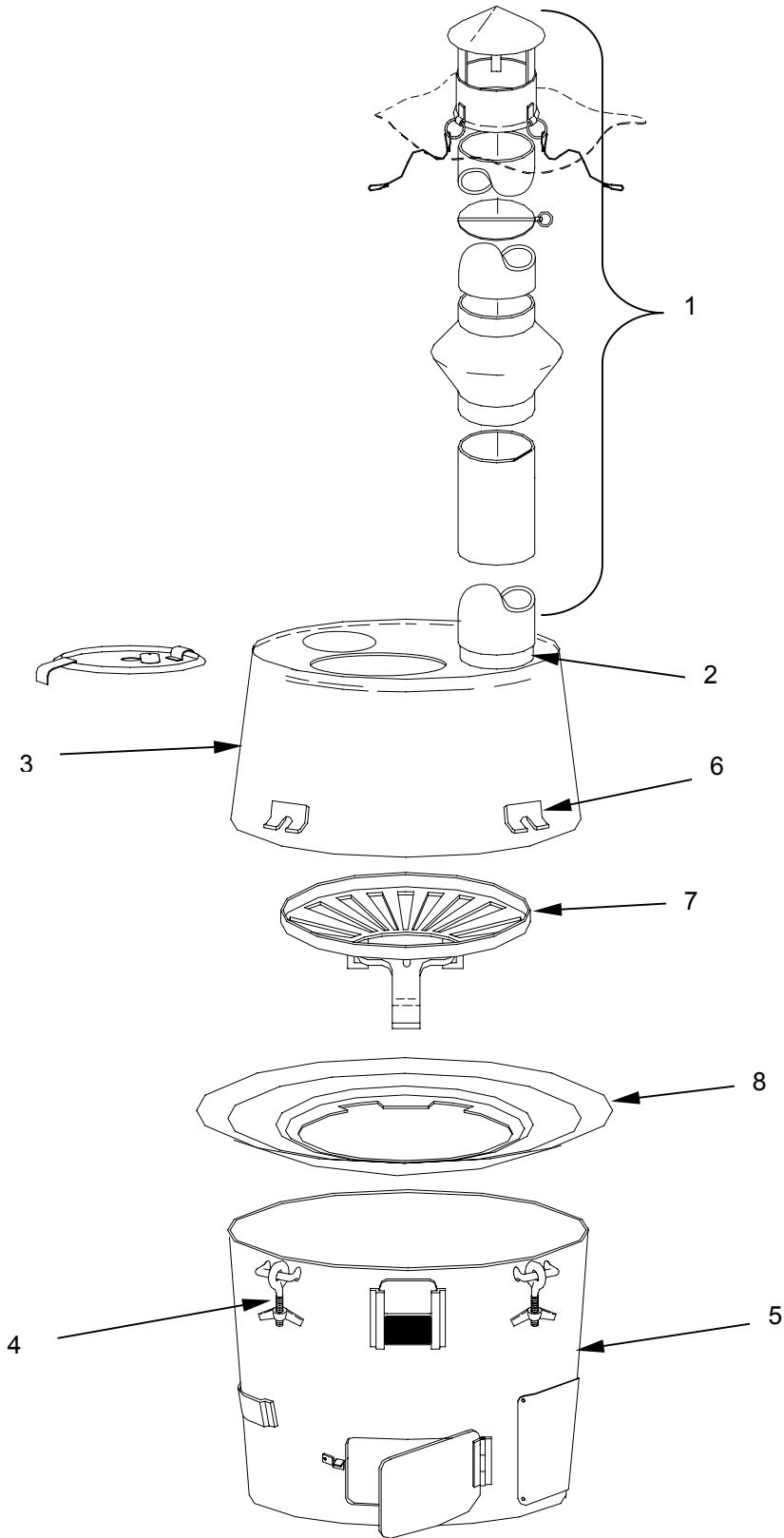

END OF WORK PACKAGE

OPERATOR MAINTENANCE
H-45 LARGE RADIANT SPACE HEATER
(TYPE I, SOLID FUEL)
NSN 4520-01-354-1191
GRATE ASSEMBLY
INSPECT, SERVICE, REPLACE

INITIAL SETUP:**Materials**

Brush (WP 0052 00, Table 1, Item 3)

Rags (WP 0052 00, Table 1, Item 7)

Personnel Required

One

References

WP 005 00

Equipment Condition

H-45 shutdown and cool (WP 0005 00)

Guy lines anchoring stack pipe untied from stakes

(WP 0005 00)

H-45 TYPE I (SOLID FUEL) HEATER**REMOVE**

1. Remove the stack pipe assembly (1) from the stack flange (2) on the top heater shell (3).
2. Loosen the wing nuts on the bolt and wing nut assemblies (4) holding the top heater shell (3) to the heater body base (5), remove the bolt and wing nut assemblies (4) from the brackets (6), and remove the top heater shell (3). Remove the grate assembly (7).

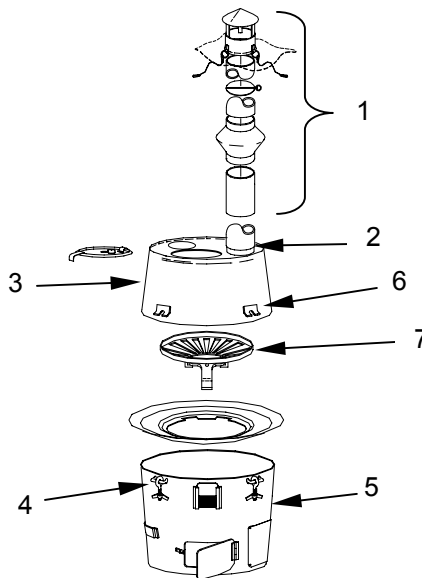

INSPECT

Check the round grate (1) and draw grate (2) for proper operation. Check for corrosion, cracks, or rusted metal. Check the condition of the cotter pin (3). Contact unit maintenance if the grates or cotter pin are damaged or need to be replaced.

SERVICE

Clean round grate (1) and draw grate (2) of ash and clinkers.

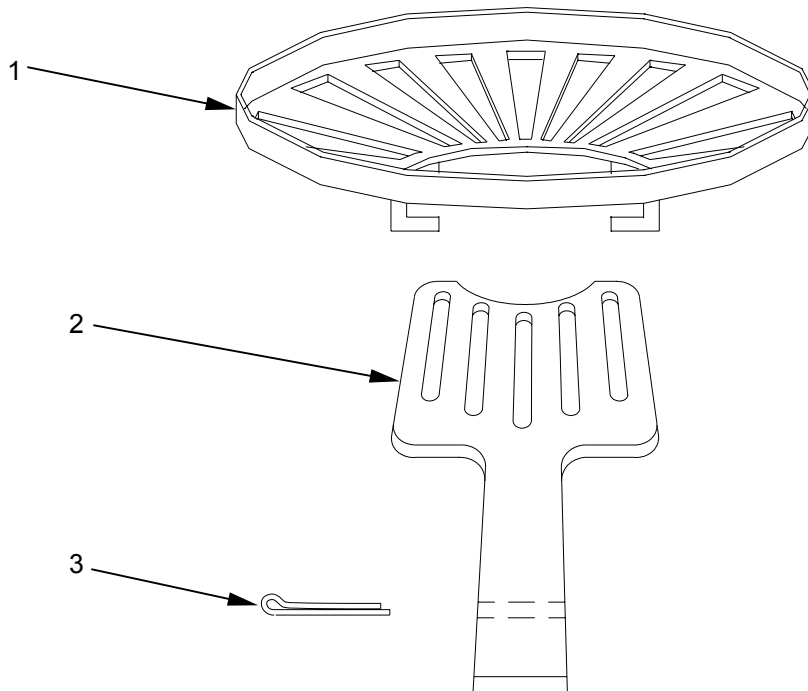
**REPLACE**

If the entire assembly needs to be replaced, replace it. If one of the grates or the cotter pin needs to be repaired or replaced, contact unit maintenance.

INSTALL (REFER TO WP 0005 00)

1. Install the grates.
2. Install the top heater shell.
3. Install the stack pipe assembly.

END OF WORK PACKAGE

OPERATOR MAINTENANCE
H-45 LARGE RADIANT SPACE HEATER
(TYPE I, SOLID FUEL)
NSN 4520-01-354-1191
(TYPE II, LIQUID FUEL)
NSN 4520-01-329-3451
STACK CAP ASSEMBLY
INSPECT, SERVICE, REPLACE

INITIAL SETUP:**Materials**

Brush (WP 0052 00, Table 1, Item 3)
Cord (WP 0046 00, Item 2)
Rags (WP 0052 00, Table 1, Item 7)

Personnel Required

One

Equipment Condition

H-45 shutdown and cool (WP 0005 00)
Guy lines anchoring stack pipe untied from
stakes (WP 0005 00)

H-45 TYPE I (SOLID FUEL) AND TYPE II (LIQUID FUEL) HEATERS**REMOVE**

1. Remove the stack pipe assembly (1) from the stack flange (2) on the top heater shell (3).
2. Remove the stack cap assembly (4) from the stack pipe assembly (1).

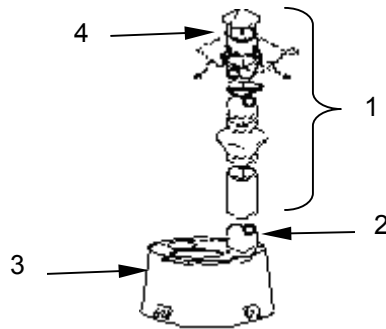

INSPECT

1. Inspect the guy lines **(1)** for frayed, worn, or broken condition.
2. Inspect the stack cap **(2)** for bends, dents, and other deformities. Refer the damaged stack cap assembly **(2)** to unit maintenance.
3. Examine the security of the wire ropes **(3)** and attachment rings **(4)** on the stack cap **(2)**.

SERVICE

1. Using a brush and/or rag, clean any soot or carbon deposits from the stack cap assembly **(2)**.
2. If necessary, re-tie the loose guy lines **(1)** to the wire ropes **(3)**, using a double overhand knot.

REPLACE

1. If the wire ropes **(3)** and attachment rings **(4)** are not secure, replace the stack cap assembly **(2)**.
2. Replace any missing or frayed guy lines **(1)** with cotton tent line cut to a 15 to 25 foot (4.57 to 7.62 m) length depending on the type of tent being used.

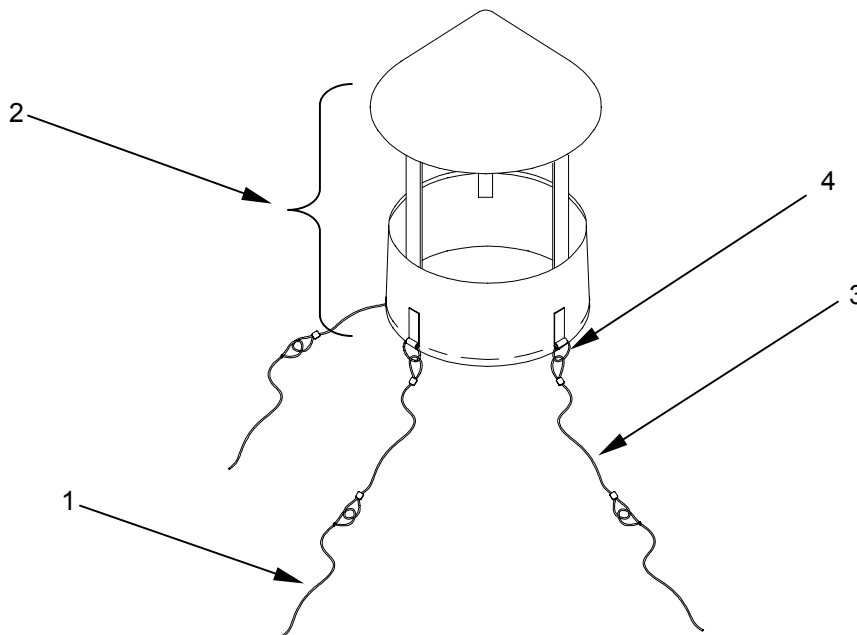
**INSTALL (REFER TO WP 0005 00)**

1. Install the stack cap assembly on the stack pipe assembly.
2. Install the stack pipe assembly on the stack flange on the top heater shell.

END OF WORK PACKAGE

**OPERATOR MAINTENANCE
H-45 LARGE RADIANT SPACE HEATER
(TYPE I, SOLID FUEL)
NSN 4520-01-354-1191
FLUE DAMPER
INSPECT, SERVICE, REPLACE**

H-45 TYPE I (SOLID FUEL) HEATER**INITIAL SETUP:****Materials**

Brush (WP 0052 00, Table 1, Item 3)

Rags (WP 0052 00, Table 1, Item 7)

Equipment Condition

H-45 shutdown and cool (WP 0005 00)

Guy lines anchoring stack pipe untied from stakes (WP 0005 00)

Personnel Required

One

REMOVE

1. Remove the stack pipe assembly **(1)** from the stack flange **(2)** on the top heater shell **(3)**.
2. Remove the stack pipe section **(4)** containing the flue damper **(5)** from the stack pipe assembly **(1)**.
3. Grasp flue damper handle **(6)**, and press firmly against the handle **(6)**. Rotate the flue damper shaft **(7)** until the curved flue damper shank **(8)** is unlocked from the flue damper **(5)**.
4. Remove the curved flue damper shank **(8)** from the stack pipe section **(4)**. Remove the flue damper **(5)** from the stack pipe section **(4)**.

INSPECT

Inspect the flue damper **(5)** for evidence of wear, cracks, or distortion. Check for proper operation. Replace if damaged.

SERVICE

Using a brush and/or rags, clean soot from flue damper parts.

REPLACE

Replace the flue damper if damaged.

INSTALL (REFER TO WP 0005 00)

1. Install the flue damper **(5)** in the stack pipe section **(4)**.
2. Install the stack pipe section **(4)** in the stack pipe assembly **(1)**, and place the stack pipe assembly **(1)** on the stack flange **(2)** on the top heater shell **(3)**.

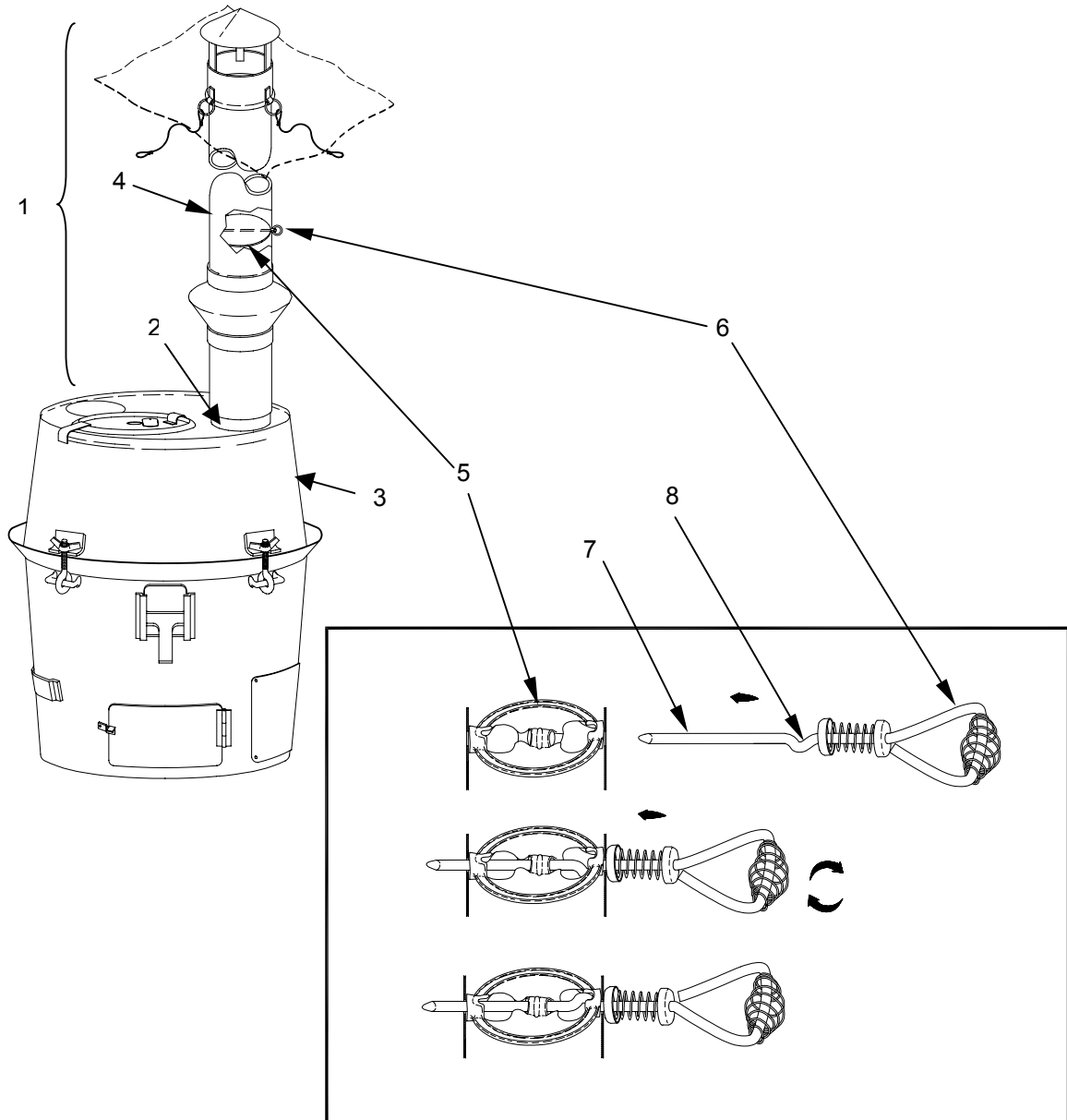

END OF WORK PACKAGE

**OPERATOR MAINTENANCE
H-45 LARGE RADIANT SPACE HEATER
(TYPE I, SOLID FUEL)
NSN 4520-01-354-1191
SPARK ARRESTER
INSPECT, SERVICE, REPLACE**

INITIAL SETUP:**Materials**

Brush (WP 0052 00, Table 1, Item 3)
Rags (WP 0052 00, Table 1, Item 7)

Equipment Condition

H-45 shutdown and cool (WP 0005 00)
Guy lines anchoring stack pipe untied from
stakes (WP 0005 00)

Personnel Required

One

H-45 TYPE I (SOLID FUEL) HEATER**REMOVE**

1. Remove the stack pipe assembly **(1)** from the stack flange **(2)** on the top heater shell **(3)**.
2. Remove the spark arrester **(4)** from the stack pipe assembly **(1)**.

INSPECT

Inspect the spark arrester **(4)** for holes and clogged condition.

SERVICE

Using a brush and/or rags, clean the soot from the spark arrester **(4)**.

REPLACE

Replace the spark arrester if damaged **(4)**.

INSTALL (REFER TO WP 0005 00)

1. Install the spark arrester on the stack pipe assembly.
2. Install the stack pipe assembly on the stack flange on the top heater shell.

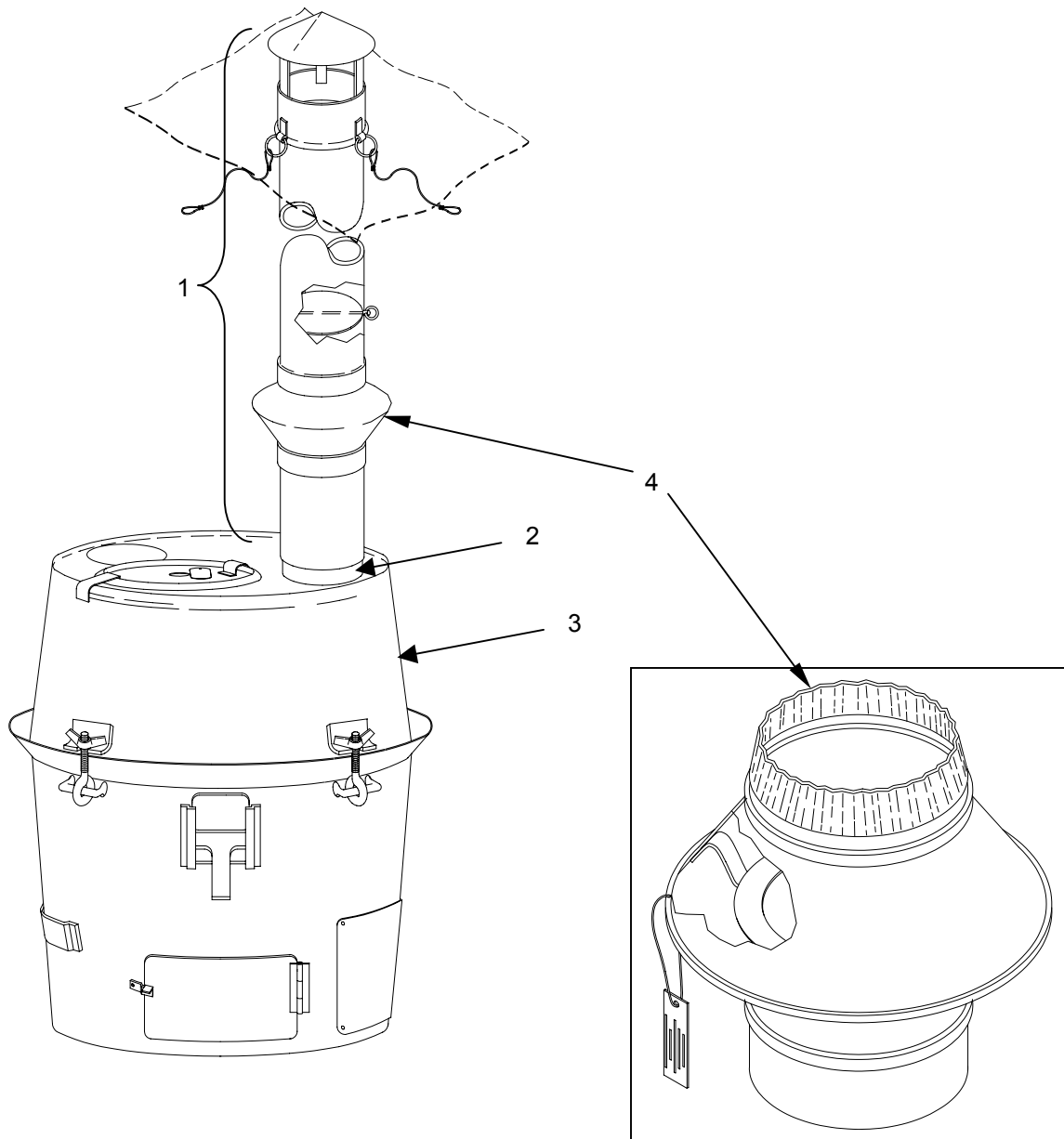

END OF WORK PACKAGE

**OPERATOR MAINTENANCE
H-45 LARGE RADIANT SPACE HEATER
(TYPE I, SOLID FUEL)
NSN 4520-01-354-1191
(TYPE II, LIQUID FUEL)
NSN 4520-01-329-3451
STACK PIPE ASSEMBLY
INSPECT, SERVICE, REPLACE**

INITIAL SETUP:**Materials**

Brush (WP 0052 00, Table 1, Item 3)
Rags (WP 0052 00, Table 1, Item 7)

Equipment Condition

H-45 shutdown and cool (WP 0005 00)
Guy lines anchoring stack pipe untied from
stakes (WP 0005 00)

Personnel Required

One

H-45 TYPE I (SOLID FUEL) AND TYPE II (LIQUID FUEL) HEATERS**REMOVE**

1. Remove the stack pipe assembly **(1)** from the stack flange **(2)** on the top heater shell **(3)**.
2. Remove the stack cap assembly **(4)** from the stack pipe assembly **(1)**.
3. Disassemble the stack pipe assembly **(1)**.

INSPECT

Inspect the six stack pipe sections for holes, loose fitting joints, distortions, and soot.

SERVICE

Clean any soot and carbon deposits from the pipe sections using rags or brushes.

REPLACE

If damaged, replace the stack pipe assembly **(1)**.

INSTALL (REFER TO WP 0005 00)

1. Reassemble the stack pipes.
2. Install the stack pipe assembly **(1)** on the flange **(2)** on the top heater shell **(3)**.

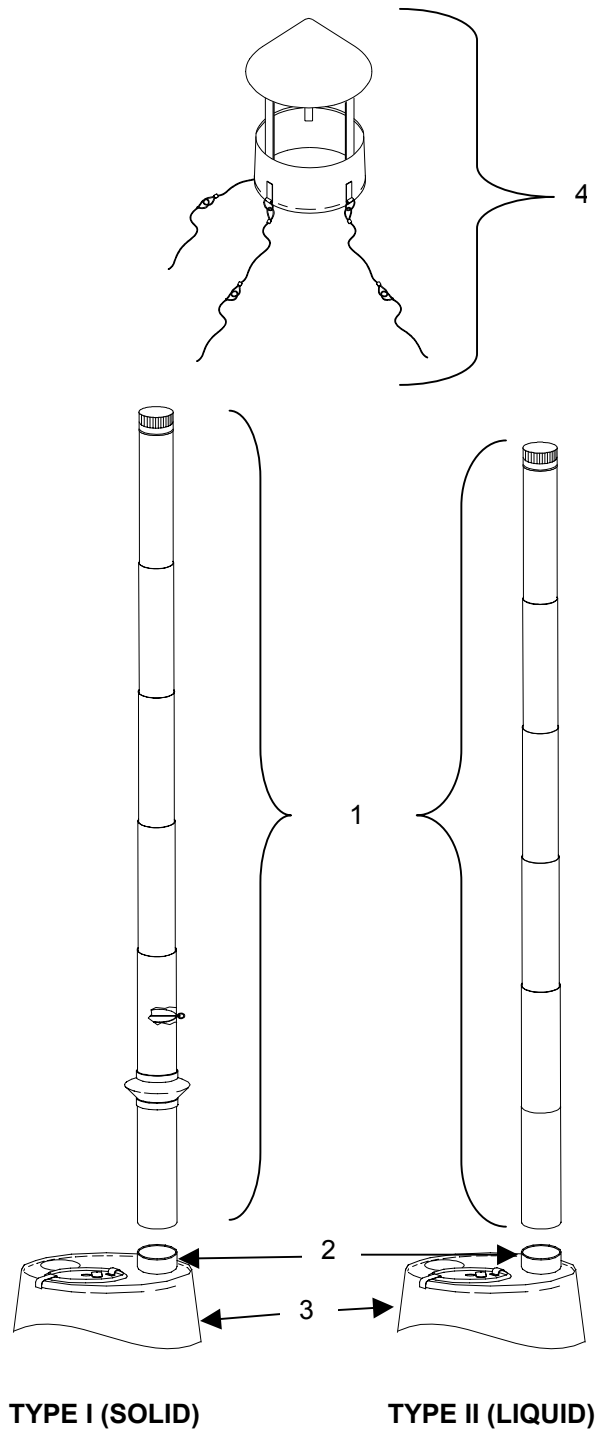

END OF WORK PACKAGE

**OPERATOR MAINTENANCE
H-45 LARGE RADIANT SPACE HEATER
(TYPE II, LIQUID FUEL)
NSN 4520-01-329-3451
BURNER SHELL AND BURNER CAP ASSEMBLIES
INSPECT, SERVICE, REPLACE**

INITIAL SETUP:**Materials**

Absorbent Material (WP 0052 00, Table 1, Item 1)
Brush (WP 0052 00, Table 1, Item 3)
Rags (WP 0052 00, Table 1, Item 7)

Equipment Condition

H-45 shutdown and cool (WP 0005 00)
Guy lines anchoring stack pipe untied from
stakes (WP 0005 00)

Personnel Required

One

H-45 TYPE II (LIQUID FUEL) HEATER**REMOVE**

1. Remove the fuel can **(1)** from the fuel can stand **(2)**, and place the fuel can **(1)** upright on the ground.
2. Remove the stack pipe assembly **(3)** from the stack flange **(4)** on the top heater shell **(5)**.
3. Place a petroleum absorbent pad under the fuel flow control valve **(6)**, and disconnect the female QD fitting **(7)** on the flow control burner hose **(8)** from the flow control burner male QD fitting **(9)** on the fuel flow control valve **(6)**.
4. Loosen the wing nuts on the bolt and wing nut assemblies **(10)** holding the top heater shell **(5)** to the heater body base **(11)**, remove the bolt and wing nut assemblies **(10)** from the brackets **(12)**, and remove the top heater shell **(5)**.
5. Remove the burner shell assembly **(13)** from the heater body base **(11)**.
6. Remove the burner cap assembly **(14)** from the burner shell assembly **(13)**.
7. Remove the superheater assembly **(15)** from the burner shell assembly **(13)**.

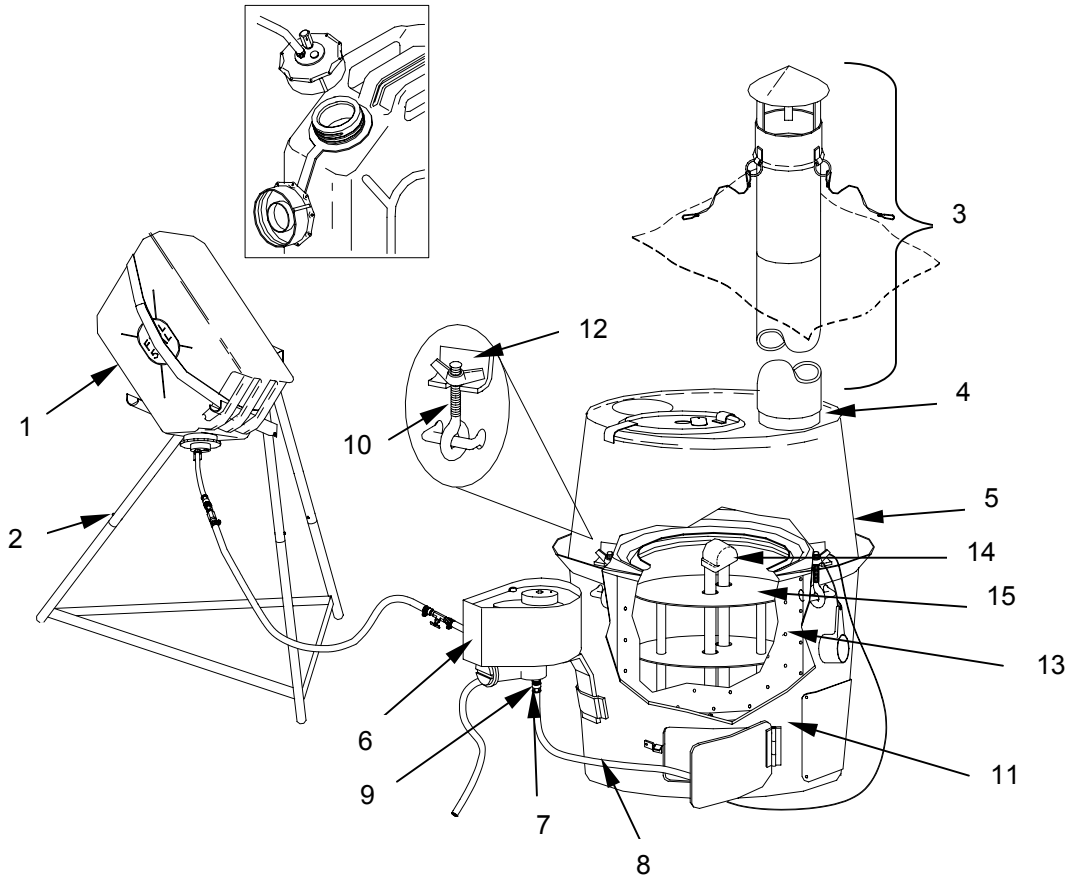

INSPECT

1. Inspect the burner shell assembly **(3)** for carbon buildup, distortions, warping of metal, or other damage. Notify unit maintenance if the burner shell assembly **(3)** is damaged.
2. Inspect the perforations **(5)** in the wall of the burner shell assembly **(3)** for carbon or soot buildup that obstructs airflow.
3. Inspect the burner base up tube **(6)** and the interior of the burner cap assembly **(12)** for carbon or soot buildup.

SERVICE**CAUTION**

Do not enlarge perforations in the burner shell assembly when cleaning. Increased airflow will degrade burner performance.

CAUTION

Be sure to drain any fuel that may remain in the up tube after removing the burner shell assembly.

1. Clean the burner shell assembly **(3)** as necessary to remove carbon and soot buildup.
2. Clean perforations **(5)** in the burner shell assembly **(3)** with a stiff bristle brush.
3. Clean the burner base up tube **(6)** and the interior of the burner cap assembly **(12)** with the burner reaming tool **(7)** by moving the tool **(7)** in and out of the up tube **(6)** and burner cap assembly **(12)** while twisting the tool **(7)**.
4. Turn the burner shell assembly **(3)** upside down to empty the scraped off carbon.

REPLACE

1. Replace the burner shell assembly **(3)** if damaged.
2. Replace the burner cap assembly **(12)** if damaged.

INSTALL

1. Place the burner shell assembly **(3)** inside the heater body base **(4)** and position the burner shell assembly **(3)** so that the pipe nipple **(8)** protrudes through the door opening **(9)** next to the fuel flow control bracket **(10)**.
2. Connect the flow control burner hose assembly **(1)** to the fuel flow control valve **(2)**.
3. Install the superheater assembly **(11)**.
4. Install the burner cap assembly **(12)**.

5. Install the top heater shell (refer to WP 0005 00).
6. Install the stack pipe assembly on the stack flange on the top heater shell (refer to WP 0005 00).

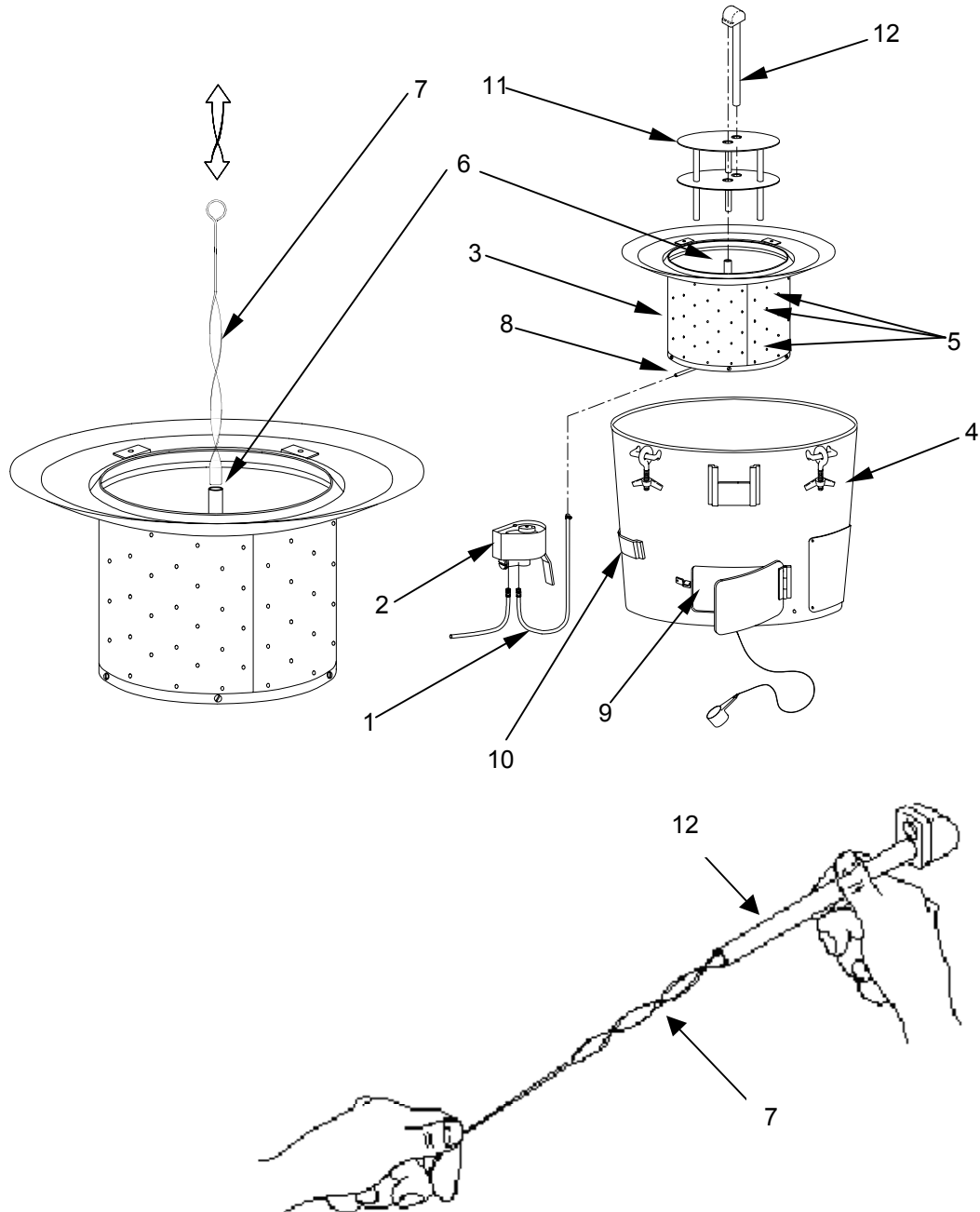

END OF WORK PACKAGE

**OPERATOR MAINTENANCE
H-45 LARGE RADIANT SPACE HEATER
(TYPE II, LIQUID FUEL)
NSN 4520-01-329-3451
SUPERHEATER ASSEMBLY
INSPECT, SERVICE, REPLACE**

INITIAL SETUP:**Materials**

Absorbent Material (WP 0052 00, Table 1, Item 1)
Brush (WP 0052 00, Table 1, Item 3)
Rags (WP 0052 00, Table 1, Item 7)

Equipment Condition

H-45 shutdown and cool (WP 0005 00)
Guy lines anchoring stack pipe untied from
stakes (WP 0005 00)

Personnel Required

One

H-45 TYPE II (LIQUID FUEL) HEATER**REMOVE**

1. Remove the fuel can (1) from the fuel can stand (2), and place the fuel can (1) upright on the ground.
2. Remove the stack pipe assembly (3) from the stack flange (4) on the top heater shell (5).
3. Place an absorbent pad under the fuel flow control valve (6), and disconnect the female QD fitting (7) on the flow control burner hose (8) from the flow control burner male QD fitting (9) on the fuel flow control valve (6).
4. Loosen the wing nuts on the bolt and wing nut assemblies (10) holding the top heater shell (5) to the heater body base (11), remove the bolt and wing nut assemblies (10) from the brackets (12), and remove the top heater shell (5).
5. Remove the burner shell assembly (13) from the heater body base (11).
6. Remove the burner cap assembly (14) from the burner shell assembly (13).
7. Remove the superheater assembly (2) from burner shell assembly (3).

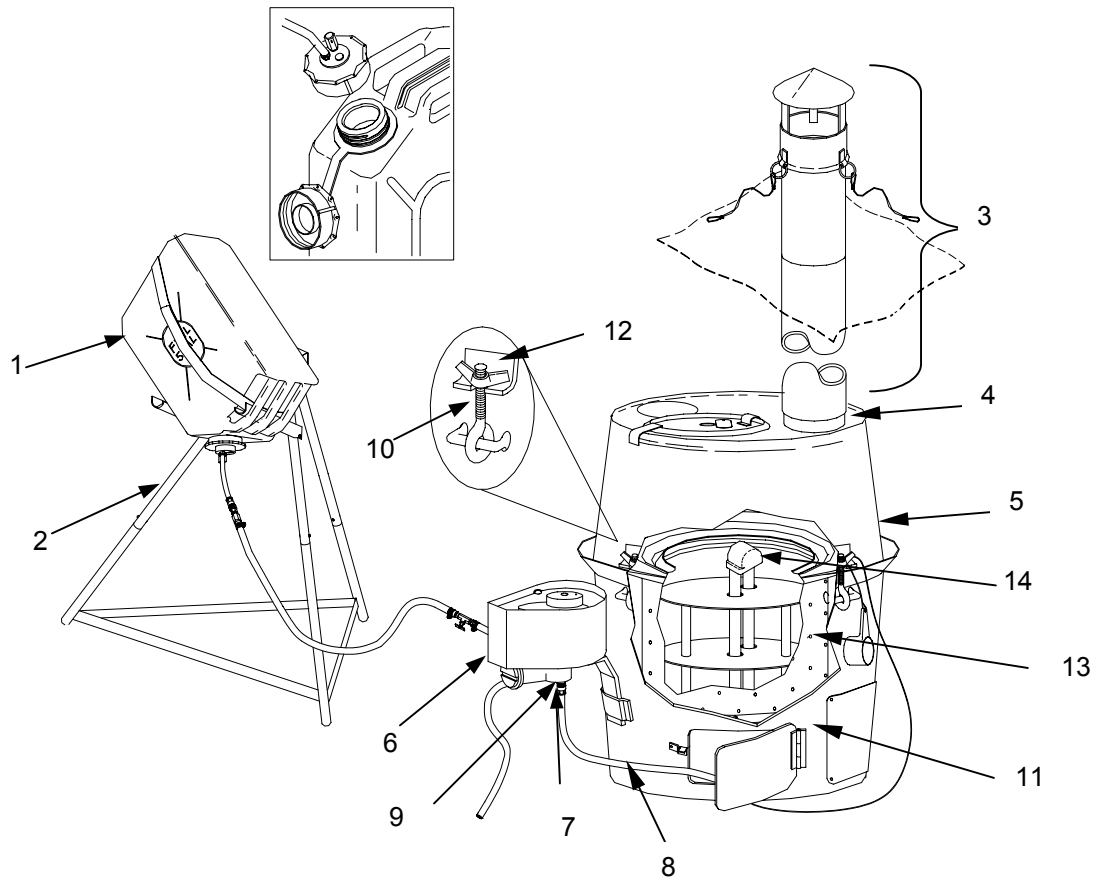

INSPECT

Inspect the superheater assembly (2) for carbon buildup, distortions, warping of metal, or other damage.

SERVICE

Clean the superheater assembly (2) as necessary to remove carbon and soot buildup.

REPLACE

Replace the super heater assembly (2) if it is damaged.

INSTALL

1. Install the superheater assembly (2) in the burner shell assembly (3).
2. Install the burner cap assembly (1).
3. Install the burner shell assembly (3).
4. Install the top heater shell assembly (refer to WP 0005 00).
5. Install the stack pipe assembly on the stack flange on the top heater shell (refer to WP 0005 00).

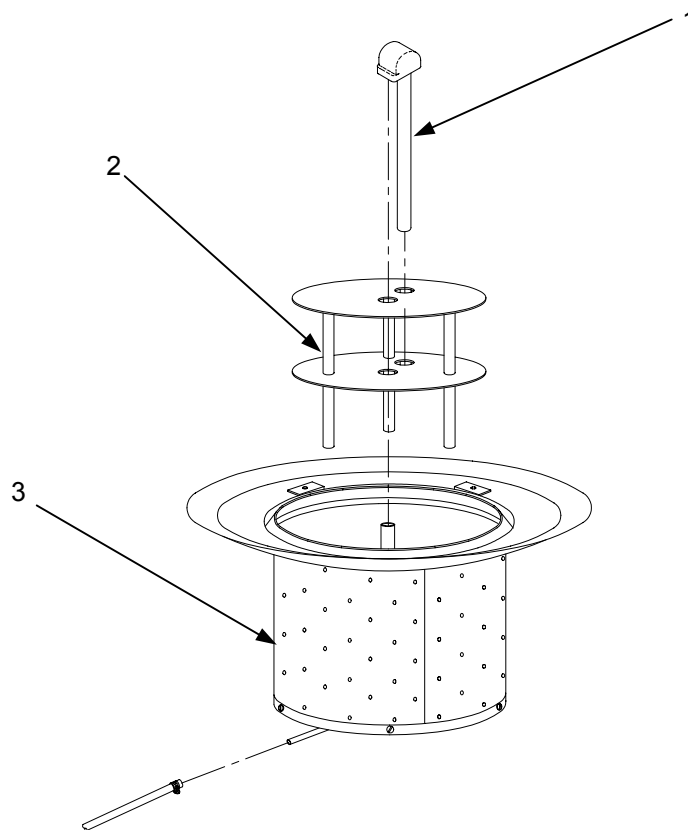

END OF WORK PACKAGE

THIS PAGE INTENTIONALLY LEFT BLANK

**OPERATOR MAINTENANCE
H-45 LARGE RADIANT SPACE HEATER
(TYPE II, LIQUID FUEL)
NSN 4520-01-329-3451
HOSE ASSEMBLIES
INSPECT, REPLACE**

INITIAL SETUP:**Materials/Parts**

Absorbent Material (WP 0052 00, Table 1, Item 1)

References

WP 0005 00

Personnel Required

One

Equipment Condition

H-45 shutdown and cool (WP 0005 00)

H-45 TYPE II (LIQUID FUEL) HEATER**INSPECT****1. Fuel Supply Hose**

- a. Inspect the fuel supply hose **(1)** for any cracking or other deterioration that would cause the hose to leak.
- b. Check the condition of all connections **(2)** between the hose and the fittings **(3)** for a secure seal.

2. Fuel Overflow Hose

- a. Inspect the overflow hose **(4)** for any cracking or other deterioration that would cause the hose to leak.
- b. Check the condition of the connection **(5)** between the hose and the quick disconnect fitting **(6)** for a secure seal.

3. Flow Control Burner Hose

- a. Inspect the flow control burner hose **(7)** for any cracking or other deterioration that would cause the hose to leak.
- b. Check the condition of the connections **(8)** between the hose and the fittings **(9)** for a secure seal.
- c. If there are any cuts or damage that would cause the hose to leak, or if any of the fittings are damaged, contact unit maintenance.

REPLACE

1. **Fuel Supply Hose.** Replace the fuel supply hose (1) if there are any cuts or damage to the hose or the fittings that would cause the hose to leak.
2. **Fuel Overflow Hose.** Replace the fuel overflow hose (4) if there are any cuts or damage to the hose or the fittings that would cause the hose to leak.

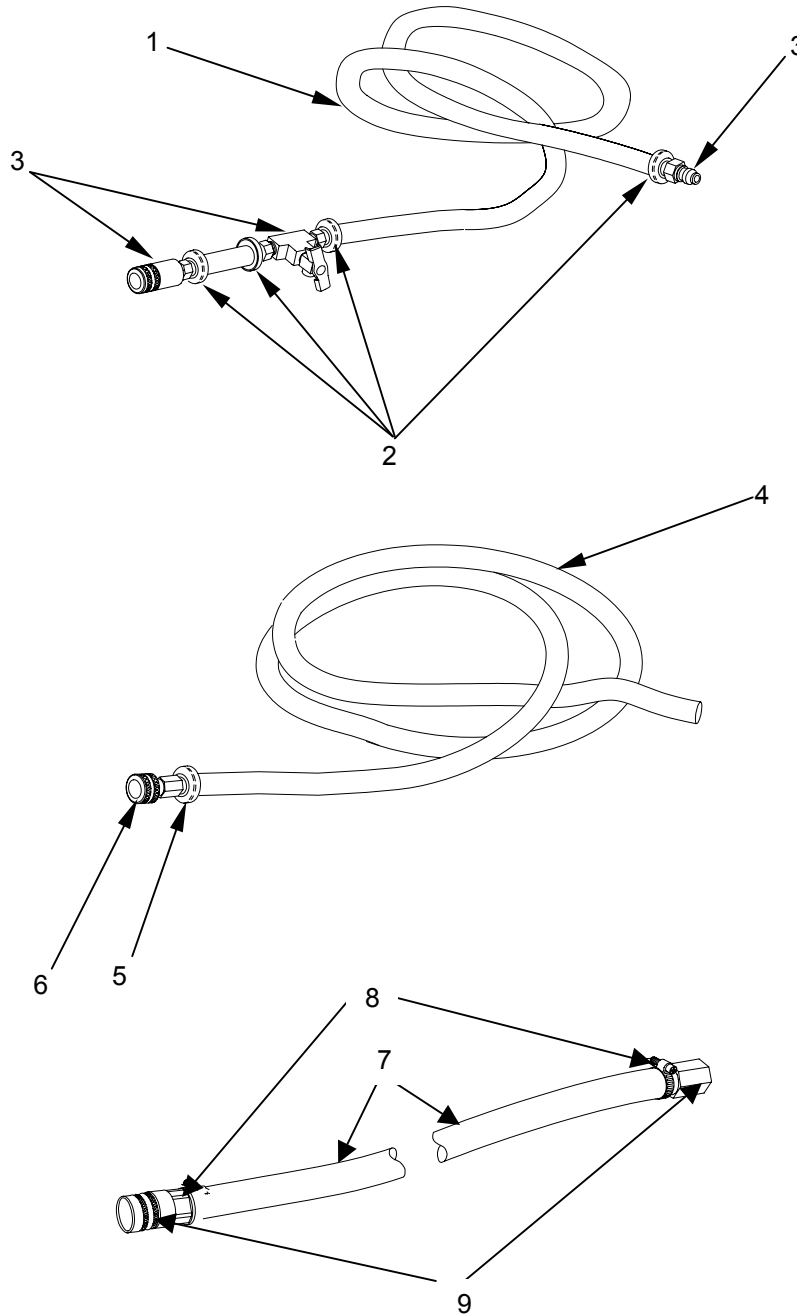
**END OF WORK PACKAGE**

**OPERATOR MAINTENANCE
H-45 LARGE RADIANT SPACE HEATER
(TYPE II, LIQUID FUEL)
NSN 4520-01-329-3451
HIGH FIRE RING
INSPECT**

INITIAL SETUP:**Materials**

Absorbent Material (WP 0052 00, Table 1, Item 1)

Equipment Condition

H-45 shutdown and cool (WP 0005 00)

Guy lines anchoring stack pipe untied from stakes (WP 0005 00)

Personnel Required

One

References

WP 0005 00

H-45 TYPE II (LIQUID FUEL) HEATER**REMOVE**

1. Remove the fuel can **(1)** from the fuel can stand **(2)**, and place the fuel can **(1)** upright on the ground.
2. Remove the stack pipe assembly **(3)** from the stack flange **(4)** on the top heater shell **(5)**.
3. Place an absorbent pad under the fuel flow control valve **(6)**, and disconnect the female QD fitting **(7)** on the flow control burner hose **(8)** from the flow control burner male QD fitting **(9)** on the fuel flow control valve **(6)**.
4. Loosen the wing nuts on the bolt and wing nut assemblies **(10)** holding the top heater shell **(5)** to the heater body base **(11)**, remove the bolt and wing nut assemblies **(10)** from the brackets **(12)**, and remove the top heater shell **(5)**.
5. Remove the burner shell assembly **(13)** from the heater body base **(11)**.

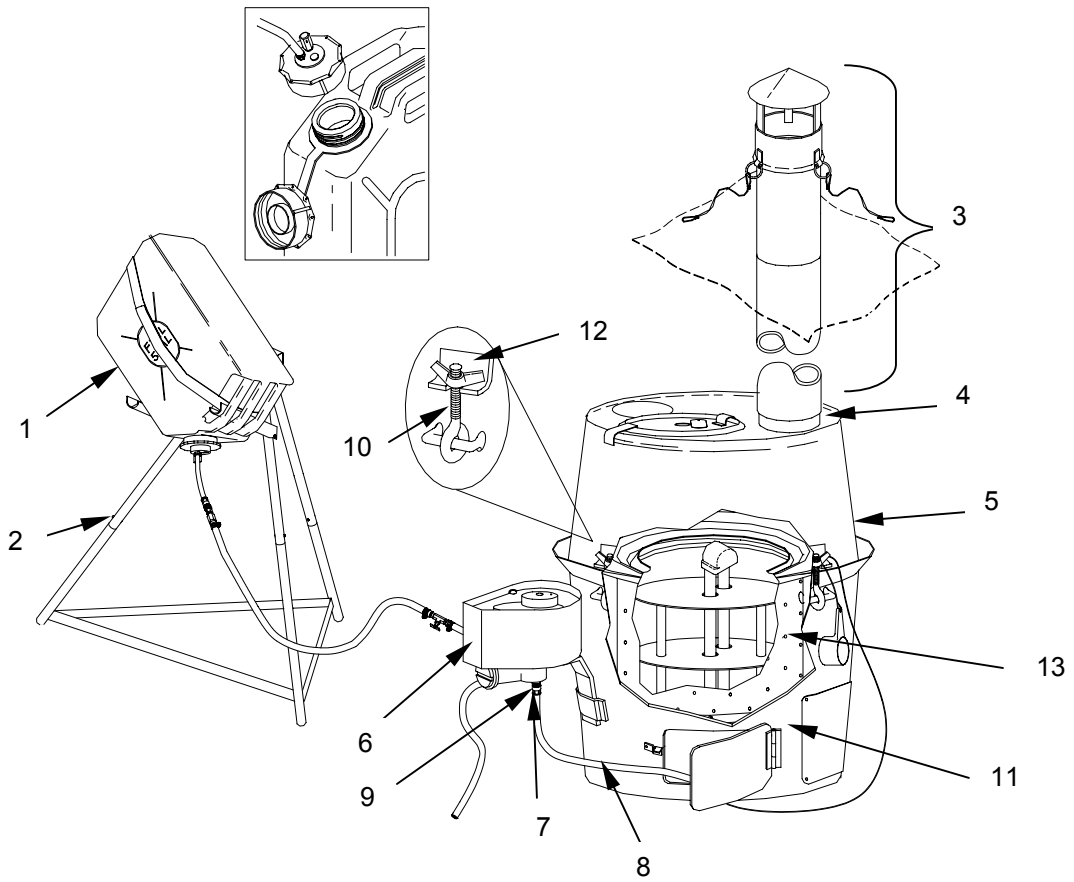

INSPECT

The high fire ring (2) must be inspected in place since the screws that secure the clamps (1) are installed in mild steel and are extremely difficult to remove after the heater has been used. The high fire ring (2) snaps into a groove and can be damaged when attempting removal. Examine the high fire ring (2) and clamps (1) for bends, dents, corrosion, poor seating, and general condition. If the high fire ring is dented or bent beyond repair, contact unit maintenance.

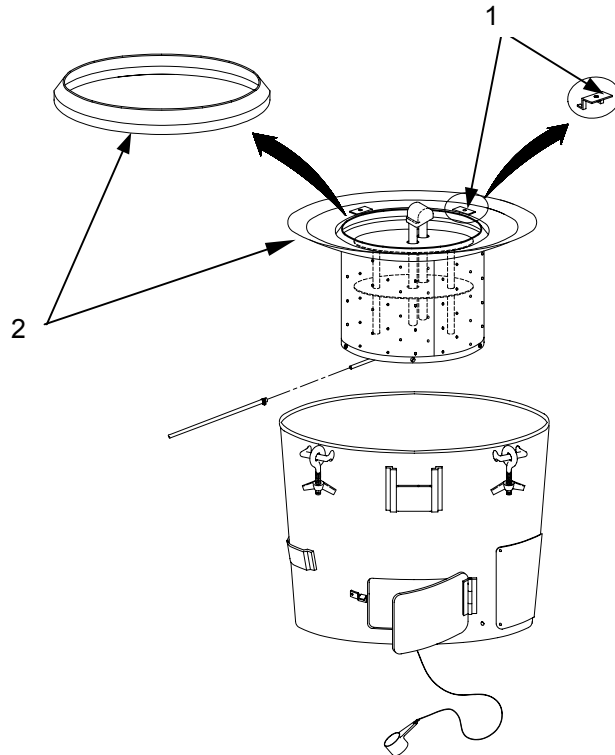
**INSTALL (REFER TO WP 0005 00)**

1. Place the burner shell assembly inside the heater body base and position the burner shell assembly so that the pipe nipple protrudes through the door opening next to the fuel flow control bracket.
2. Connect the flow control burner hose assembly to the fuel flow control valve.
3. Install the superheater assembly.
4. Install the burner cap assembly.
5. Install the top heater shell.
6. Install the stack pipe assembly on the stack flange on the top heater shell.

END OF WORK PACKAGE

THIS PAGE INTENTIONALLY LEFT BLANK

**OPERATOR MAINTENANCE
H-45 LARGE RADIANT SPACE HEATER
(TYPE II, LIQUID FUEL)
NSN 4520-01-329-3451
CUP AND CABLE ASSEMBLY
INSPECT**

INITIAL SETUP:
Personnel Required
One

Equipment Condition
H-45 shutdown and cool (WP 0005 00)

INSPECT

Inspect the cup and cable assembly (1) for damaged cup (2) or cable (3) and missing or loose fasteners (4). Contact unit maintenance if any parts are damaged.

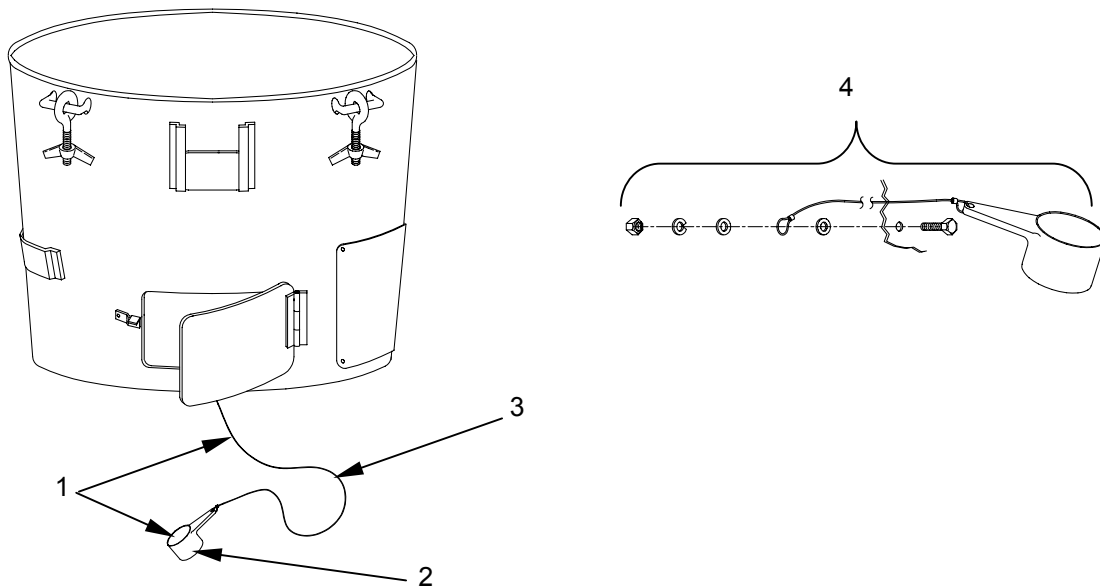

END OF WORK PACKAGE

THIS PAGE INTENTIONALLY LEFT BLANK

**OPERATOR MAINTENANCE
H-45 LARGE RADIANT SPACE HEATER
(TYPE II, LIQUID FUEL)
NSN 4520-01-329-3451
FUEL FLOW CONTROL VALVE
INSPECT, SERVICE**

INITIAL SETUP:**Materials/Parts**

Absorbent Material (WP 0052 00, Table 1, Item 1)
Rags (WP 0052 00, Table 1, Item 7)

References

WP 0005 00

Personnel Required

One

Equipment Condition

H-45 shutdown and cool (WP 0005 00)

H-45 TYPE II (LIQUID FUEL) HEATER**REMOVE**

1. Outside the tent, remove the fuel can from the fuel can stand assembly, and place the fuel can upright on level ground. (Refer to WP 0005 00).

NOTE

The fuel flow control inlet fitting **(5)** is the fitting that sticks out of the left side of the fuel flow control valve **(1)** closest to the heater body base **(11)** when the fuel flow control valve **(1)** is mounted on the bracket holder **(10)** on the heater body base **(11)**.

The fuel overflow fitting **(7)** is the fitting that sticks out of the left side of the fuel flow control valve **(1)** furthest from the heater body base **(11)** when the fuel flow control valve **(1)** is mounted on the bracket holder **(10)** on the heater body base **(11)**.

The flow control outlet fitting **(9)** is the only fitting on the bottom of the fuel flow control valve **(1)** when the fuel flow control valve **(1)** is mounted on the bracket holder **(10)** on the heater body base **(11)**.

2. Inside the tent, place a piece of absorbent material under the fuel flow control valve **(1)**, and turn the fuel OFF/ON control **(3)** on the fuel flow control valve **(1)** to OFF.
3. Disconnect the fuel supply hose **(4)** from the fuel flow control inlet fitting **(5)**.
4. Disconnect the fuel overflow hose **(6)** from the fuel overflow fitting **(7)**.
5. Disconnect the flow control burner hose **(8)** from fuel flow control outlet fitting **(9)**.
6. Remove the fuel flow control valve **(1)** from the bracket holder **(10)** on the heater body base **(11)**.

INSPECT

Inspect the fuel flow control valve **(1)** and control dials **(2,3)** for damage, obliterated markings, or evidence of leaking. If the fuel flow control valve **(1)** is leaking or damaged, contact unit maintenance.

SERVICE

Clean the control dials **(2,3)** on the fuel flow control valve **(1)** if necessary. Use a soft cloth to prevent scratches.

INSTALL

1. Install the fuel flow control valve **(1)** in the bracket holder **(10)** on the heater body base **(11)**.
2. Attach the flow control burner hose **(8)** to the fuel flow control outlet fitting **(9)**.
3. Attach the fuel overflow hose **(6)** to the fuel overflow fitting **(7)**.
4. Attach the fuel supply hose **(4)** to fuel supply inlet fitting **(5)**.
5. Place the fuel can upside down on the fuel can stand assembly. (Refer to WP 0005 00.) Make sure all connections are tight and there are no fuel leaks.
6. Turn the fuel OFF/ON control **(3)** on the fuel flow control valve **(1)** to ON.
7. Check for leaks.
8. Dispose of the absorbent material in accordance with the local Material Safety Data Sheet (MSDS) procedure.

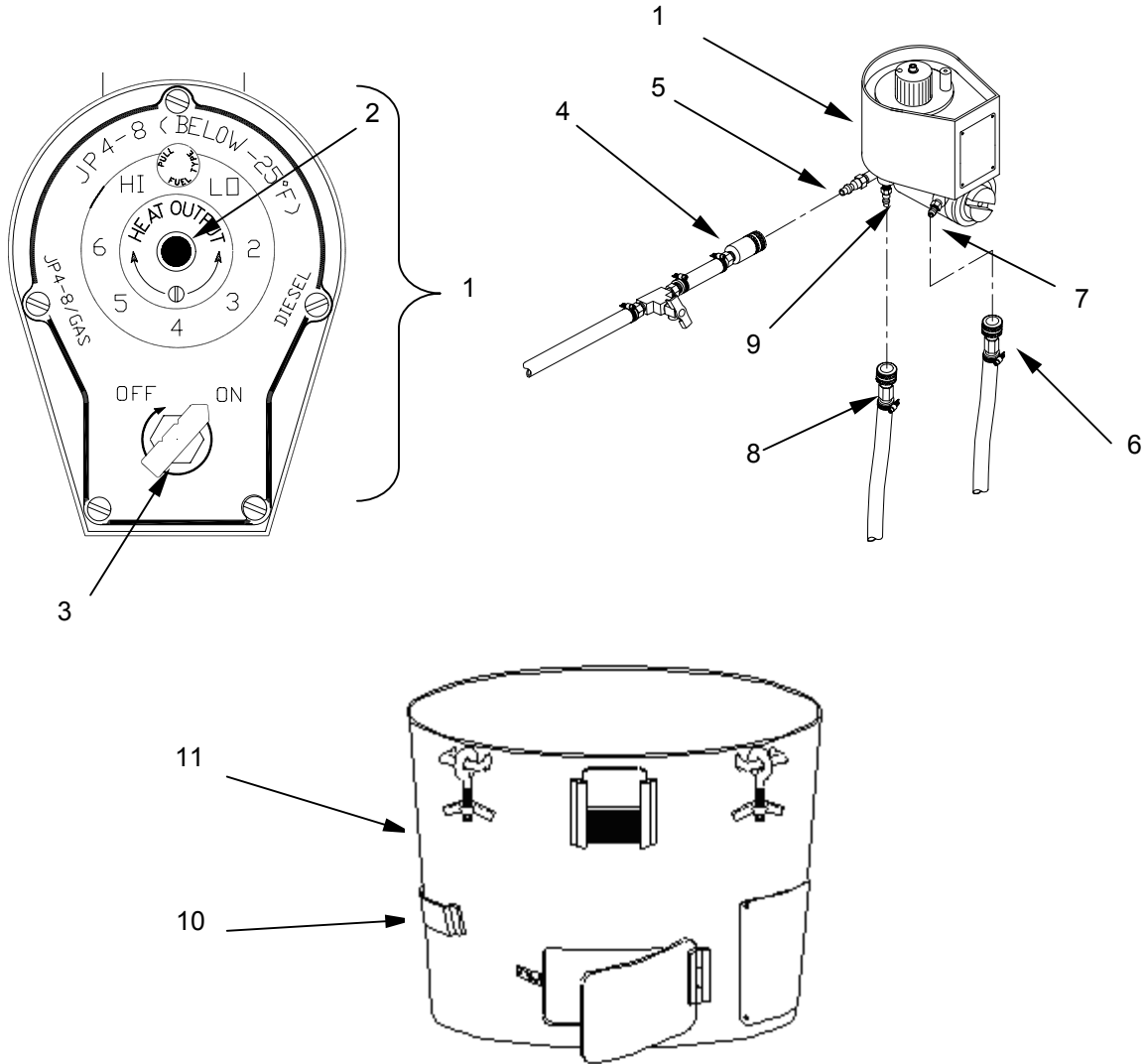

END OF WORK PACKAGE

THIS PAGE INTENTIONALLY LEFT BLANK

**OPERATOR MAINTENANCE
H-45 LARGE RADIANT SPACE HEATER
(TYPE II, LIQUID FUEL)
NSN 4520-01-329-3451
GRAVITY FEED ADAPTER
INSPECT, REPLACE**

INITIAL SETUP:**Materials**

Absorbent Material (WP 0052 00, Table 1, Item 1)
Gasket (WP 0052 00, Table 1, Item 4)
Umbrella Valve (WP 0052 00, Table 1, Item 8)

References

WP 0005 00

Equipment Condition

H-45 shutdown and cool (WP 0005 00)

Personnel Required

One

H-45 TYPE II (LIQUID FUEL) HEATER**REMOVE (REFER TO WP 0005 00)**

1. Inside the tent, set the fuel OFF/ON control on the fuel flow control valve on the H-45 Type II (Liquid Fuel) Heater to the OFF position.
2. Outside the tent, place an absorbent mat close to the fuel can stand. Remove the fuel can from the fuel can stand, and place the fuel can upright on the absorbent mat.
3. Remove the fuel supply hose from the gravity feed adapter (see WP 0005 00).
4. Unscrew the gravity feed adapter cap from the fuel can.

INSPECT

1. Inspect the gravity feed adapter cap **(1)** for any cracks that would cause a fuel leak.
2. Inspect the gasket **(2)** inside the adapter for any cracks that would prevent a proper seal.
3. Inspect the hose **(3)** and QD connector **(4)** at the top of the adapter to ensure that they are securely connected and that the hoses are not cracked or otherwise damaged.
4. Check the holes **(5)** on the outside surface of the automatic vent **(6)** and insure that they are not blocked or clogged with dirt or other debris.
5. Check the holes **(7)** on the underside of the adapter and ensure that they are not clogged or blocked with any type of obstruction.
6. Inspect the condition of the umbrella valve **(8)** on the underside of the adapter. Make sure that the umbrella valve is not torn, cracked, worn or otherwise damaged that would prevent a good seal.

REPLACE

1. Replace a cracked or otherwise damaged gravity feed adapter gasket (2) by removing the damaged gasket and pressing a new gasket in place.
2. Replace a damaged umbrella valve (8) by first removing any remaining portions of the damaged valve. Pry off the protective cap (9) on the top of the adapter. Take the spare umbrella valve (10) out of its storage area. Press the spare umbrella valve (10) in place on the underside of the automatic vent (6). Be sure that the spare umbrella valve (10) is properly seated and that the edges of the valve are flush against the automatic vent (6).
3. Replace the gravity feed adapter if there are cracks in the plastic cap (1), the hose (3) is damaged, or the QD connector (4) leaks.

INSTALL (REFER TO WP 0005 00)

1. Screw the gravity feed adapter cap on the fuel can.
2. Install the fuel supply hose on the gravity feed adapter.
3. Install the fuel can on the fuel can stand.

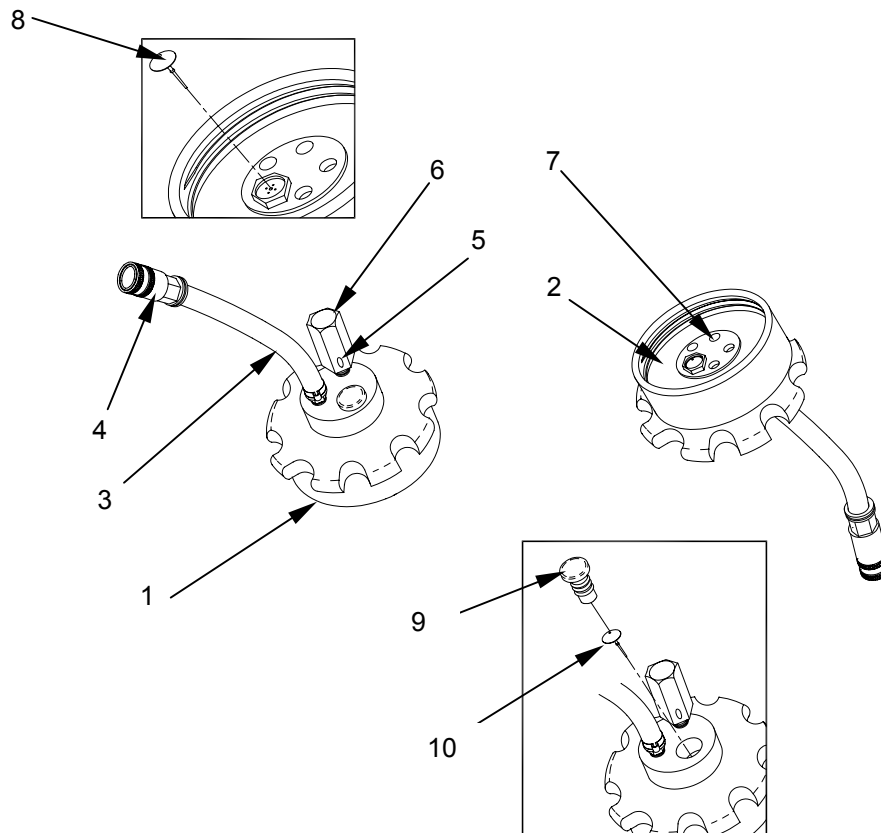
**END OF WORK PACKAGE**

CHAPTER 5

**UNIT MAINTENANCE INSTRUCTIONS
FOR THE
H-45 LARGE RADIANT SPACE HEATER**

THIS PAGE INTENTIONALLY LEFT BLANK

**UNIT MAINTENANCE
H-45 LARGE RADIANT SPACE HEATER
(TYPE I, SOLID FUEL)
NSN 4520-01-354-1191
(TYPE II, LIQUID FUEL)
NSN 4520-01-329-3451**

UNIT PREVENTIVE MAINTENANCE CHECK AND SERVICES (PMCS), INTRODUCTION

INTRODUCTION. Unit PMCS is performed quarterly. Record all defects found during the performance of PMCS and the steps taken to fix them on a DA Form 2404, Equipment Inspection and Maintenance Worksheet. Instructions for reporting and/or correcting noted deficiencies are contained in DA PAM 738-750.

UNIT PMCS PROCEDURES. The heater components must be inspected regularly to find and correct defects.

General. Table 1 in WP 0029 00 has been provided so you can keep your equipment in good operating condition and ready for its primary mission.

Warnings and cautions. Always observe the WARNINGS and CAUTIONS appearing in your PMCS table. Warnings and cautions appear before applicable procedures. You must observe these WARNINGS and CAUTIONS to prevent serious injury to yourself and others or to prevent your equipment from being damaged.

EXPLANATION OF TABLE ENTRIES

Item number column. Numbers in this column are for reference. When completing DA Form 2404 (Equipment Inspection and Maintenance Worksheet), include the item number for the check/ service indicating a fault. Item numbers also appear in the order that you must do checks and services for the intervals listed.

Interval column. This column tells you when you must do the procedure in the procedure column. BEFORE procedures must be done before you use or operate the equipment for its intended mission. DURING procedures must be done during the time you are operating or using the equipment for its intended mission. AFTER procedures must be done immediately after you have operated or used the equipment.

Location, check/ service column. This column lists the item that must be checked or serviced to know if the item is ready or available for its intended mission or for operation. You must check or service the item at the time stated in the interval column.

Procedure column. This column tells you the procedure you must follow to check or service the item listed in the check/ service column to know if the equipment is ready or available for its intended mission or for operation. You must do the procedure at the time stated in the interval column.

Not fully mission capable if column. Information in this column tells you what faults will keep your equipment from being capable of performing its primary mission. If you make check and service procedures that show faults listed in this column, do not operate the equipment. Follow standing operating procedures for maintaining the equipment or reporting equipment failure.

Other table entries. Be sure to observe all special information and notes that appear in your table.

END OF WORK PACKAGE

THIS PAGE INTENTIONALLY LEFT BLANK

**UNIT MAINTENANCE
H-45 LARGE RADIANT SPACE HEATER
(TYPE I, SOLID FUEL)
NSN 4520-01-354-1191
(TYPE II, LIQUID FUEL)
NSN 4520-01-329-3451**

UNIT PREVENTIVE MAINTENANCE CHECK AND SERVICES (PMCS), PROCEDURES

INITIAL SETUP:

Tools

General Mechanic's Tool Kit (WP 0041 00, Table 2, Item 1)

Personnel Required

One

Equipment Conditions

Heater shutdown and cool (WP 0005 00)

Materials

Absorbent Material (WP 0052 00, Table 1, Item 1)

Brush (WP 0052 00, Table 1, Item 3)

Lubricating Oil (WP 0052 00, Table 1, Item 5)

**Table 1. Unit Preventive Maintenance Checks and Services for H-45
Type I (Solid Fuel) and Type II (Liquid Fuel) Heaters**

Item No.	Interval	Item To Be Checked Or Serviced	Procedure	Equipment Not Ready/ Available If:
1	Quarterly	Strainer	Inspect strainer (1) for dirt, sediment, or other obstruction.	Strainer blocked

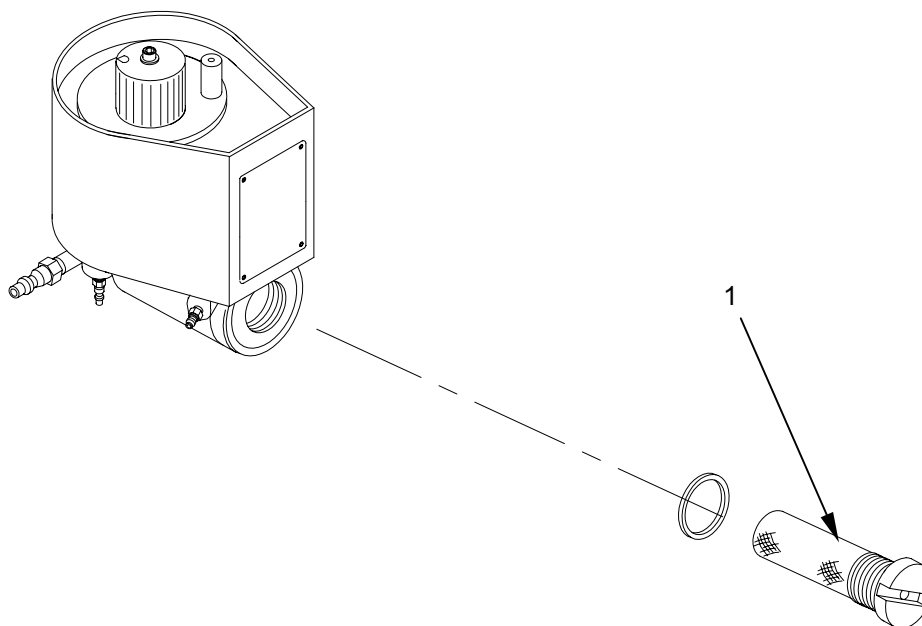

**Table 1. Unit Preventive Maintenance Checks and Services for H-45
Type I (Solid Fuel) and Type II (Liquid Fuel) Heaters - Continued**

Item No.	Interval	Item to be Checked or Serviced	Procedure	Equipment Not Ready/ Available If:
2	Quarterly	Burner Assembly	Inspect street elbow fitting (1) and reducer bushing (2) for soot buildup or fuel residue. Inspect pipe nipple (3) for crimping or bends that restrict fuel flow and soot buildup. Replace pipe nipple (3) as required.	Elbow is clogged Fuel flow is restricted.

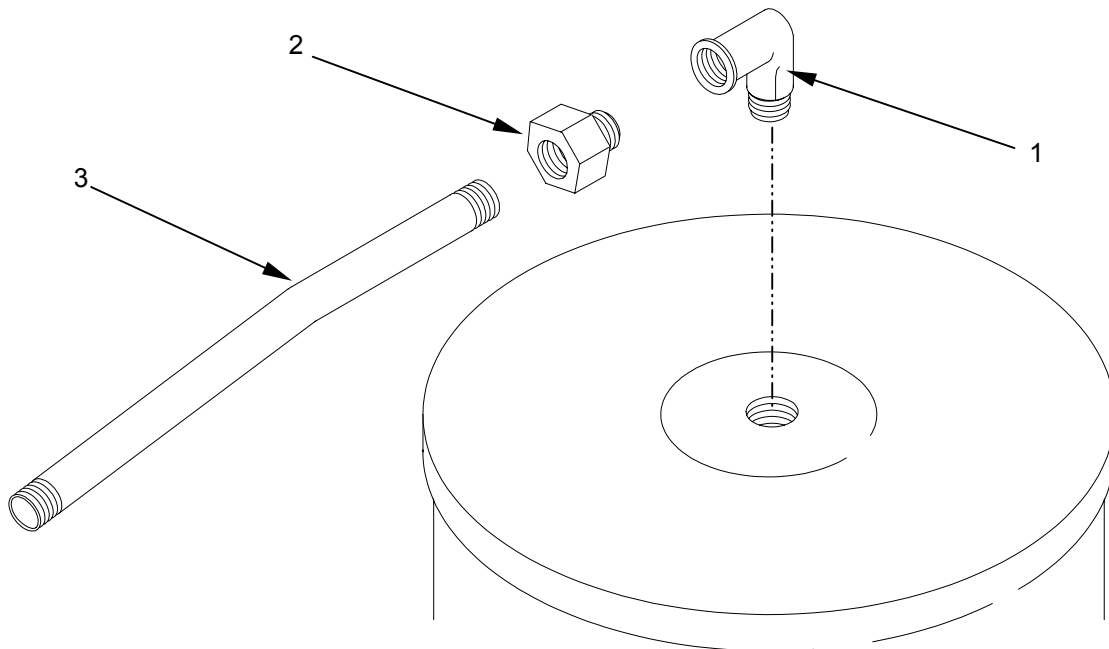

LUBRICATION REQUIREMENTS

The door hinge, door latch assembly, and sight glass cover should be lubricated with a light machine oil when stored.

END OF WORK PACKAGE

UNIT MAINTENANCE
H-45 LARGE RADIANT SPACE HEATER
 (TYPE I, SOLID FUEL)
 NSN 4520-01-354-1191
 (TYPE II, LIQUID FUEL)
 NSN 4520-01-329-3451
HEATER BODY BASE DOOR LATCHES
REPLACE

INITIAL SETUP:**Tools**

General Mechanic's Tool Kit (WP 0041 00,
Table 2, Item 1)

References

WP 0005 00

Personnel Required

One

Equipment Condition

H-45 shutdown and cool (WP 0005)

REMOVE

Open the heater base door (1) and, while holding the hexagon lock nut (2), unscrew and remove the screw (3) from the damaged door latch (4) on the heater body base (5).

REPLACE

Replace the damaged or missing door latch (4).

INSTALL

Install the door latch (4) by inserting the screw (3) through the latch (4), the heater body base (5), the spring washer (6), and the flat washer (7). Screw the hexagon lock nut (2) onto the end of the screw (3), and firmly tighten.

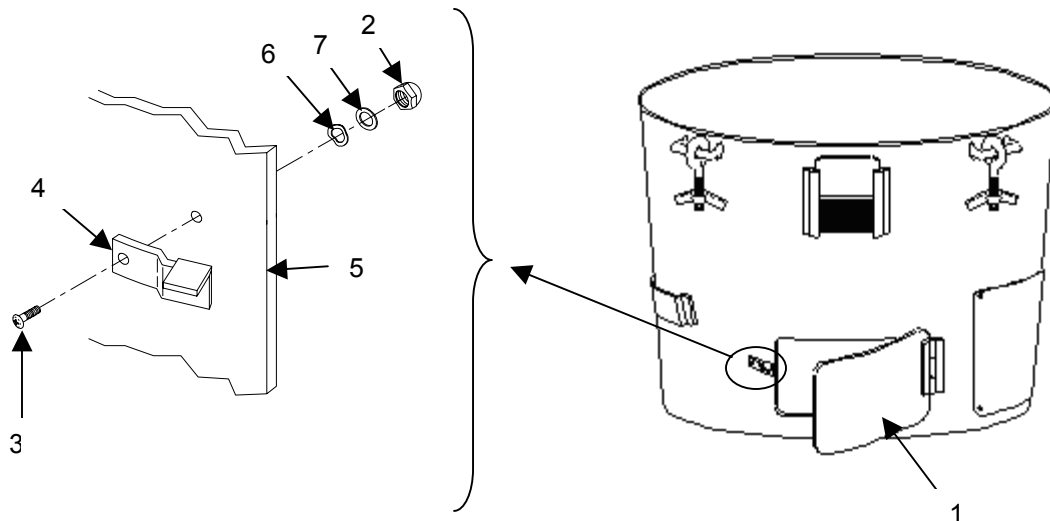

END OF WORK PACKAGE

THIS PAGE INTENTIONALLY LEFT BLANK

**UNIT MAINTENANCE
H-45 LARGE RADIANT SPACE HEATER
(TYPE I, SOLID FUEL)
NSN 4520-01-354-1191
ADAPTER RING
REPAIR**

INITIAL SETUP:**Tools**

General Mechanic's Tool Kit (WP 0041 00,
Table 2, Item 1)

References

WP 0005 00

Personnel Required

One

Equipment Conditions

Heater shutdown and cool (WP 0005 00)
Adapter ring removed (WP 0005 00)

H- 45 TYPE I (SOLID FUEL) HEATER**REPAIR**

Straighten deformations on adapter ring **(1)** to extent possible.

FOLLOW-ON MAINTENANCE:

Install adapter ring. (Refer to WP 0005 00.)

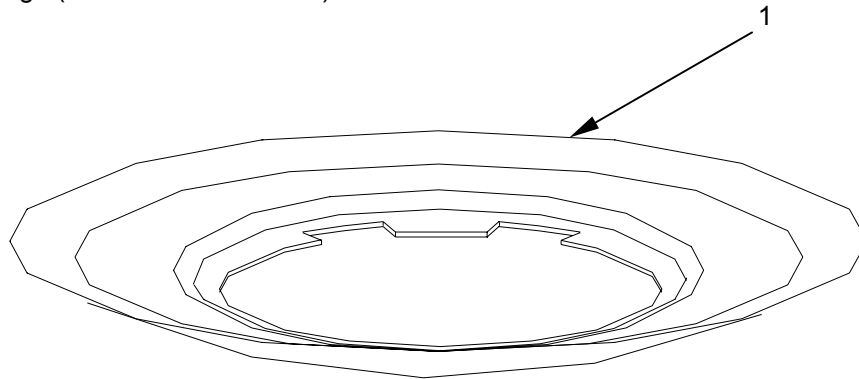

END OF WORK PACKAGE

THIS PAGE INTENTIONALLY LEFT BLANK

**UNIT MAINTENANCE
H-45 LARGE RADIANT SPACE HEATER
(TYPE I, SOLID FUEL)
NSN 4520-01-354-1191
GRATE ASSEMBLY
REPAIR**

INITIAL SETUP:**Tools**

General Mechanic's Tool Kit (WP 0041 00, Table 2, Item 1)

References

WP 0005 00

Materials/Parts

Cotter pin (WP 0043 00, Item 13)

Equipment Condition

Heater shut down and cool (refer to WP 0005 00)
Grates removed (refer to WP 0005 00)

Personnel Required

One

H-45 TYPE I (SOLID FUEL) HEATER**REMOVE**

Remove the cotter pin **(1)** securing the round grate **(2)** and draw grate **(3)** together.

REPAIR

1. Replace the damaged part or parts **(1, 2, 3, or a combination of those)**. If the entire grate assembly needs to be replaced, contact operator maintenance.
2. Align the round grate **(2)** over the draw grate **(3)** with the round grate **(2)** on top.
3. Insert the cotter pin **(1)** through the round grate **(2)** and draw grate **(3)**, and spread to secure.

INSTALL

Install the grate assembly **(1,2,3)**. (Refer to WP 0005 00.)

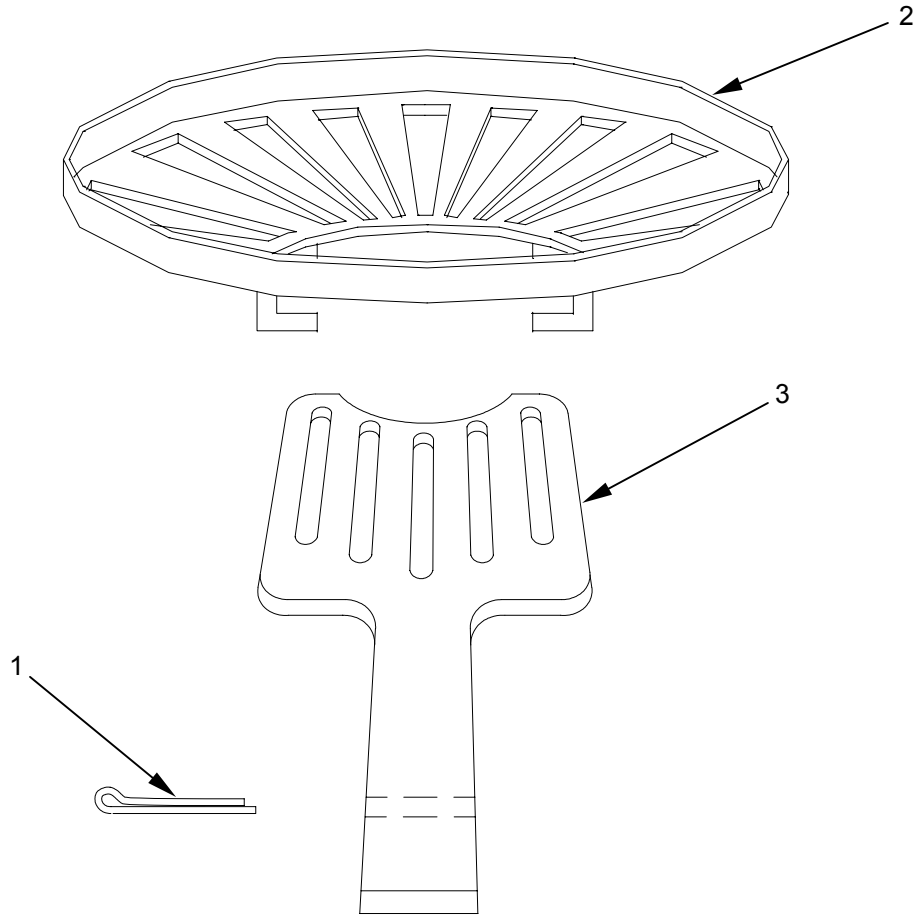

END OF WORK PACKAGE

UNIT MAINTENANCE
H-45 LARGE RADIANT SPACE HEATER
(TYPE I, SOLID FUEL)
NSN 4520-01-354-1191
(TYPE II, LIQUID FUEL)
NSN 4520-01-329-3451
STACK CAP ASSEMBLY
REPAIR

INITIAL SETUP :**Tools**

General Mechanic's Tool Kit (WP 0041 00,
Table 2, Item 1)

Reference

WP 0005 00

Personnel Required

One

Equipment Condition

Heater shut down and cool (WP 0005 00)
Stack cap assembly removed (WP 0005 00)

REPAIR

Using either the flat end of a hammer or a pair of pliers (as appropriate), straighten out bends, dents, and other deformities in the stack cap assembly **(1)**.

INSTALL

Install the stack cap assembly. (Refer to WP 0005 00.)

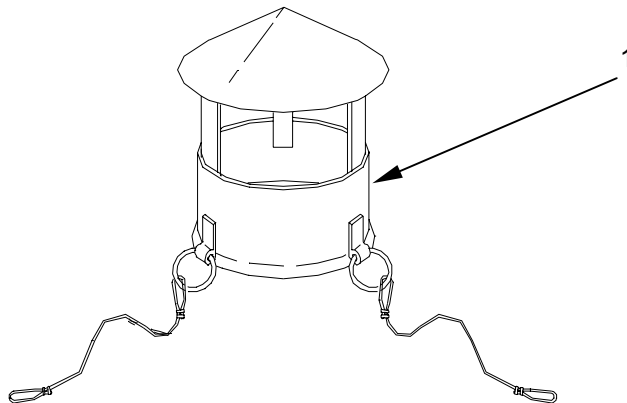

END OF WORK PACKAGE

THIS PAGE INTENTIONALLY LEFT BLANK

UNIT MAINTENANCE
H-45 LARGE RADIANT SPACE HEATER
(TYPE II, LIQUID FUEL)
NSN 4520-01-329-3451
HEATER BODY BASE
REPLACE

INITIAL SETUP:**Tools**

General Mechanic's Tool Kit (WP 0041 00, Table 2, Item 1)

References

WP 0005 00, WP 0014 00, WP 0021 00, WP 0038 00, WP 0052 00

Materials

Absorbent Material (WP 0052 00, Table 1, Item 1)

Equipment Condition

Heater shut down and cool (0050 00)
Top heater shell removed (WP 0014 00)
Burner shell assembly removed (WP 0021 00)

Personnel Required

One

H-45 TYPE II (LIQUID FUEL) HEATER**REMOVE**

1. Turn the OFF/ON control on the fuel flow control valve **(2)** to the OFF position.
2. Remove the fuel flow control valve **(2)** from the bracket support **(8)** on the heater body base **(3)** and set it aside on the absorbent pad.
3. Remove the cup/cable assembly **(4)**, and set aside. (Refer to WP 0038 00.)

REPLACE

Replace the heater body base **(3)**.

INSTALL

1. Install the cup/cable assembly **(4)** in the heater body base. (Refer to WP 0038 00.)
2. Place the burner shell assembly **(5)** inside the heater body base **(3)**, and position it so that the pipe nipple **(6)** faces the front base heater door opening **(7)** and so that the flow control burner hose protrudes through the door opening **(7)**. (Refer to WP 0021 00.)
3. Install the fuel flow control valve **(2)** into the bracket support **(8)** on the heater body base **(3)**.
4. Connect the flow control burner hose **(1)** to the fuel flow control valve **(2)**. And dispose of the petroleum absorbent mat in an authorized location.
5. Install the top heater shell. (Refer to WP 0014 00.)

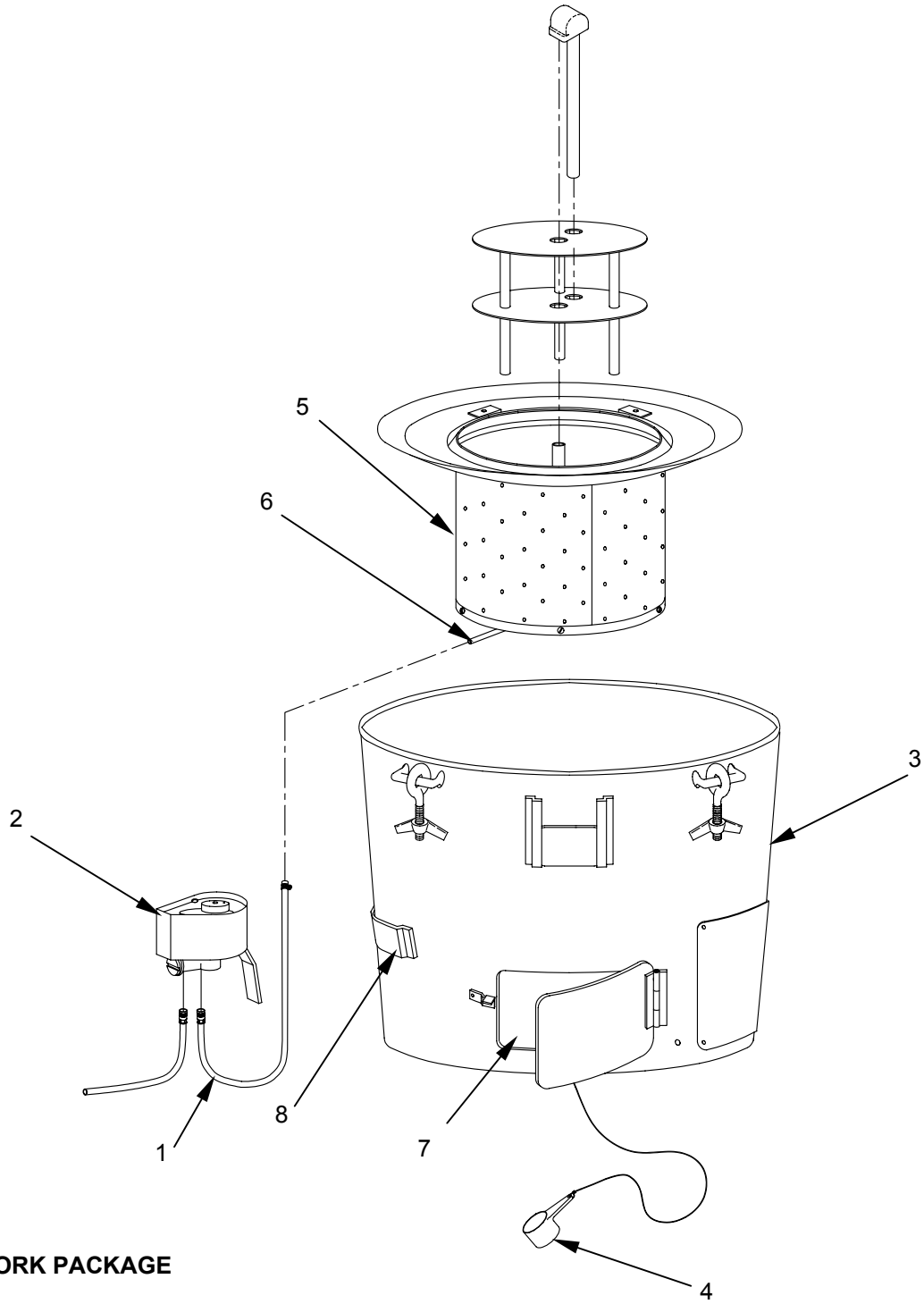

END OF WORK PACKAGE

**UNIT MAINTENANCE
H-45 LARGE RADIANT SPACE HEATER
(TYPE II, LIQUID FUEL)
NSN 4520-01-329-3451
BURNER SHELL ASSEMBLY
INSPECT, SERVICE, REPAIR**

INITIAL SETUP :**Tools**

General Mechanic's Tool Kit (WP 0041 00,
Table 2, Item 1)

References

WP 0005 00, WP 0014 00, WP 0022 00,
WP 0024 00, WP 0036 00

Materials/Parts

Absorbent Material (WP 0052 00, Table 1,
Item 1)
Pipe Thread Compound (WP 0052 00, Table 1,
Item 6)
Rags (WP 0052 00, Table 1, Item 7)

Equipment Condition

Heater shut down and cool (WP 0005 00)
Top heater shell removed (WP 0014 00)
Burner cap assembly removed (WP 0022 00)
Superheater assembly removed (WP 0022 00)
High fire ring removed (WP 0024 00)

Personnel Required

One

H-45 TYPE II (LIQUID FUEL) HEATER**REMOVE**

1. Turn the fuel OFF/ON control **(1)** on the fuel flow control valve **(2)** to the OFF position.
2. Place a petroleum absorbent mat under the fuel flow control valve.
3. Disconnect the flow control burner hose **(3)** from fuel flow control valve **(2)**.
4. Remove the fuel flow control valve **(2)** from the heater body base **(4)**, and place it on the petroleum absorbent mat.
5. Lift the burner shell assembly **(5)** vertically out of the heater body base **(4)**.
6. Remove the pipe nipple **(6)**.
7. Remove the reducer bushing **(7)**.
8. Remove the elbow fitting **(8)**.

INSPECT

1. Examine the inside of the elbow fitting **(8)** for dirt, soot, and fuel residue.
2. Examine the pipe nipple **(6)** and reducer bushing **(7)** for fuel sludge and deposits and for crimps or bends that restrict fuel flow.

SERVICE

WARNING



Clean fuel, used to clean parts, is potentially dangerous to personnel and property. Avoid repeated and prolonged skin contact. Do not use near open flame or excessive heat. Failure to do so may result in damage to skin and/or fire/explosion.

1. Clean dirty components by immersing them in or rinsing them with clean fuel.
2. Check for unrestricted fuel flow through the pipe nipple **(6)**, reducer bushing **(7)**, and elbow **(8)**.
3. From the bottom of the burner shell assembly **(5)**, push the burner reaming tool **(9)** through the underside of the burner up tube **(10)**.

REPAIR

1. Replace the flow control burner hose **(3)** if damaged. (Refer to WP 0036 00.)
2. Replace any damaged parts.

INSTALL

1. Apply a small amount of pipe thread sealant to the elbow fitting **(8)** threads, and install the elbow fitting **(8)**.
2. Apply a small amount of pipe thread sealant to the reducer bushing **(7)**, and install the reducer bushing **(7)**.
3. Apply a small amount of pipe thread sealant to the pipe nipple **(6)**, and install the pipe nipple **(6)**.
4. Install the flow control burner hose **(3)** on the pipe nipple **(6)**. (Refer to WP 0036 00.)
5. Place the burner shell assembly **(5)** inside the heater body base **(4)**, and position the burner shell assembly **(5)** with the pipe nipple **(6)** facing the front heater base door opening **(11)** so that the flow control burner hose **(3)** protrudes through the front heater base door opening **(11)**.
6. Connect the flow control-burner hose assembly **(3)** to the fuel flow control valve **(2)**, and dispose of the petroleum absorbent mat in an authorized location.
7. Install the fuel flow control valve **(2)** on the heater body base **(4)**.
8. Install the high fire ring. (Refer to WP 0024 00.)
9. Install the superheater assembly. (Refer to WP 0022 00.)

10. Install the burner cap assembly. (Refer to WP 0022.)

11. Install the top heater shell. (Refer to WP 0013.)

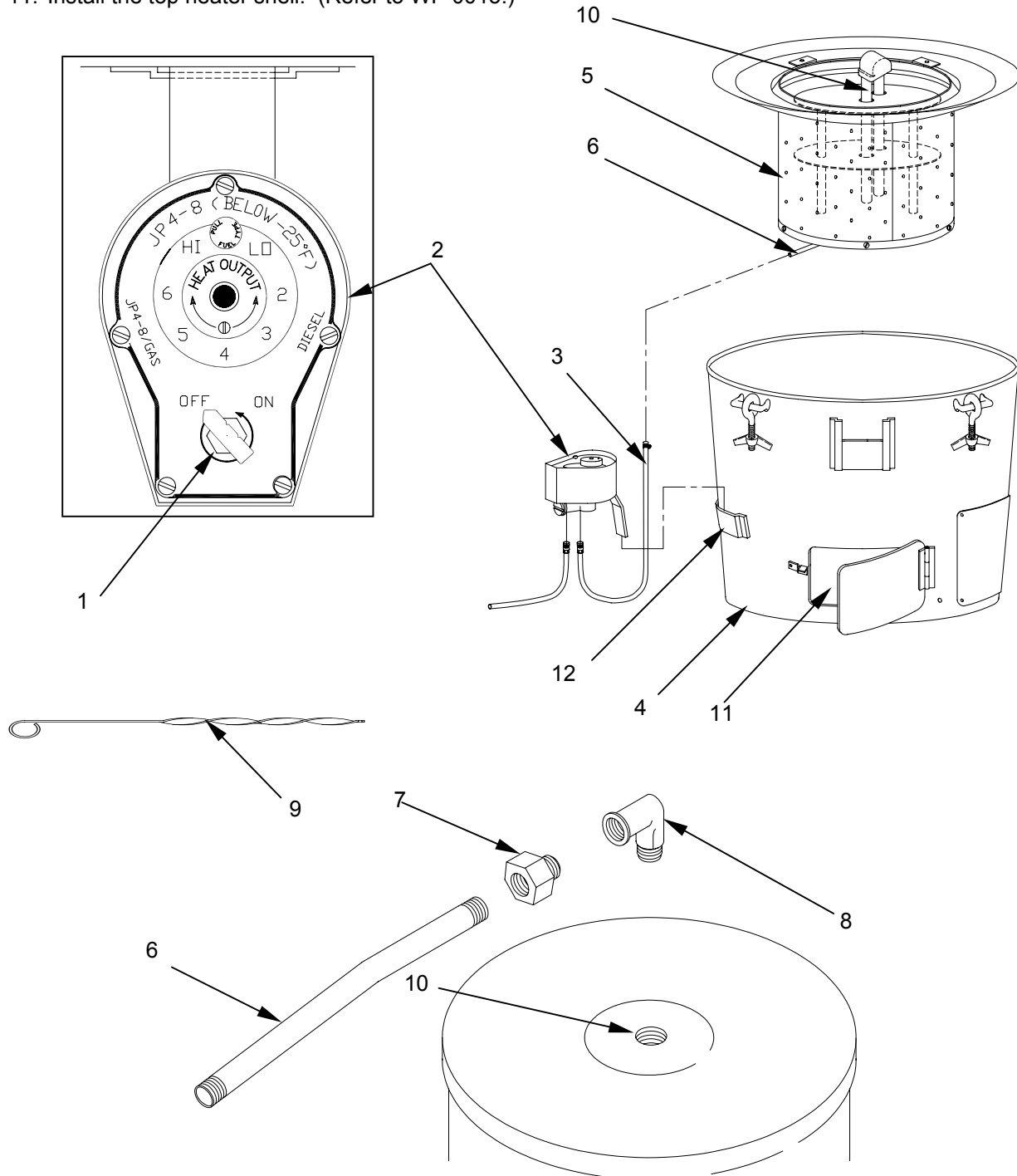

END OF WORK PACKAGE

THIS PAGE INTENTIONALLY LEFT BLANK

UNIT MAINTENANCE
H-45 LARGE RADIANT SPACE HEATER
(TYPE II, LIQUID FUEL)
NSN 4520-01-329-3451
FLOW CONTROL BURNER HOSE
REPLACE

INITIAL SETUP :**Tools**

General Mechanic's Tool Kit (WP 0041 00,
Table 2, Item 1)

Personnel Required

One

Materials/Parts

Absorbent Material (WP 0052 00, Table 1,
Item 1)

Equipment Condition

Heater shut down and cool (WP 0005 00)

H-45 TYPE II (LIQUID FUEL) HEATER**REPLACE**

Turn the fuel OFF/ON control on the fuel flow control valve **(1)** to the OFF position, and place a petroleum absorbent mat under the fuel flow control valve **(1)**.

1. Disconnect the flow control burner hose **(2)** from the fuel flow control valve outlet fitting **(3)**.
2. Open the front base heater door **(4)**.
3. Loosen the nut **(5)** securing the flow control burner hose **(2)** to the pipe nipple **(6)**, and remove the flow control burner hose **(2)** from the pipe nipple **(6)**.
4. Install the replacement flow control burner hose **(2)**, and dispose of the petroleum absorbent mat in an authorized location.

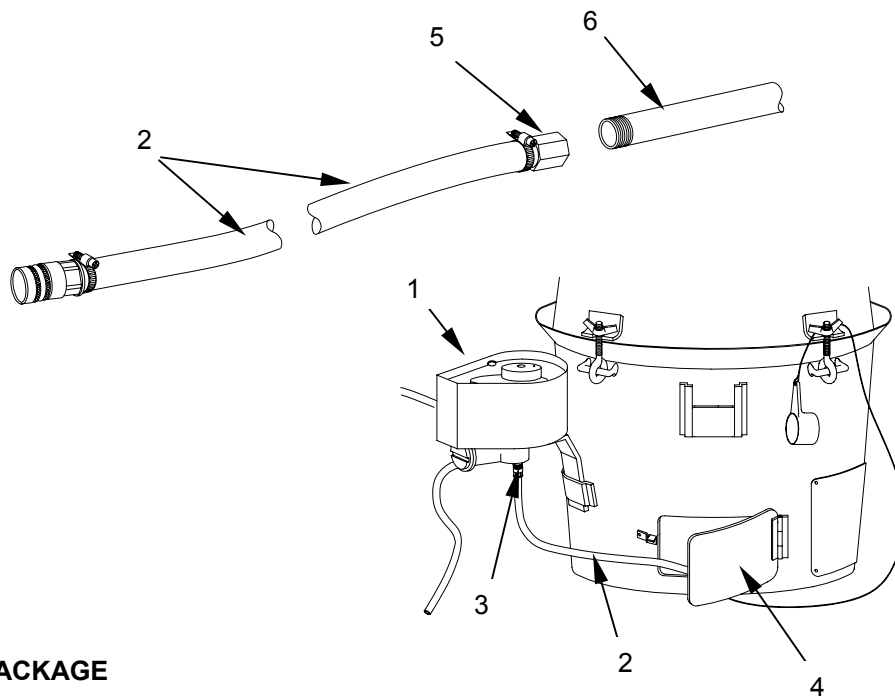

END OF WORK PACKAGE

THIS PAGE INTENTIONALLY LEFT BLANK

UNIT MAINTENANCE
H-45 LARGE RADIANT SPACE HEATER
(TYPE II, LIQUID FUEL)
NSN 4520-01-329-3451
HIGH FIRE RING
SERVICE, REPAIR, REPLACE

INITIAL SETUP:**Tools**

General Mechanic's Tool Kit (WP 0041 00, Table 2, Item 1)

Personnel Required

One

Materials/Parts

Absorbent Material (WP 0052 00, Table 1, Item 1)
Anti-seize compound (WP 0052 00, Table 1, Item 2)
Brush (WP 0052 00, Table 1, Item 3)
Item 2)
Rags (WP 0052 00, Table 1, Item 7)

References

WP 0005 00, WP 0013 00

Equipment Condition

Heater shut down and cool (WP 0005 00)
Top heater shell removed (WP 0013 00)

H-45 TYPE II (LIQUID FUEL) HEATER HIGH FIRE RING ASSEMBLY**REMOVE**

Remove the screws **(1)** and clamps **(2)** securing the high fire ring **(3)**, and lift the high fire ring out of the burner shell assembly **(4)**.

SERVICE

Using clean fuel, rags, and a brush, clean the high fire ring **(3)** as necessary to remove soot and carbon buildup.

REPAIR

Straighten bends and dents to the clamps **(2)** and high fire ring **(3)** to the extent possible.

REPLACE

Replace the high fire ring **(3)** and clamps **(2)** if they are corroded or severely bent.

INSTALL

1. Position the high fire ring **(3)** on the burner shell assembly **(4)**.
2. Install the high fire ring clamps **(2)**, apply anti-seize compound to the screw threads **(1)**, and secure the clamps **(2)** with the screws **(1)**. Be sure the high fire ring **(3)** is properly seated, level, and not obstructing the top row of the burner holes.
3. Install the top heater shell (refer to WP 0013).

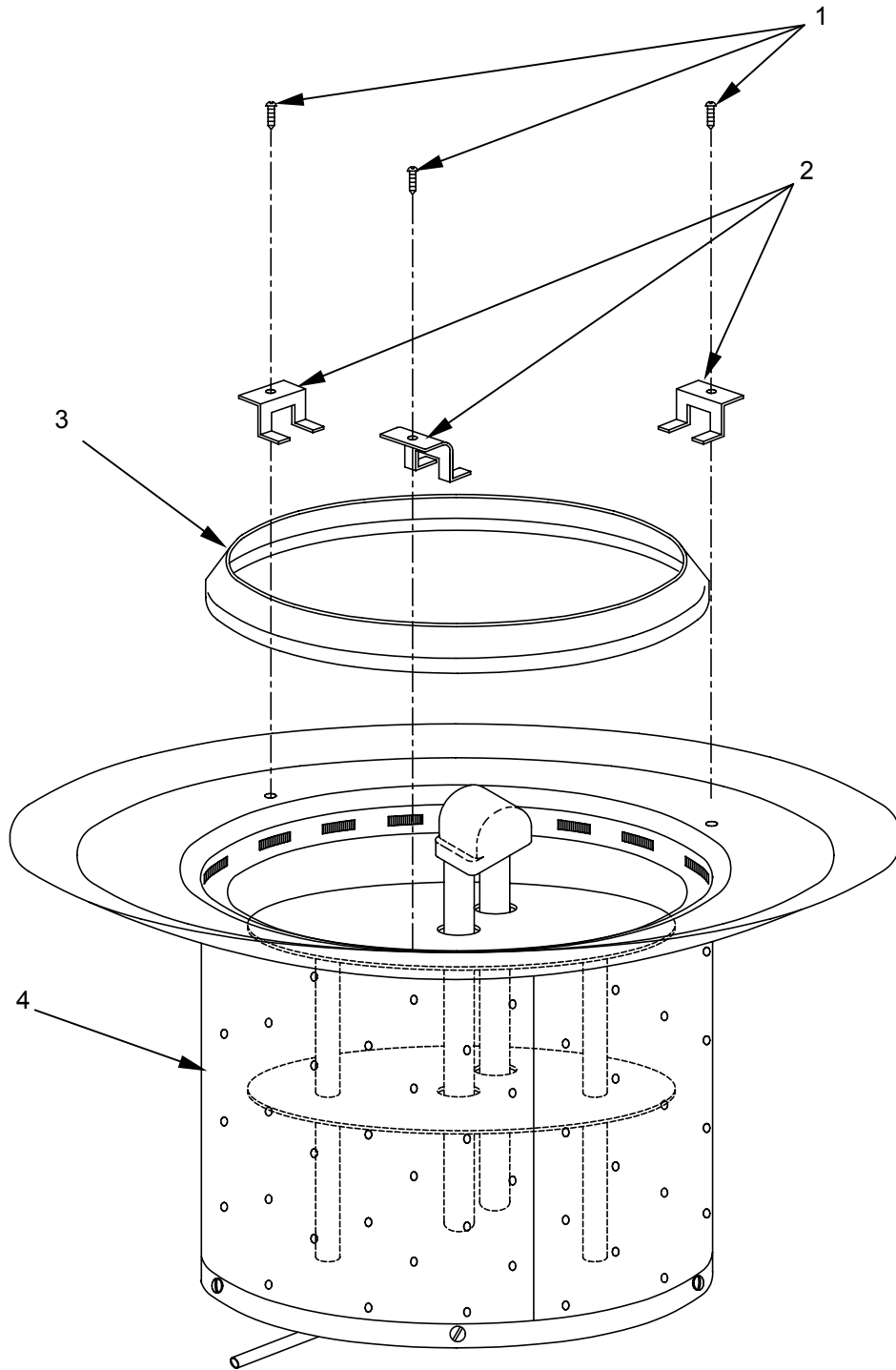

END OF WORK PACKAGE

**UNIT MAINTENANCE
H-45 LARGE RADIANT SPACE HEATER
(TYPE II, LIQUID FUEL)
NSN 4520-01-329-3451
CUP AND CABLE ASSEMBLY
SERVICE, REPAIR, REPLACE**

INITIAL SETUP :**Tools**

General Mechanic's Tool Kit (WP 0041 00,
Table 2, Item 1)

Equipment Condition

Heater shut down and cool (WP 0005 00)

Personnel Required

One

H-45 TYPE II (LIQUID FUEL) HEATER CUP/CABLE ASSEMBLY**SERVICE**

Tighten loose fasteners as necessary.

REMOVE

1. Open the front base heater door **(1)**.
2. Remove the nut **(2)**, lock washer **(3)**, flat washers **(4,5)**, and bolt **(6)** securing the cable **(7)** to the heater body base **(8)**.
3. Remove the cup **(9)** and cable **(7)**.

REPAIR

Replace missing fasteners **(2-6)**, cable **(7)**, or cup **(9)**.

REPLACE

If the entire cup and cable assembly **(2-7, 9)** is missing, replace the entire assembly.

INSTALL

1. Insert the bolt **(6)** through the hole **(10)** in the heater body base **(8)**.
2. Install one flat washer **(4)** over the bolt **(6)**. Place the loop end of the cable **(7)** over the bolt **(6)**. Install the second flat washer **(5)**, lock washer **(3)**, and nut **(2)** on the bolt **(6)** and tighten.

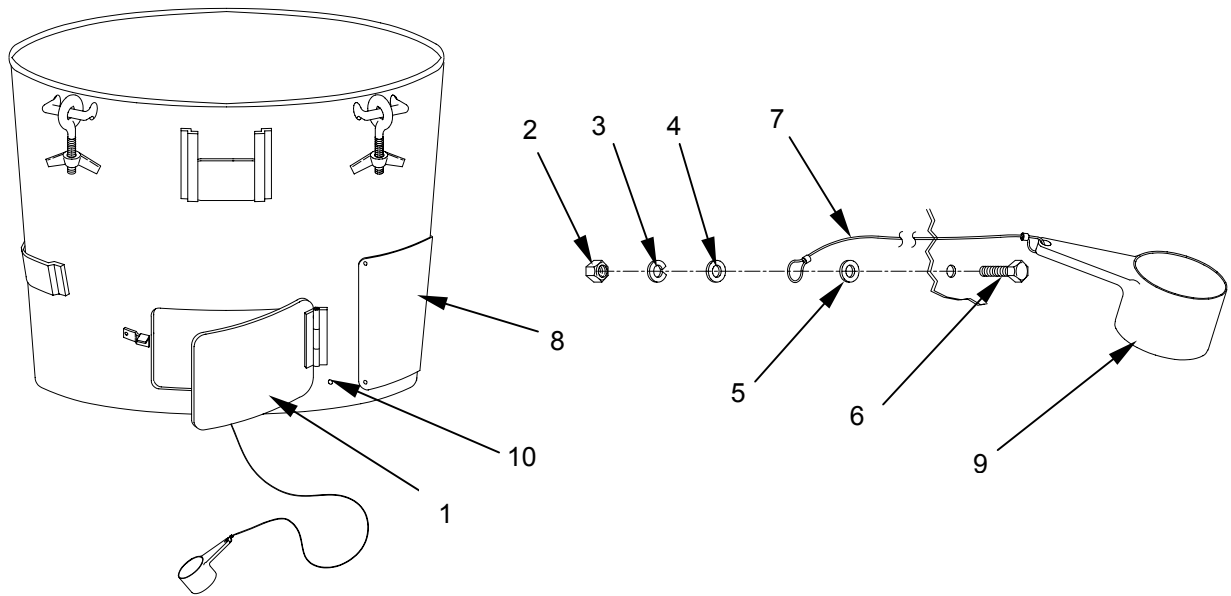

END OF WORK PACKAGE

**UNIT MAINTENANCE
H-45 LARGE RADIANT SPACE HEATER
(TYPE II, LIQUID FUEL)
NSN 4520-01-329-3451
FUEL FLOW CONTROL VALVE
INSPECT, SERVICE, REPLACE**

INITIAL SETUP :**Tools**

General Mechanic's Tool Kit (WP 0041 00,
Table 2, Item 1)

Personnel Required

One

Materials/Parts

Absorbent Material (WP 0052 00, Table 1,
Item 1)

Brush (WP 0052 00, Table 1, Item 3)

Rags (WP 0052 00, Table 1, Item 7)

Equipment Condition

Heater shut down and cool (WP 0005 00)

H-45 TYPE II (LIQUID FUEL) HEATER FUEL FLOW CONTROL VALVE**REMOVE**

1. Turn the OFF/ON control (1) on the fuel flow control valve (2) to the OFF position.
2. Place an absorbent pad under the fuel flow control valve (2), and disconnect the flow control burner hose (3), the fuel supply hose (4), and the fuel overflow hose (5) from the fuel flow control valve (2). Place the hose ends on the petroleum absorbent mat.
3. Remove the fuel flow control valve (2) from the bracket support (6) on the heater body base (7).
4. Unscrew the fuel strainer (8) and the gasket (9) on the fuel flow control valve (2).
5. Inspect the fuel flow control valve (2), fuel strainer (8), and gasket (9) for dirt, sediment, or other obstructions.

SERVICE

If necessary, clean the fuel flow control valve (2), fuel strainer (8), and gasket (9) with clean fuel, rags, and a brush to remove dirt or other obstructions.

REPLACE

If the fuel flow control valve (2) is damaged or inoperable, replace it. Transfer the fuel flow control mounting valve bracket from the replaced fuel flow control valve (2) to the replacement fuel flow control valve (2).

INSTALL

1. Install the gasket (9) and fuel strainer (8) in the fuel flow control valve (2). Tighten only enough to prevent leakage.
2. Connect the flow control burner hose (3), the fuel supply hose (4), and the fuel overflow hose (5) to the fuel flow control valve (1).
3. Turn the fuel OFF/ON control (1) on the fuel flow control valve (2) to ON, and check for leaks.

4. Install the fuel flow control valve (2) on the bracket support (6) on the heater body base (7).

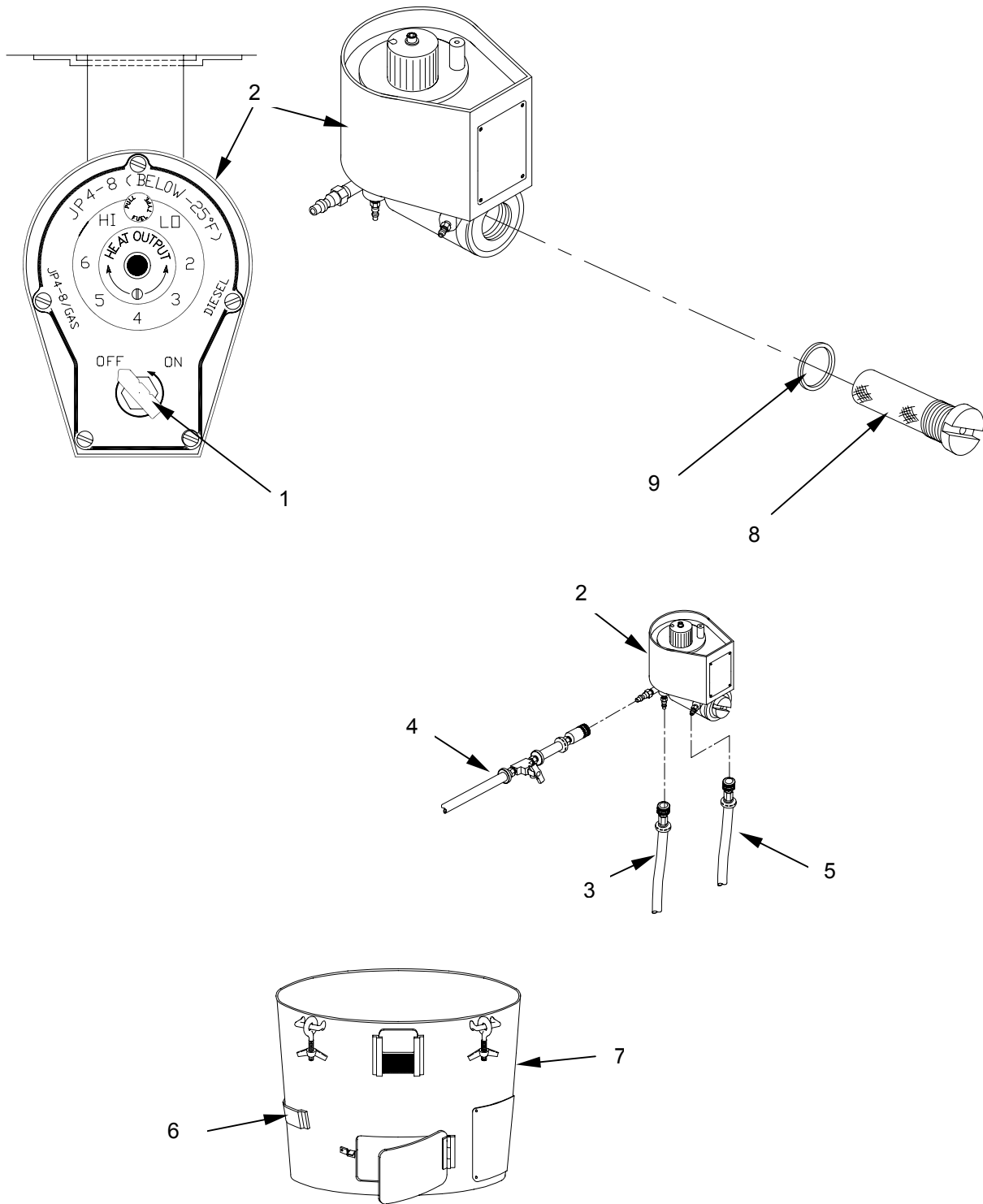

END OF WORK PACKAGE

**OPERATOR AND UNIT MAINTENANCE
H-45 LARGE RADIANT SPACE HEATER
(TYPE I, SOLID FUEL)
NSN 4520-01-354-1191
(TYPE II, LIQUID FUEL)
NSN 4520-01-329-3451
REFERENCES**

SCOPE

This section lists all forms, pamphlets, field manuals, technical manuals, Army regulations, military specifications, and military standards referenced in the manual.

FORMS

Equipment Inspection and Maintenance Worksheet	DA Form 2404
Quality Deficiency Report	SF 368
Recommended Changes to Equipment Technical Publications	DA Form 2028-2
Recommended Changes to Publications/ Logistics Maintenance Data	NAVMC 10772
Report of Discrepancy.....	SF 364
Report of Packaging and Handling Deficiencies	SF 362

TECHNICAL MANUALS

Assembly and Fabrication Procedures for Accessories Required	
Equipment Record Procedures	TM 4700-15/1F
Procedures for Destruction of Equipment to Prevent Enemy Use	TM 750-244-3

MISCELLANEOUS PUBLICATIONS

Department of the Navy Information Security Program.....	OPNAVINST 5510.1H
NBC Contamination.....	FM 3-5
The Army Maintenance Management System (TAMMS).....	DA PAM 738-750

END OF WORK PACKAGE

THIS PAGE INTENTIONALLY LEFT BLANK

**OPERATOR AND UNIT MAINTENANCE
H-45 LARGE RADIANT SPACE HEATER
(TYPE I, SOLID FUEL)
NSN 4520-01-354-1191
(TYPE II, LIQUID FUEL)
NSN 4520-01-329-3451**

MAINTENANCE ALLOCATION CHART, INTRODUCTION

THE ARMY MAINTENANCE SYSTEM MAINTENANCE ALLOCATION CHART (MAC)

INTRODUCTION

This introduction provides a general explanation of all maintenance and repair functions authorized at various maintenance levels under the standard Army Maintenance System concept.

The MAC (immediately following the introduction) designates overall authority and responsibility for the performance of maintenance functions on the identified end item or component. The application of the maintenance functions to the end item or component shall be consistent with the capacities and capabilities of the designated maintenance levels, which are shown on the MAC in column (4) as:

Unit — includes two subcolumns, C (operator/crew) and O (unit) maintenance
Direct Support — includes an F subcolumn
General Support — includes an H subcolumn
Depot — includes a D subcolumn

The tools and test equipment requirements (immediately following the MAC) list the tools and test equipment (both special tools and common tool sets) required for each maintenance function as referenced from the MAC.

The remarks (immediately following the tools and test equipment requirements) contain supplemental instructions and explanatory notes for a particular maintenance function.

MAINTENANCE FUNCTIONS

Maintenance functions will be limited to and are defined as follows:

1. **Inspect.** To determine the serviceability of an item by comparing its physical, mechanical, and/or electrical characteristics with established standards through examination (such as by sight, sound, or feel.)
2. **Test.** To verify serviceability by measuring the mechanical, pneumatic, hydraulic, or electrical characteristics of an item and comparing those characteristics with prescribed standards.
3. **Service.** To perform operations required periodically to keep an item in proper operating condition (such as cleaning; decontaminating, when required; preserving; draining; painting; or replenishing fuel, lubricants, chemical fluids, or gases).
4. **Adjust.** To maintain or regulate, within prescribed limits, by bringing into proper or exact position, or by setting the operating characteristics to specified parameters.
5. **Align.** To adjust specified variable elements of an item to bring about optimum performance.
6. **Calibrate.** To determine and cause corrections to be made, or to be adjusted on instruments, tests, measuring, and diagnostic equipment used in precision measurement. This consists of comparisons of two instruments, one of which is a certified standard of known accuracy, to detect and adjust any discrepancy in the accuracy of the instrument being compared.

7. **Remove/Install.** To remove and install the same item when required to perform service or other maintenance functions. Install may be the act of emplacing, seating, or fixing into position a spare, repair part, or module (component or assembly) in a manner to allow the proper function of equipment or system.
8. **Replace.** To remove an unserviceable item and install a serviceable counterpart in its place. A replacement is authorized by the MAC and is shown as the 3rd position code of the SMR code.
9. **Repair.** To perform maintenance services including fault location/troubleshooting, removal/installation, and disassembly/assembly procedures. Also, to perform maintenance actions to identify troubles and restore serviceability to an item by correcting specific damage, fault, malfunction, or failure in a part, subassembly, module (component or assembly), end item, or system.

NOTE

The following definitions are applicable to the "repair" maintenance function:

Services – Inspect, test, service, adjust, align, calibrate, and/or replace.

Fault location/troubleshooting —The process of investigating and detecting the cause of equipment malfunctioning; the act of isolating a fault within a system or Unit Under Test (UUT).

Disassembly/assembly – The step-by-step breakdown (taking apart) of a spare/functional group-coded item to the level of its least component that is assigned an SMR code for the level of maintenance under consideration (such as one identified as maintenance significant).

Actions – Welding, grinding, riveting, straightening, facing, machining, and or resurfacing.

10. **Overhaul.** To perform the maintenance effort (service/action) prescribed to restore an item to a completely serviceable/operational condition as required by maintenance standards in appropriate technical publications (such as the DMWR). Overhaul is normally the highest degree of maintenance performed by the Army. Overhaul does not normally return an item to like-new condition.
11. **Rebuild.** To perform those services/actions necessary for the restoration of unserviceable equipment to a like-new condition in accordance with original manufacturing standards. Rebuild is the highest degree of material maintenance applied to Army equipment. The rebuild operation includes the act of returning to zero those age measurements (such as hours/miles) considered in classifying Army equipment and/or components.

EXPLANATION OF COLUMNS IN THE MAC

Column (1) – Group Number. Column 1 contains the functional group code numbers, the purpose of which is to identify maintenance significant components, assemblies, subassemblies, and modules with the next higher assembly.

Column (2) – Component/Assembly. Column 2 contains the names of components, assemblies, subassemblies, and modules for which maintenance is authorized.

Column (3) – Maintenance Function. Column 3 contains the functions to be performed on the item listed in Column 2. (For a detailed explanation, refer to the previous section entitled “Maintenance Functions”.)

Column (4) – Maintenance Level. Column 4 contains, by the listing of a work time figure (expressed as man-hours shown as whole hours or decimals) in the appropriate subcolumn(s), the level of maintenance authorized to perform the function listed in Column 3. This figure represents the active time required to perform that maintenance function at the indicated level of maintenance. If the number or the complexity of the tasks within the listed maintenance function vary at different maintenance levels, appropriate work time figures will be shown for each level. The work time figure represents the average time required to restore an item (assembly, subassembly, component, module, end item, or system) to a serviceable condition under typical field operating conditions. This time includes item preparation (such as any necessary disassembly/assembly time), troubleshooting/fault location time, and quality assurance/quality control time in addition to the time required to perform the specific tasks identified for the maintenance functions authorized in the MAC. The system designations for the various maintenance levels are shown below:

C	Operator or crew
F	Direct Support Maintenance
D	Depot Maintenance
O	Unit Maintenance
H	General Support Maintenance

Column (5) – Tools and Equipment. Column 5 contains, by code, those common tool sets (not individual tools), common TMDE and special tools, special TMDE, and support equipment required to perform the designated function.

Column (6) – Remarks. Column 6, when applicable, contains a letter code, in alphabetic order, which is keyed to the remarks contained in Table 3.

EXPLANATION OF COLUMNS IN THE TOOLS AND TEST EQUIPMENT REQUIREMENTS

Column (1) – Tool or Test Equipment Reference Code. Column 1 contains the tool or test equipment reference code that correlates with a code used in Column 5 of the MAC.

Column (2) – Maintenance Level. Column 2 contains the lowest level of maintenance authorized to use the tool or test equipment.

Column (3) – Nomenclature. Column 3 contains the name or identification of a tool or test equipment.

Column (4) – National Stock Number (NSN). Column 4 contains the NSN of the tool or test equipment.

Column (5) – Tool Number. Column 5 contains the manufacturer’s part number, model number, or type number.

EXPLANATION OF COLUMNS IN REMARKS

Column (1) – Remarks Code. Column 1 contains the code recorded in Column 6 of the MAC.

Column (2) – Remarks. Column 2 contains the information pertinent to the maintenance function being performed as indicated in the MAC.

TABLE 1. MAC FOR HEATER, SPACE, RADIANT, LARGE (H-45)

(1) Group Number	(2) Component/Assembly	(3) Maintenance Function	(4) Maintenance Level					(5) Tools & Equip.	(6) Remarks
			Unit		Direct Support	General Support	Depot		
			C	O	F	H	D		
00	Heater, Space, Radiant, Large (H-45)								
01	Type I (Solid Fuel)								
0101	Heater Body Base	Inspect Service Replace	.1 .2 .1						
010101	Heater Body Base Door Latches	Inspect Replace	.1	.1			1		
0102	Top Heater Shell	Inspect Service Replace	.1 .2 .1						
0103	Adapter Ring	Inspect Service Replace Repair	.1 .2 .1	.2			1		
0104	Grate Assembly	Inspect Service Replace Repair	.1 .2 .1	.2			1		
0105	Stack Cap Assembly	Inspect Service Replace Repair	.1 .2 .1	.2			1		
0106	Flue Damper	Inspect Service Replace	.1 .1 .1						
0107	Spark Arrester	Inspect Service Replace	.1 .1 .1						
0108	Stack Pipe Assembly	Inspect Service Replace	.2 .3 .2						

TABLE 1. MAC FOR HEATER, SPACE, RADIANT, LARGE (H-45) – CONTINUED

(1) Group Number	(2) Component/Assembly	(3) Maintenance Function	(4) Maintenance Level					(5) Tools & Equip.	(6) Remarks
			Unit		Direct Support	General Support	Depot		
			C	O	F	H	D		
02	Type II (Liquid Fuel)								
0201	Heater Body Base	Inspect Service Replace	.1 .2	.2				1	A
020101	Heater Body Base Door Latches	Inspect Service Replace Repair	.1 .1	.1 .1				1 1	
0202	Top Heater Shell	Inspect Service Replace	.1 .2 .1						
0203	Burner Shell Assembly	Inspect Service Replace Repair	.1 .2 .2	.2 .3 .2				1	
0204	Superheater Assembly	Inspect Service Replace	.1 .1 .2						
0205	Burner Cap Assembly	Inspect Service Replace	.1 .2 .2						
0206	Supply-Flow Control Hose Assembly	Inspect Replace	.1 .2						
0207	Flow Control-Burner Hose Assembly	Inspect Replace	.1	.2				1	
0208	Overflow Hose Assembly	Inspect Replace	.1 .1						
0209	High Fire Ring	Inspect Service Replace Repair	.1	.1 .3 .3				1 1 1	
0210	Cup/Assembly	Inspect Service Repair Replace	.1	.1 .2 .1				1 1 1	

TABLE 1. MAC FOR HEATER, SPACE, RADIANT, LARGE (H-45) – CONTINUED

(1) Group Number	(2) Component/Assembly	(3) Maintenance Function	(4) Maintenance Level					(5) Tools & Equip.	(6) Remarks
			Unit		Direct Support	General Support	Depot		
			C	O	F	H	D		
0211	Stack Cap Assembly	Inspect	.1					1	
		Service	.2						
		Replace	.1						
		Repair		.2					
0212	Fuel Flow Control Valve	Inspect	.1	.2			1	B	
		Service		.2			1		
		Replace		.1					
0213	Gravity Feed Adaptor	Inspect	.1						
		Replace	.1						
0214	Stack Assembly	Inspect	.2						
		Service	.3						
		Replace	.3						
03	Fuel Can Stand	Inspect	.1						
		Replace	.1						

TABLE 2. TOOLS AND TEST EQUIPMENT FOR HEATER, SPACE, RADIANT, LARGE (H-45)

(1) Tool or Test Equipment Ref Code	(2) Maintenance Level	(3) Nomenclature	(4) National Stock Number	(5) Tool Number
1	O	Tool Kit, General Mechanic's	5180-01-481-8389	(59678) DFP389J

TABLE 3. REMARKS FOR H-45

(1) Remarks Code	(2) Remarks
A	Replacement requires removal of cup/cable assembly.
B	Tool kit authorized for unit maintenance level (O) only.

END OF WORK PACKAGE

**UNIT MAINTENANCE
H-45 LARGE RADIANT SPACE HEATER
(TYPE I, SOLID FUEL)
NSN 4520-01-354-1191
(TYPE II, LIQUID FUEL)
NSN 4520-01-329-3451**

REPAIR PARTS AND SPECIAL TOOLS LIST, INTRODUCTION

SCOPE

This Repair Parts and Special Tools List (RPSTL) authorizes spare and repair parts; special tools; special tests, measurement, and diagnostic equipment (TMDE); and other special support equipment required for performance of unit maintenance of the H-45 Large Radiant Type I (Solid Fuel) and Type II (Liquid Fuel) Space Heaters. It authorizes the requisitioning, issue, and disposition of spares, repair parts, and special tools as indicated by the source, maintenance, and recoverability (SMR) codes.

GENERAL

In addition to the this Introduction work package, the RPSTL is divided into the following work packages:

1. **Repair Parts Work Packages.** Work packages containing lists of spares and repair parts authorized by this RPSTL for use in the performance of maintenance. These work packages also include parts that must be removed for replacement of the authorized parts. Parts lists are composed of functional groups in ascending alphanumeric sequence, with the parts in each group listed in ascending figure and item number sequence. Hardware is listed with the components used. Bulk materials are listed by item name in FIG. BULK at the end of the work packages. Repair parts kits are listed separately in their own functional group and work package. Repair parts for reparable special tools are also listed in a separate work package. Items listed are shown on the associated illustrations.
2. **Special Tools List Work Packages.** Work packages containing lists of special tools, special TMDE, and special support equipment authorized by this RPSTL (as indicated by Basis of Issue (BOI) information in the DESCRIPTION AND USABLE ON CODE (UOC) column). Tools that are components of common tool sets and/or Class VII are not listed.
3. **Cross-Reference Index Work Packages.** There are two cross-reference index work packages in this RPSTL: the National Stock Number (NSN) Index work package and the Part Number (P/N) Index work package. The NSN Index work package refers you to the figure and the item number. The P/N Index work package also refers you to the figure and item number.

EXPLANATION OF COLUMNS IN THE RPSTL WORK PACKAGES

Column (1) – Item No. Indicates the number used to identify items called out in the illustration.

Column (2) – Source, Maintenance, and Recoverability Code. The SMR code is a 5-position code containing supply/requisitioning information, maintenance level authorization criteria, and disposition instruction, as shown in the following breakout.

Source Code	Maintenance Code	Recoverability Code
X X	X	X
1st two positions:	3rd position:	5th position:
How you get an item	Who can install replace or use the item	Who determines disposition action on an item

*Complete Repair: Maintenance capacity, capability, and authority to perform all corrective maintenance tasks of the "Repair" function in a use/user environment in order to restore serviceability to a failed item.

1. **Source Code.** The source code tells you how to get an item needed for maintenance, repair, or overhaul of an end item/equipment. An explanation of source codes follows:

Source Code	Explanation
PA	Stock items; use the applicable NSN to request/requisition items with these source codes. They are authorized to the level indicated by the code entered in the 3rd position of the SMR code.
PB	
PC	
PD	
PE	
PF	
PG	
KB	Items with these codes are not to be requested/requisitioned individually. They are part of a kit that is authorized to the maintenance level indicated in the 3rd position of the SMR code. The complete kit must be requisitioned and applied.
KD	
KF	
MO - Made at unit/AVUM level	Items with these codes are not to be requested/requisitioned individually. They must be made from bulk material that is identified by the P/N in the DESCRIPTION AND USABLE ON CODE (UOC) column and listed in the bulk material group work package of the RPSTL. If the item is authorized to you by the 3rd position code of the SMR code, but the source code indicates it is made at a higher level, order the item from the higher level of maintenance.
MF- Made at DS/AVIM level	
MH - Made at GS level	
ML - Made at specialized repair activity (SRA)	
MD - Made at depot	
AO - Assembled by unit/AVUM level	Items with these codes are not to be requested/requisitioned individually. The parts that make up the assembled item must be requisitioned or fabricated and assembled at the level of maintenance indicated by the source code. If the item is authorized to you by the 3rd position code of the SMR code, but the source code indicates it is made at a higher level, order the item from the higher level of maintenance.
AF - Assembled by DS/AVIM level	
AH - Assembled by GS level	
AL - Assembled by SRA	
AD - Assembled by depot	
XA	Do not requisition an "XA" coded item. Order its next higher assembly. (Also, refer to the NOTE below.)
XB	If the item is not available from salvage, order it using the CAGEC and P/N.
XC	Installation drawings, diagrams, instruction sheets, field service drawings that are identified by manufacturer's P/N.
XD	Item is not stocked. Order an "XD" coded item through normal supply channels using the CAGEC and P/N, if no NSN is available.

NOTE

Cannibalization or controlled exchange, when authorized, may be used as a source of supply for items with the above source codes, except for those source coded "XA" or those aircraft support items restricted by requirements of AR 750-1.

2. **Maintenance Code.** Maintenance codes tell you the levels of maintenance authorized to use and repair support items. The maintenance codes are entered in the 3rd and 4th positions of the SMR code as follow:

- a. The maintenance code entered in the 3rd position tells you the lowest maintenance level authorized to remove, replace, and use an item.

Maintenance Code	Application/Explanation
C —	Crew or operator maintenance done within unit/AVUM maintenance.
O —	Unit/AVUM maintenance can remove, replace, and use the item.
F —	Direct support/AVIM maintenance can remove, replace, and use the item.
H —	General support maintenance can remove, replace, and use the item.
L —	SRA can remove, replace, and use the item.
D —	Depot can remove, replace, and use the item.

- b. The maintenance code entered in the 4th position tells you whether or not the item is to be repaired and identifies the lowest maintenance level with the capability to do complete repair (perform all authorized repair functions).

NOTE

Some limited repair may be done on the item at a lower level of maintenance, if authorized by the Maintenance Allocation Chart (MAC) and SMR codes.

Maintenance Code	Application/Explanation
O —	Unit/AVUM is the lowest level that can do complete repair of the item.
F —	Direct support/AVIM is the lowest level that can do complete repair of the item.
H —	General support is the lowest level that can do complete repair of the item.
L —	SRA, if applicable, is the lowest level that can do complete repair of the item.
D —	Depot is the lowest level that can do complete repair of the item.
Z —	Nonrepairable. No repair is authorized.
B —	No repair is authorized. (No parts or special tools are authorized for the maintenance of "B" coded items.) However, the item may be reconditioned at the operator level by using maintenance procedures such as cleaning, adjusting, or lubricating.

3. **Recoverability Code.** Recoverability codes are assigned to items to indicate the disposition action on unserviceable items. The recoverability code is entered in the 5th position of the SMR code as follows:

Recoverability Code	Application/Explanation
Z —	Nonrepairable item. When unserviceable, condemn and dispose of the item at the level of maintenance shown in the 3rd position of the SMR code.
O —	Repairable item. When uneconomically repairable, condemn and dispose of the item at the unit level.
F —	Repairable item. When uneconomically repairable, condemn and dispose of the item at the direct support level.
H —	Repairable item. When uneconomically repairable, condemn and dispose of the item at the general support level.
D —	Repairable item. When beyond lower level repair capability, return to depot. Condemnation and disposal of item not authorized below depot level.
L —	Repairable item. Condemnation and disposal not authorized below SRA.
A —	Item requires special handling or condemnation procedures because of specific reasons (such as precious metal content, high dollar value, critical material, or hazardous material). Refer to appropriate manuals/ directives for specific instructions.

Column (3) – National Stock Number (NSN). The NSN for the item is listed in this column.

Column (4) – The Commercial and Government Entity Code (CAGEC). The CAGEC is a 5-digit numeric code that is used to identify the manufacturer, distributor, or Government agency/activity that supplies the item.

Column (5) – Part Number (P/N). The P/N indicates the primary number used by the manufacturer (individual company, firm, corporation, or Government activity), which controls the design and characteristics of the item by means of its engineering drawings, specifications, standards, and inspection requirements to identify an item or range of items.

NOTE

When you use an NSN to requisition an item, the item you receive may have a different P/N from the number listed.

Column (6) – Description And Usable On Code (UOC).

This column includes the following information:

1. The federal item name and, when required, a minimum description to identify the item are identified in this column.
2. The P/Ns of bulk materials are referenced in this column in the line entry to be manufactured/fabricated.
3. The hardness critical item (HCI) is a support item that provides the equipment with special protection from electromagnetic pulse (EMP) damage during a nuclear attack.
4. The statement END OF FIGURE appears just below the last item description in Column 6 for a given figure in both the repair parts list and special tools list work packages.

Column (7) – Quantity per Figure (QTY). The QTY column indicates the quantity of the item used in the breakout shown on the illustration/figure, which is prepared for a functional group, subfunctional group, or an assembly. A “V” appearing in this column instead of quantity indicates that the quantity is a variable and that the quantity may change from application to application.

EXPLANATION OF CROSS-REFERENCE INDEX FORMAT AND COLUMNS

1. National Stock Number (NSN) Index Work Package.

Stock Number Column. This column lists the NSN in national item identification number (NIIN) sequence. The NIIN consists of the last nine digits of the NSN. (When using this column to locate an item, ignore the first four digits of the NSN. However, use the complete NSN (13 digits) when requisitioning by stock number.)

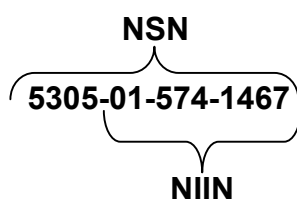

Figure (FIG.) Column. This column lists the number of the figure where an item is identified/located. The figures are in numerical order in the RPSTL work packages.

Item Column. The item number identifies the item associated with the figure listed in the adjacent FIG. column. This item is also identified by the NSN listed on the same line.

2. Part Number (P/N) Index Work Package. The P/Ns in this index are listed in ascending alphanumeric sequence (vertical arrangement of letter and number combination that place the first letter or digit of each group in order A through Z, followed by the numbers 0 through 9 and each following letter or digit in like order).

P/N Column. Indicates the P/N assigned to the item.

FIG. Column. This column lists the number of the figure where the item is identified/located in the RPSTL.

Item Column. The item number is the number assigned to the item as it appears in the figure referenced in the adjacent figure number column.

HOW TO LOCATE REPAIR PARTS

1. When NSNs or P/Ns Are Not Known.

First: Using the table of contents, determine the assembly or subassembly group to which the item belongs. This is necessary since figures are prepared for assembly groups and subassembly groups, and listings are divided into the same groups.

Second: Find the figure covering the assembly group or subassembly group to which the item belongs.

Third: Identify the item on the figure and note the number(s).

Fourth: Look in the repair parts list for the figure and item numbers. The NSNs and P/N are on the same line as the associated item numbers.

2. When NSNs Are Known.

First: If you have the NSN, look in the STOCK NUMBER column of the NSN index. The NSN is arranged in NIIN sequence. Note the figure and item number next to the NSN.

Second: Turn to the figure and locate the item number. Verify that the item is the one you are looking for.

3. When P/N Is Known.

First: If you have the P/N and not the NSN, look in the PART NUMBER column of the P/N index. Identify the figure and item number.

Second: Look up the item on the figure in the applicable repair parts list.

END OF WORK PACKAGE

THIS PAGE INTENTIONALLY LEFT BLANK

**UNIT MAINTENANCE
H-45 LARGE RADIANT SPACE HEATER
(TYPE I, SOLID FUEL)
NSN 4520-01-354-1191
REPAIR PARTS LIST, GROUP 01**

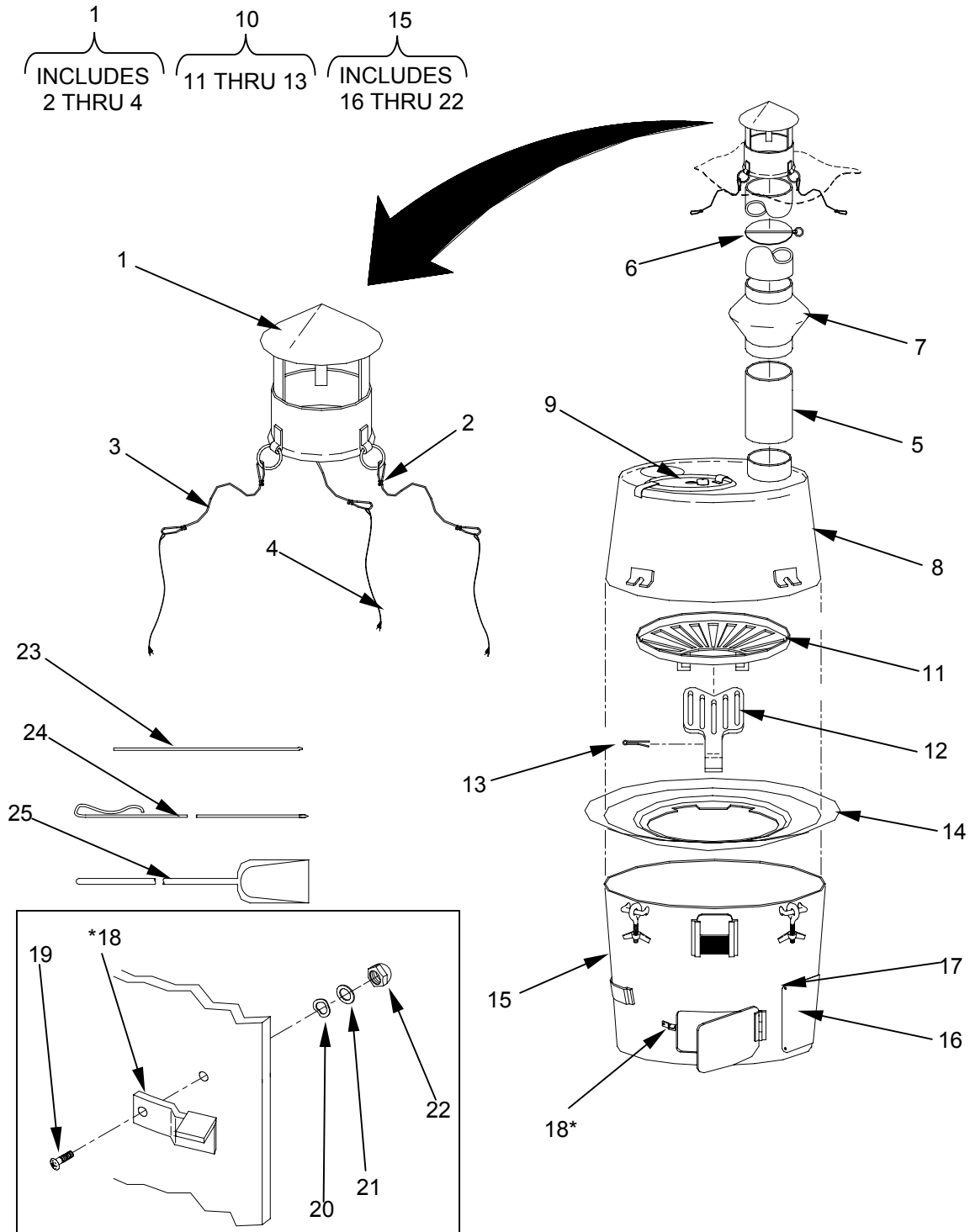

Figure 1. Group 01 Heater, Space, Radiant, Large (H-45), Type I (Solid Fuel)

(1) ITEM NO.	(2) SMR CODE	(3) NSN	(4) CAGEC	(5) PART NUMBER	(6) DESCRIPTION AND USABLE ON CODE (UOC)	(7) QTY
GROUP 01 TYPE I (SOLID FUEL)						
FIG. 1 HEATER, SPACE, RADIANT, LARGE (H-45) TYPE I (SOLID FUEL)						
1	PACOO	4520-01-469-5534	92878	171197	SHA STACK CAP ASSY	1
2	PAOZZ	4030-01-234-3281	96906	MS51844	.SWAGING SLEEVE, WIRE ROPE	6
3	MOOZZ	4010-01-216-6763	81349	MIL-W-83420	.ROPE, WIRE, FLEXIBLE	3
4	XDCZZ		92878	171218	.TENT LINE POLY PACK	1
5	PACZZ	4520-00-277-8339	81337	5-4-896	PIPE, AIR CONDITIONING-HEATING, STACK MIL-P-551	6
6	PACZZ	4520-00-288-8650	81337	5-4-356	DAMPER, FLUE 4 INCH (FCG)	1
7	PACZZ	4520-00-153-4616	81337	2-9-126	ARRESTER, SPARK, STOVE (FCG)	1
8	PBCZZ	4520-01-373-0534	81337	5-13-4407	SHELL, HEATER TOP	1
9	PACZZ	4520-01-372-4425	81337	5-13-4411	LID, SPACE HEATER	1
10	PACOO	4520-00-153-4603	81337	5-11-85-1	GRATE ASSEMBLY (FCG)	1
11	XDOZZ		81337	5-11-85-2	.GRATE, ROUND (FCG)	1
12	XDOZZ		81337	5-11-85-3	.GRATE, DRAW (FCG)	1
13	PAOZZ	5315-00-234-1672	80205	MS24665-685	.PIN, COTTER (FCG)	1
14	PACOO	5365-00-555-8537	81337	5-11-84-3	RING, ADAPTER (FCG)	1
15	PBCZZ	4520-01-373-3145	81337	5-13-4401	BASEPLATE, SPACE HEATER	1
16	XDOZZ		92878	5-13-4452	.INSTRUCTION PLATE	1
17	XDOZZ		92878	49160	.SCREW TEKS #6 X 3/8	4
18	PAOZZ	4520-01-373-0533	81337	5-13-4406	.LATCH, HEATER DOOR	2
19	PAOZZ	5305-00-050-9229	96906	MS51957-63	.SCREW, MACHINE 10-24 X 1/2	2
20	XDOZZ		92878	190369	.SPRING WASHER	2
21	PAOZZ	5310-00-014-5850	96906	MS27183-42	.WASHER FLAT 7/32 ID	2
22	XDOZZ		92878	171192	.NUT LOCK HEX CRES 10-24 THD	2
23	PACZZ	4520-00-555-8536	81337	5-11-85-4	SHAKER (FCG)	1
24	PACZZ	5340-00-368-7439	81349	MIL-P-584	POKER (FCG)	1
25	PACZZ	5120-00-293-0450	81349	MILS1485	FIRE SHOVEL,HAND (FCG)	1
END OF FIGURE						

END OF WORK PACKAGE

THIS PAGE INTENTIONALLY LEFT BLANK

THIS PAGE INTENTIONALLY LEFT BLANK

UNIT MAINTENANCE
 H-45 LARGE RADIANT SPACE HEATER
 (TYPE II, LIQUID FUEL)
 NSN 4520-01-329-3451
 REPAIR PARTS LIST, GROUP 2

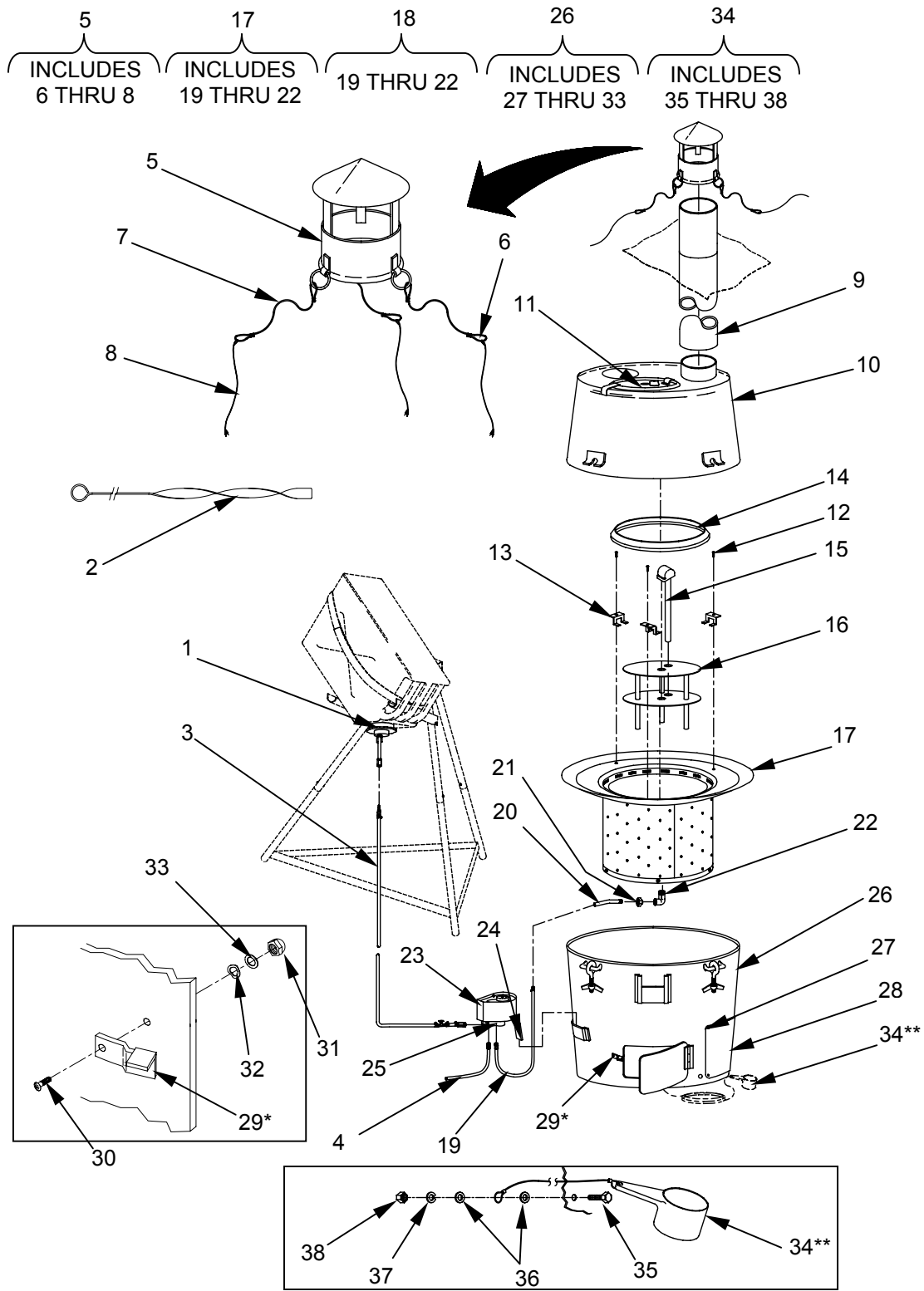

Figure 2. Group 02 Heater, Space, Radiant, Large (H-45), Type II (Liquid Fuel)

(1) ITEM NO.	(2) SMR CODE	(3) NSN	(4) CAGEC	(5) PART NUMBER	(6) DESCRIPTION AND USABLE ON CODE (UOC)	(7) QTY
GROUP 02 TYPE II (LIQUID FUEL)						
FIG. 2 HEATER, SPACE, RADIANT, LARGE (H-45) TYPE II (LIQUID FUEL)						
1	PACZZ	4520-01-469-5775	92878	171230	SHA GRAVITY ADAPTER (FGZ)	1
2	PACZZ	5110-01-374-0905	81337	5-13-4439	REAMING,HAND (FGZ)	1
3	PACZZ	4720-01-511-4501	81337	5-13-4436	HOSE ASSY SUPPLY TO FLOW CONTROL (FGZ)	1
4	PACZZ	4520-01-493-4154	81337	5-13-4449	H45 OVERFLOW HOSE (FGZ)	1
5	PACOO	4520-01-469-5534	92878	171197	SHA STACK CAP ASSY	1
6	PAOZZ	4030-01-234-3281	96906	MS51844	.SWAGING SLEEVE, WIRE ROPE	6
7	MOOZZ	4010-01-216-6763	81349	MIL-W-83420	.ROPE, WIRE, FLEXIBLE	3
8	XDCZZ		92878	171218	.TENT LINE POLY PACK	1
9	PACZZ	4520-00-277-8339	81337	5-4-896	PIPE, AIR CONDITIONING-HEATING, STACK MIL-P-551	6
10	PBCZZ	4520-01-373-0534	81337	5-13-4407	SHELL,HEATER TOP	1
11	PACZZ	4520-01-372-4425	81337	5-13-4411	LID SPACE HEATER	1
12	PAOZZ	5305-00-782-4386	96906	MS51861-33C	SCREW, TAPPING 8-18 X 5/16 (FGZ)	3
13	PAOZZ	5340-01-374-4460	81337	5-13-4451	CLAMP, SYNCHRO (FGZ)	3
14	PAOOO	5330-01-380-7919	81337	5-13-4438	SEAL RING,METAL (FGZ)	1
15	PACZZ	4520-01-375-2122	81337	5-13-4426	CAP ASSEMBLY, BURNER (FGZ)	1
16	PACZZ	4520-01-374-8268	81337	5-13-4422	SUPERHEATER ASSEMBLY (FGZ)	1
17	PAOZZ	4520-01-375-2120	81337	5-13-4415	SHELL ASSEMBLY,BURNER (FGZ)	1
18	XDOZZ		92878	171220	.BURNER, FUEL CONNECTOR S/A (FGZ)	1
19	PAOZZ	4720-01-329-3451	92878	5-13-4437	..HOSE ASSEMBLY, FLOW CONTROL- BURNER (FGZ)	1
20	XDOZZ		92878	171189	..NIPPLE (FGZ)	1
21	XDOZZ		92878	116524	..BUSHING (FGZ)	1
22	XDOZZ		92878	171188	..ELBOW (FGZ)	1
23	PAOZZ	4530-01-353-5770	81337	5-13-4454	CONTROL, FUEL FLOW, OIL BURNER ASSEMBLY (FGZ)	1
24	PAOZZ	5340-01-374-3342	81337	5-13-4433	BRACKET, MOUNTING FLOW CONTROL (FGZ)	1
25	PAOZZ	5305-01-306-9863	92878	3050	SCREW, SELF-LOCKING 1/4-20X 3/8 (FGZ)	2
26	PBOZZ	4520-01-373-3145	81337	5-13-4401	BASEPLATE, SPACE HEATER	1
27	XDOZZ		92878	49160	.SCREW TEKS #6 X 3/8	4
28	XDOZZ		92878	5-13-4452	.INSTRUCTION PLATE	1
29	PAOZZ	4520-01-373-0533	81337	5-13-4406	.LATCH,HEATER DOOR	2
30	PAOZZ	5305-00-050-9229	96906	MS51957-63	.SCREW, MACHINE 10-24 X 1/2	2
31	XDOZZ		92878	171192	.NUT LOCK HEX CRES 10-24 THD	2
32	XDOZZ		92878	190369	.SPRING WASHER	2

(1) ITEM NO.	(2) SMR CODE	(3) NSN	(4) CAGEC	(5) PART NUMBER	(6) DESCRIPTION AND USABLE ON CODE (UOC)	(7) QTY
33	PAOZZ	5310-00-014-5850	96906	MS27183-42	.WASHER FLAT 7/32 ID	2
34	XDOZZ		81337	5-13-4441	CUP AND CABLE ASSY (FGZ)	1
35	PAOZZ	5305-00-702-4523	80205	MS35307-306	.SCREW,CAP,HEXAGON HEAD 1/4-20 X 3/4 (FGZ)	1
36	PAOZZ	5310-00-880-5977	80205	MS15795-811	.WASHER, FLAT CRES .312 X .735 X .065 (FGZ)	2
37	PAOZZ	5310-01-033-8615	96906	MS51848-50	.WASHER, LOCK SPLIT 1/4 CRES (FGZ)	1
38	PAOZZ	5310-00-903-5966	96906	MS51971-1	.NUT, PLAIN,HEXAGON, CRES 1/4-20 (FGZ)	1
END OF FIGURE						

END OF WORK PACKAGE

THIS PAGE INTENTIONALLY LEFT BLANK

UNIT MAINTENANCE
H-45 LARGE RADIANT SPACE HEATER
(TYPE II, LIQUID FUEL)
NSN 4520-01-329-3451
COLLAPSIBLE FUEL CAN STAND
REPAIR PARTS LIST, GROUP 3

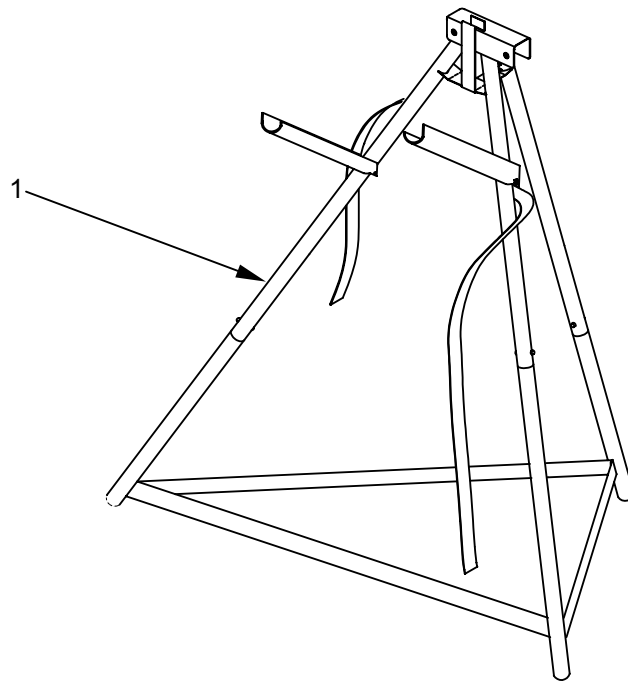

Figure 3. Group 03 Stand, Collapsible Fuel Can

(1) ITEM NO.	(2) SMR CODE	(3) NSN	(4) CAGEC	(5) PART NUMBER	(6) DESCRIPTION AND USABLE ON CODE (UOC)	(7) QTY
					GROUP 03 TYPE II (LIQUID FUEL)	
					FIG. 3 STAND, COLLAPSIBLE FUEL CAN	
1		4520-01-465-4430	92878	171250	HEATER CAN STAND	1
					END OF FIGURE	

END OF WORK PACKAGE

THIS PAGE INTENTIONALLY LEFT BLANK

UNIT MAINTENANCE
H-45 LARGE RADIANT SPACE HEATER
(TYPE I, SOLID FUEL)
NSN 4520-01-354-1191
(TYPE II, LIQUID FUEL)
NSN 4520-01-329-3451
BULK MATERIALS LIST
REPAIR PARTS LIST, GROUP 4

(1) ITEM NO.	(2) SMR CODE	(3) NSN	(4) CAGEC	(5) PART NUMBER	(6) DESCRIPTION AND USABLE ON CODE (UOC)	(7) QTY
GROUP 04 BULK MATERIALS						
FIG. BULK						
1	MOOZZ	4720-00-273-9514	81349	MIL-H-13444	HOSE, NONMETALLIC (FGZ)	V
2	MOOZZ	8340-00-252-6913	81349	MIL-L-1709	CORD, COTTON, BRAIDED, .021 DIA MIL-L-1709, CLASS D, TYPE LIV	V
3	MOOZZ	9505-00-684-4843	80205	MS20995F41	WIRE, NONELECTRICAL (FGZ)	V
END OF FIGURE						

END OF WORK PACKAGE

THIS PAGE INTENTIONALLY LEFT BLANK

**UNIT MAINTENANCE
H-45 LARGE RADIANT SPACE HEATER
(TYPE I, SOLID FUEL)
NSN 4520-01-354-1191
(TYPE II, LIQUID FUEL)
NSN 4520-01-329-3451
NATIONAL STOCK NUMBER INDEX**

STOCK NUMBER	FIG.	ITEM	STOCK NUMBER	FIG.	ITEM
5310- 00-014-5850	1	21	4520- 01-375-2122	2	15
5310- 00-014-5850	2	33	5330- 01-380-7919	2	14
5305- 00-050-9229	1	19	4520- 01-465-4430	3	1
5305- 00-050-9229	2	30	4520- 01-469-5534	1	1
4520- 00-153-4603	1	10	4520- 01-469-5534	2	5
4520- 00-153-4616	1	7	4520- 01-469-5775	2	1
5315- 00-234-1672	1	13	4520- 01-493-4154	2	4
4520- 00-277-8339	1	5	4720- 01-511-4501	2	3
4520- 00-277-8339	2	9			
4520- 00-288-8650	1	6			
5120- 00-293-0450	1	25			
5340- 00-368-7439	1	24			
4520- 00-555-8536	1	23			
5365- 00-555-8537	1	14			
5305- 00-702-4523	2	35			
5305- 00-782-4386	2	12			
5310- 00-880-5977	2	36			
5310- 00-903-5966	2	38			
5310- 01-033-8615	2	37			
4010- 01-216-6763	1	3			
4010- 01-216-6763	2	7			
4030- 01-234-3281	1	2			
4030- 01-234-3281	2	6			
5305- 01-306-9863	2	25			
4720- 01-329-3451	2	19			
4530- 01-353-5770	2	23			
4520- 01-372-4425	1	9			
4520- 01-372-4425	2	11			
4520- 01-373-0533	1	18			
4520- 01-373-0533	2	29			
4520- 01-373-0534	1	8			
4520- 01-373-0534	2	10			
4520- 01-373-3145	1	15			
4520- 01-373-3145	2	26			
5110- 01-374-0905	2	2			
5340- 01-374-3342	2	24			
5340- 01-374-4460	2	13			
4520- 01-374-8268	2	16			
4520- 01-375-2120	2	17			

END OF WORK PACKAGE

THIS PAGE INTENTIONALLY LEFT BLANK

UNIT MAINTENANCE
H-45 LARGE RADIANT SPACE HEATER
(TYPE I, SOLID FUEL)
NSN 4520-01-354-1191
(TYPE II, LIQUID FUEL)
NSN 4520-01-329-3451
PART NUMBER INDEX

PART NUMBER	FIG.	ITEM	PART NUMBER	FIG.	ITEM
171197	1	1	5-13-4449	2	4
171218	1	4	5-13-4451	2	13
116524	2	21	5-13-4452	1	16
171189	2	20	5-13-4452	2	28
171192	1	22	5-13-4454	2	23
171192	2	31	5-4-356	1	6
171197	2	5	5-4-896	1	5
171218	2	8	5-4-896	2	9
171220	2	18	MIL-P-584	1	24
171230	2	1	MILS1485	1	25
171250	3	1	MIL-W-83420	1	3
171188	2	22	MIL-W-83420	2	7
190369	1	20	MS15795-811	2	36
190369	2	32	MS24665-685	1	13
2-9-126	1	7	MS27183-42	1	21
3050	2	25	MS27183-42	2	33
49160	1	17	MS35307-306	2	35
49160	2	27	MS51844	1	2
5-11-84-3	1	14	MS51844	2	6
5-11-85-1	1	10	MS51848-50	2	37
5-11-85-2	1	11	MS51861-33C	2	12
5-11-85-3	1	12	MS51957-63	1	19
5-11-85-4	1	23	MS51957-63	2	30
5-13-4401	1	15	MS51971-1	2	38
5-13-4401	2	26			
5-13-4406	1	18			
5-13-4406	2	29			
5-13-4407	1	8			
5-13-4407	2	10			
5-13-4411	1	9			
5-13-4411	2	11			
5-13-4415	2	17			
5-13-4422	2	16			
5-13-4426	2	15			
5-13-4433	2	24			
5-13-4436	2	3			
5-13-4437	2	19			
5-13-4438	2	14			
5-13-4439	2	2			
5-13-4441	2	34			

END OF WORK PACKAGE

THIS PAGE INTENTIONALLY LEFT BLANK

**UNIT MAINTENANCE
H-45 LARGE RADIANT SPACE HEATER
(TYPE 1, SOLID FUEL)
NSN 4520-01-354-1191
(TYPE II, LIQUID FUEL)
NSN 4520-01-329-3451
SPECIAL TOOLS LIST**

STOCK NUMBER	FIG.	ITEM
---------------------	-------------	-------------

There are no special tools required for the H-45 or its associated equipment.

END OF WORK PACKAGE

THIS PAGE INTENTIONALLY LEFT BLANK

**UNIT MAINTENANCE
H-45 LARGE RADIANT SPACE HEATER
(TYPE I, SOLID FUEL)
NSN 4520-01-354-1191
(TYPE II, LIQUID FUEL)
NSN 4520-01-329-3451**

COMPONENTS OF END ITEMS (COEI) AND BASIC ISSUE ITEMS (BII) LIST

SECTION I. INTRODUCTION

Scope

This section lists the COEI and BII for both types of the H-45 Large Radiant Space Heater to help you inventory items for safe and efficient operation of the equipment.

GENERAL

The COEI and BII information is divided into the following sections:

Components of End Item (COEI). This list is for information purposes only and is not authority to requisition replacements. These items are part of the H-45 Heater, but they are to be removed and separately packaged for transportation or shipment. As part of the end item, these must be with the end item whenever it is issued or transferred between property accounts. Illustrations are furnished to help you find and identify the items.

Basic Issue Items (BII). These essential items are required to place the H-45 Heaters in operation, to operate them, and to do emergency repairs. Although shipped separately packaged, BII must be with the end item during operation and when it is transferred between property accounts. Listing these items is your authority to request / requisition them for replacement based on authorization of the end item by the TOE/MTOE. Illustrations are furnished to help you find and identify the items.

EXPLANATION OF COLUMNS IN THE COEI LIST AND BII LIST

Column 1. Illustration Number: The number of the item illustrated.

Column 2. National Stock Number (NSN): The stock number of the item to be used for requisitioning purposes.

Column 3. Description, Commercial and Government Entity Code (CAGEC), and Part Number: The Federal item name (in all capital letters) followed by a minimum description when needed. The last line below the description is the CAGEC (in parenthesis) and the part number.

Column 4. Usable on Code: The code needed for parts that differ between models. The following codes apply to the H-45 heaters:

<u>Code</u>	<u>Used on</u>
FCG	Type I (Solid Fuel)
FGZ	Type II (Liquid Fuel)

Column 5. Unit of Measure (U/M): The code used for issuing the item based on the NSN.

Column 6. Qty Rqd: The quantity required.

SECTION II. COMPONENTS OF END ITEM LIST

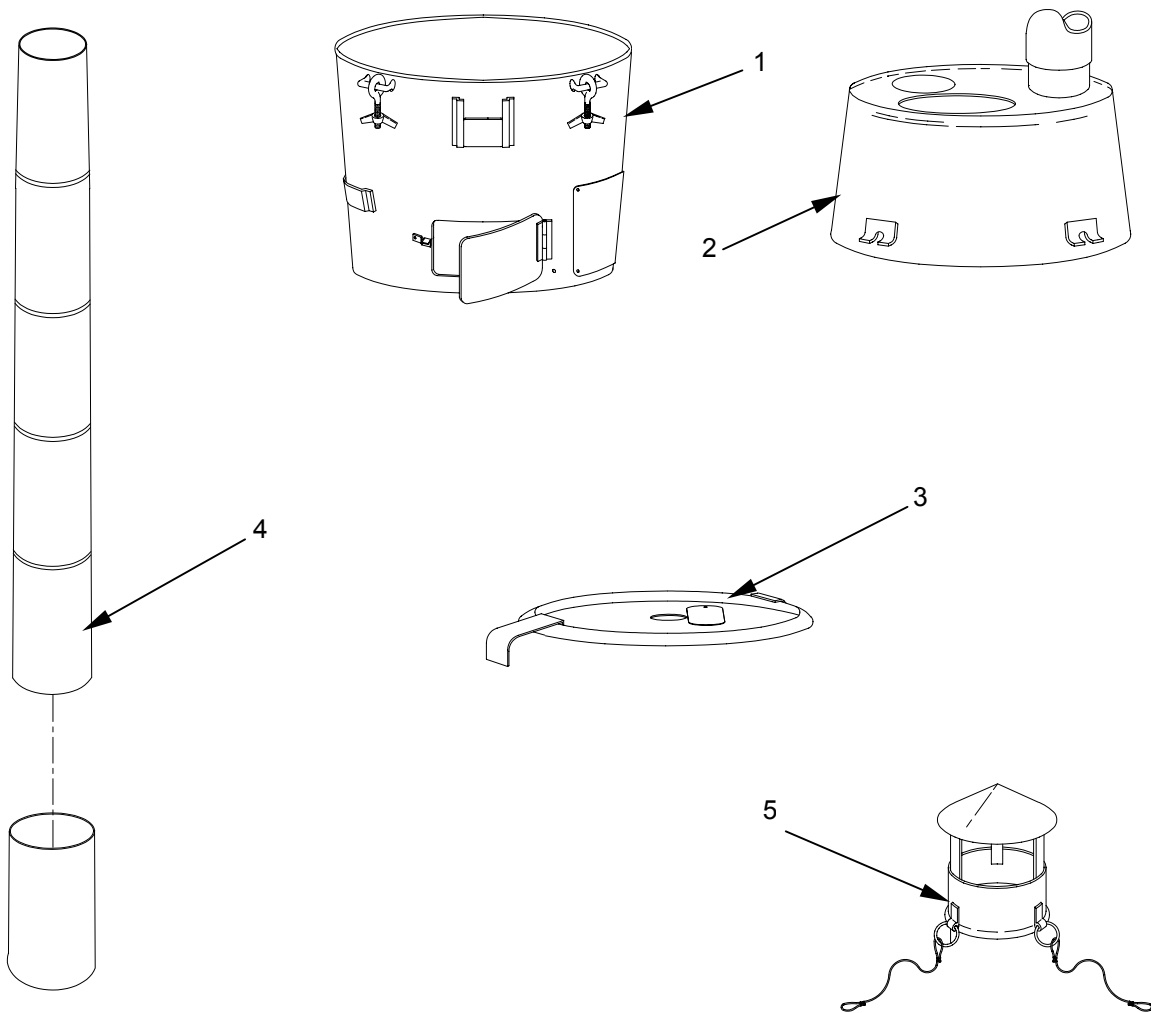

Table 1. Components of End Item List

(1) ILLUS NUMBER	(2) NATIONAL STOCK NUMBER	(3) DESCRIPTION, LOCATION, CAGEC, AND PART NUMBER	(4) USABLE ON CODE	(5) U/M	(6) QTY RQR
1	4520-01-373-3145	BASEPLATE, SPACE HEATER (81337) 5-13-4401	FCG*, FGZ**	EA	1
2	4520-01-373-0534	SHELL, HEATER TOP (81337) 5-13-4407	FCG*, FGZ**	EA	1
3	4520-01-372-4425	LID, SPACE HEATER (81337) 5-13-4411	FCG*, FGZ**	EA	1
4	4520-00-277-8339	PIPE, AIR CONDITIONING-HEATING, STACK MIL- P-551 (81337) 5-4-896	FCG*, FGZ**	EA	6
5	4520-01-469-5534	SHA STACK CAP ASSY (92878) 171197	FCG*, FGZ**	EA	1

* TYPE I SOLID FUEL, ** TYPE II LIQUID FUEL

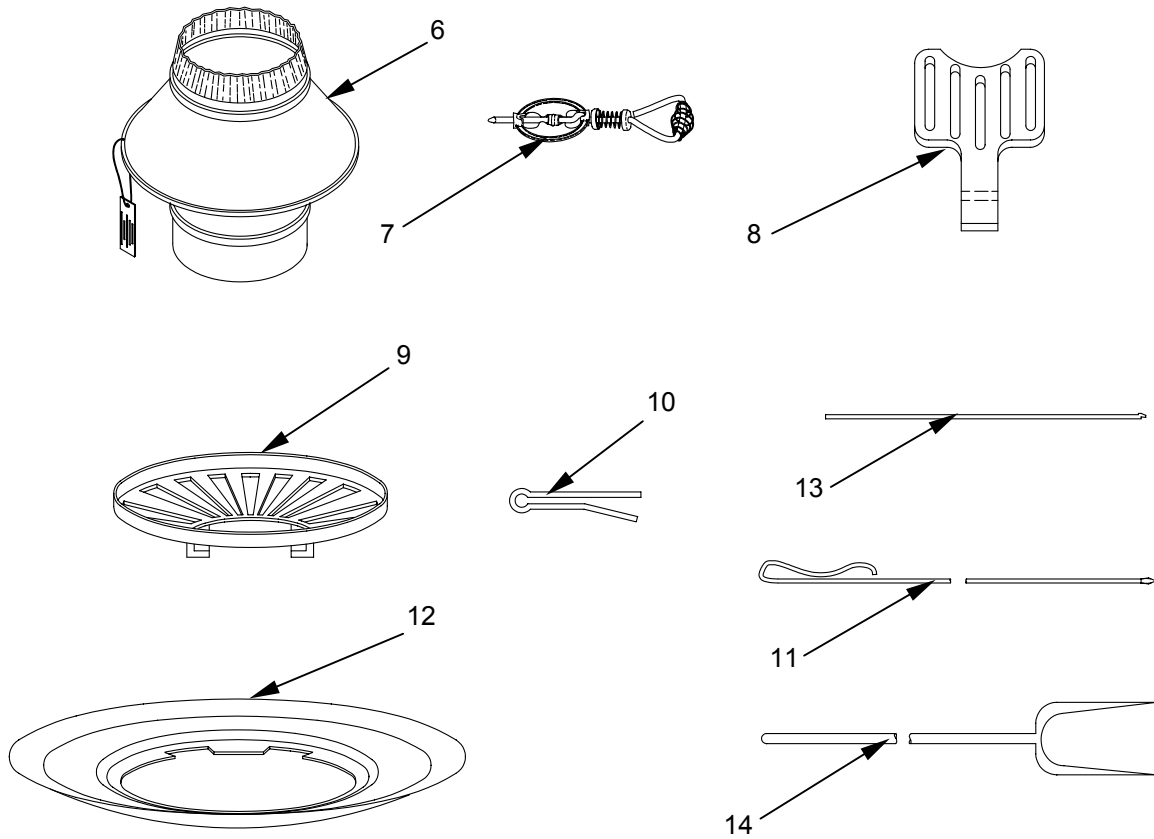

Table 1. Components of End Item List - Continued

(1) ILLUS NUMBER	(2) NATIONAL STOCK NUMBER	(3) DESCRIPTION, LOCATION, CAGEC, AND PART NUMBER	(4) USABLE ON CODE	(5) U/M	(6) QTY RQR
6	4520-00-153-4616	ARRESTER, SPARK, STOVE (81337) 2-9-126	FCG	EA	1
7	4520-00-288-8650	DAMPER, FLUE 4 INCH (81337) 5-4-356	FCG	EA	1
8	N/A	GRATE, DRAW (81337) 5-11-85-3	FCG	EA	1
9	N/A	GRATE, ROUND (81337) 5-11-85-2	FCG	EA	1
10	5315-00-234-1672	PIN, COTTER (80205) MS24665-685	FCG	EA	1
11	5340-00-368-7439	POKER (81349) MIL-P-584	FCG	EA	1
12	5365-00-555-8537	RING, ADAPTER (81337) 5-11-84-3	FCG	EA	1
13	4520-00-555-8536	SHAKER (81337) 5-11-85-4	FCG	EA	1
14	5120-00-293-0450	FIRE SHOVEL, HAND (81349) MILS1485	FCG	EA	1

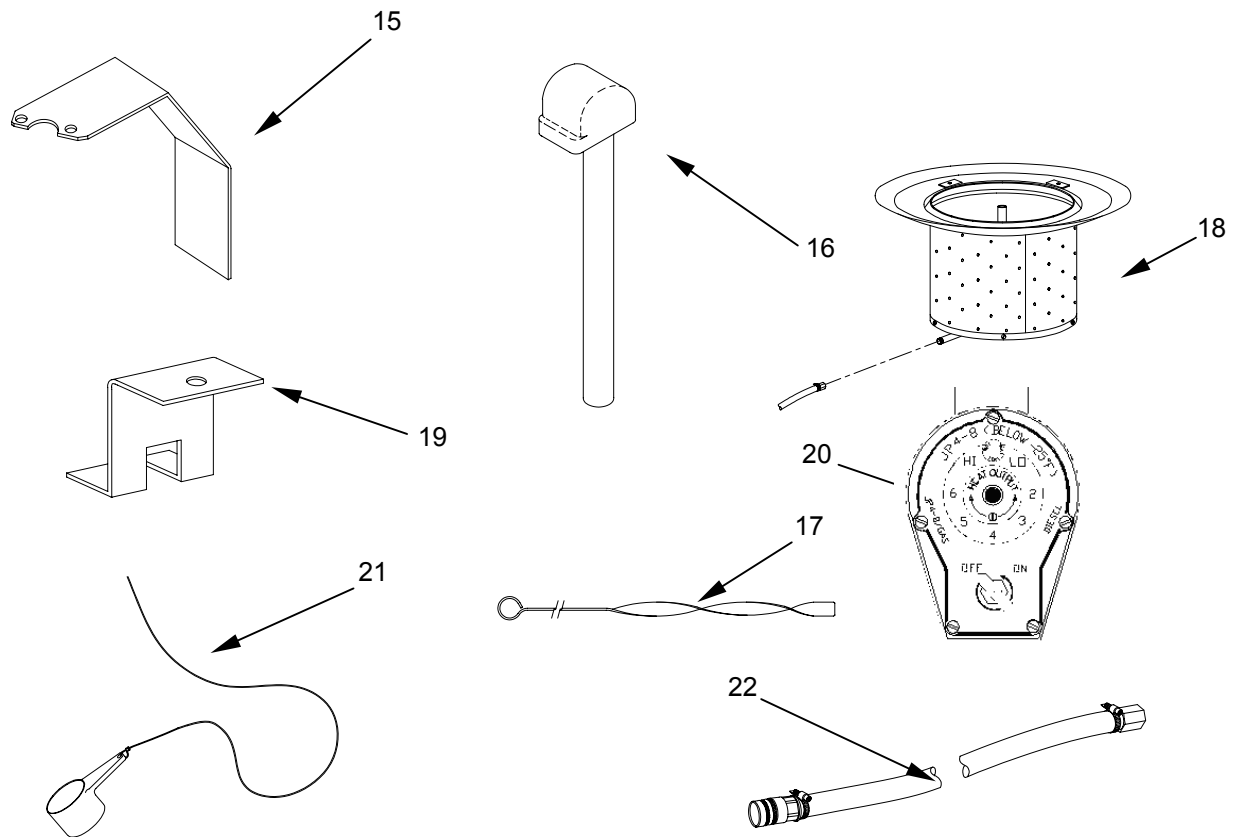

Table 1. Components of End Item List - Continued

(1) ILLUS NUMBER	(2) NATIONAL STOCK NUMBER	(3) DESCRIPTION, LOCATION, CAGEC, AND PART NUMBER	(4) USABLE ON CODE	(5) U/M	(6) QTY RQR
15	5340-01-374-3342	BRACKET, MOUNTING FUEL FLOW CONTROL (81337) 5-13-4433	FGZ	EA	1
16	4520-01-375-2122	CAP ASSEMBLY, BURNER (81337) 5-13-4426	FGZ	EA	1
17	5110-01-374-0905	REAMING, HAND (81337) 5-13-4439	FGZ	EA	1
18	4520-01-375-2120	SHELL ASSEMBLY, BURNER (81337) 5-13-4415	FGZ	EA	1
19	5340-01-374-4460	CLAMP, SYNCHRO (81337) 5-13-4451	FGZ	EA	3
20	4530-01-353-5770	CONTROL, MULTIFUEL FLOW, OIL BURNER ASSEMBLY (81337) 5-13-4454	FGZ	EA	1
21	N/A	CUP AND CABLE ASSEMBLY (81337) 5-13-4441	FGZ	EA	1
22	4720-01-329-3451	HOSE ASSEMBLY, BURNER ASSY TO FLOW CONTROL (81337) 5-13-4437	FGZ	EA	1

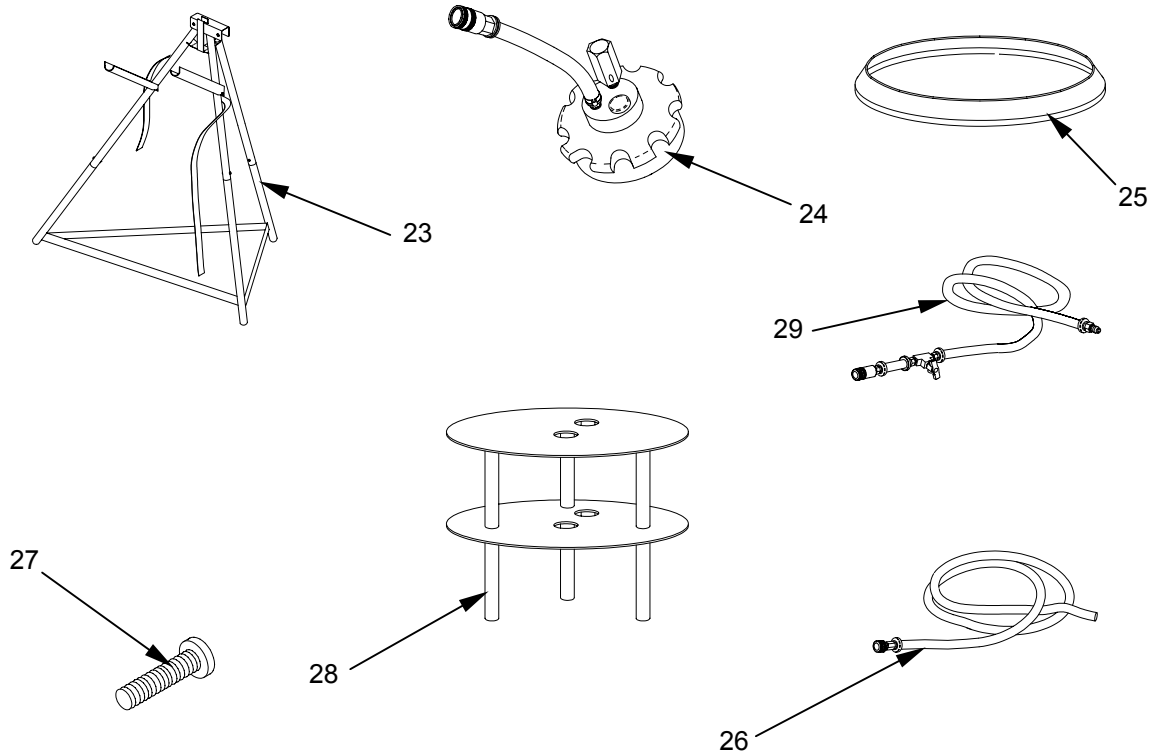

Table 1. Components of End Item List - Continued

(1) ILLUS NUMBER	(2) NATIONAL STOCK NUMBER	(3) DESCRIPTION, LOCATION, CAGEC, AND PART NUMBER	(4) USABLE ON CODE	(5) U/M	(6) QTY RQR
23	4520-01-465-4430	HEATER CAN STAND (92878) 171250	FGZ	EA	1
24	4520-01-469-5775	SHA GRAVITY ADAPTER (92878) 17123	FGZ	EA	1
25	5330-01-380-7919	SEAL RING, METAL (81337) 5-13-4438	FGZ	EA	1
26	4520-01-493-4154	H45 OVERFLOW HOSE (92878) 5-13-4449	FGZ	EA	1
27	5305-00-782-4386	SCREW, TAPPING (96906) MS51861-33C	FGZ	EA	3
28	4520-01-374-8268	SUPERHEATER ASSEMBLY (81337) 5-13-4422	FGZ	EA	1
29	4720-01-511-4501	SUPPLY-FLOW CONTROL HOSE ASSEMBLY (81337) 5-13-4436	FGZ	EA	1

SECTION III. BASIC ISSUE ITEMS (BII) LIST

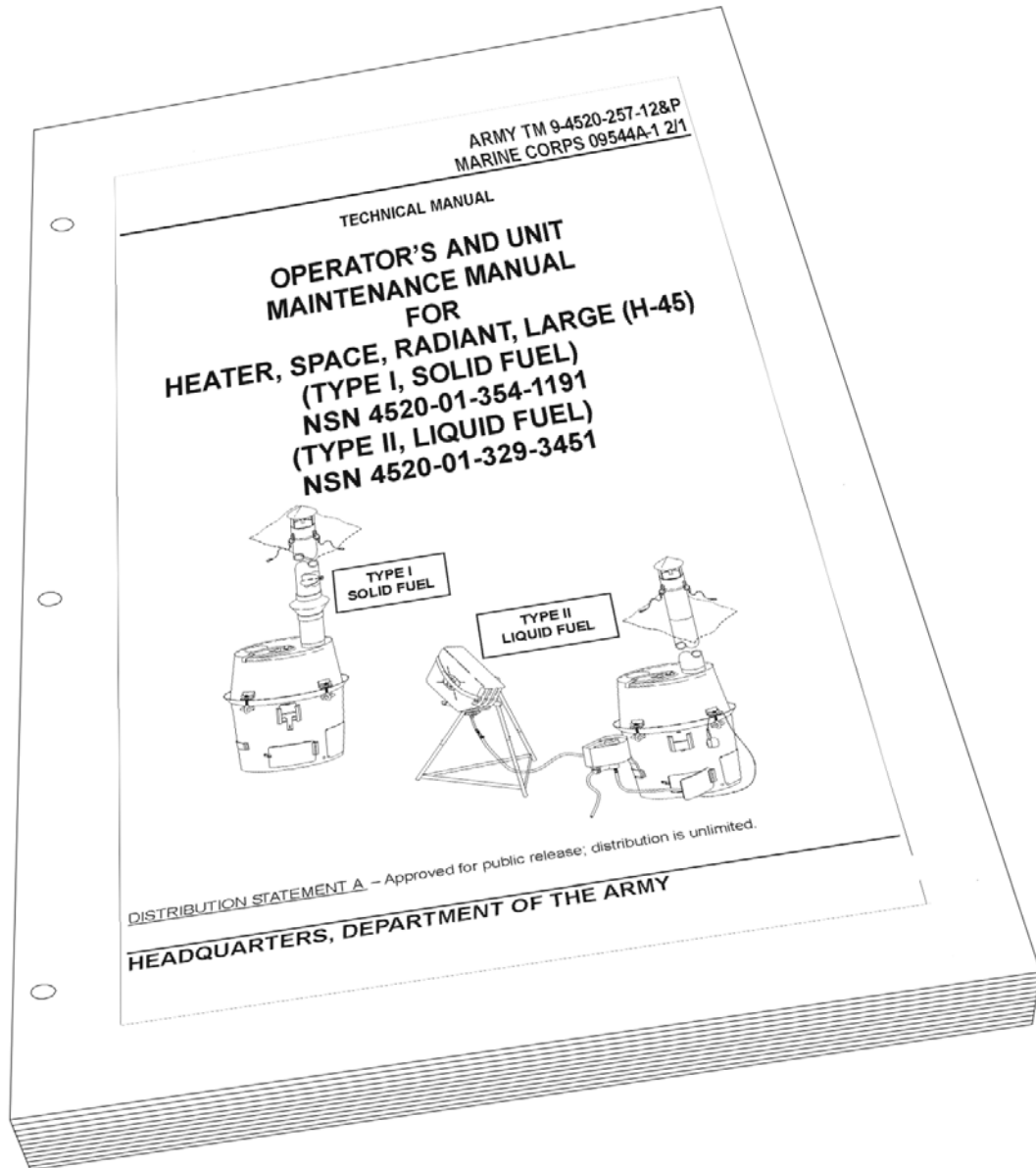

Table 2. Basic Issue Items (BII) List

(1) ILLUS NUMBER	(2) NATIONAL STOCK NUMBER	(3) DESCRIPTION, PART NUMBER AND CAGEC	(4) USABLE ON CODE	(5) U/M	(6) QTY RQR
1	N/A	TM 9-4520-257-12&P		EA	1

END OF WORK PACKAGE

**UNIT MAINTENANCE
H-45 LARGE RADIANT SPACE HEATER
(TYPE 1, SOLID FUEL)
NSN 4520-01-354-1191
H-45 LARGE RADIANT SPACE HEATER
(TYPE II, LIQUID FUEL)
NSN 4520-01-329-3451
ADDITIONAL AUTHORIZATION LIST (AAL)**

INTRODUCTION**Scope**

This section lists additional items authorized for use with the Heater, Space, Radiant, Large (H-45).

General

This list identifies items that are not routinely used with the H-45 and do not have to accompany it or be turned in with it.

Explanation of listing. National Stock Numbers, descriptions, and quantities are provided to help you identify and request the additional items you require to support this equipment. The items are listed in alphabetical sequence by item name.

ADDITIONAL AUTHORIZED LIST ITEMS**Table 1. Additional Authorization List**

(1) NATIONAL STOCK NUMBER	(2) DESCRIPTION, (CAGEC) AND PART NUMBER	(3) USABLE ON CODE	(4) U/M	(5) QTY RECM
7240-01-337-5269	CAN , GASOLINE, MILITARY,CG (81349) CID A-A-59592	FGZ**	EA	1
7240-01-337-5268	CAN, GASOLINE, MILITARY, DT (81349) CID A-A-59592	FGZ**	EA	1
8415-00-227-1220	GLOVES, MEN'S AND WOMEN'S SMALL	FCG*, FGZ**	EA	1
8415-00-227-1221	GLOVES, MEN'S AND WOMEN'S MEDIUM	FCG*, FGZ**	EA	1
8415-00-227-1222	GLOVES, MEN'S AND WOMEN'S LARGE	FCG*, FGZ**	EA	1
4140-01-457-2790	HEATER FAN (81349) MIL-PRF 32001	FCG*, FGZ**	EA	1

END OF WORK PACKAGE

THIS PAGE INTENTIONALLY LEFT BLANK

**UNIT MAINTENANCE
H-45 LARGE RADIANT SPACE HEATER
(TYPE I, SOLID FUEL)
NSN 4520-01-354-1191
(TYPE II, LIQUID FUEL)
NSN 4520-01-329-3451
EXPENDABLE AND DURABLE ITEMS LIST**

INTRODUCTION

This section lists expendable and durable items that you will need to operate and maintain the Heater, Space, Radiant, Large (H-45). This list is for information only and is not authority to requisition the listed items. These items are authorized to you by CTA 50-970, Expendable/Durable Items (Except Medical, Class V Repair Parts, and Heraldic Items), or CTA 8-100, Army Medical Department Expendable/Durable Items.

Explanations of Columns in the Expendable / Durable Items List

Column (1) Item Number. This number is assigned to the entry in the list and is referenced in the narrative instructions to identify the item (such as *Use lubricating oil (WP0047, Table 1, Item 1)*).

Column (2) Level. This column includes the lowest level of maintenance that requires the listed item.

- C** Operator or Crew
- O** Unit Maintenance
- F** Direct Support Maintenance
- H** General Support Maintenance
- D** Depot Maintenance

Column (3) National Stock Number. This is the NSN assigned to the item, which you can use to requisition it.

Column (4) Item Name, Description, CAGEC, and Part Number. This column provides the other information you need to identify the item.

Column (5), U/M (unit of measure). The U/M indicates how the item is issued for the National Stock Number shown in column (1).

EXPENDABLE AND DURABLE ITEMS LIST**Table 1. Expendable and Durable Items List**

(1) ITEM NUMBER	(2) LEVEL	(3) NATIONAL STOCK NUMBER	(4) ITEM NAME, (CAGEC), PART NUMBER	(5) U/M
1	C	7930-01-363-8631	ABSORBANT MATERIAL, OIL AND WATER (1JA49) MAT203	BE
2	O	8030-00-087-8630	ANTISEIZE COMPOUND (81349) MIL-PRF-83483	LB
3	C	5120-00-234-9492	BRUSH, WIRE, FURNACE AND FLUE	EA
4	C		GASKET (92878) 171233	EA
5	C	9150-00-273-2389	LUBRICATING OIL, GENERAL PURPOSE, (81349) MIL-PRF-32033	CN
6	O		PIPE THREAD COMPOUND (92878) 10744	CN
7	C	7920-00-205-3570	RAGS, WIPING (80244)	LB
8	C		VALVE, UMBRELLA (92878) 171236	EA

END OF WORK PACKAGE

THIS PAGE INTENTIONALLY LEFT BLANK

UNIT MAINTENANCE
H-45 LARGE RADIANT SPACE HEATER
 (TYPE I, SOLID FUEL)
 NSN 4520-01-354-1191
 (TYPE II, LIQUID FUEL)
 NSN 4520-01-329-3451
ILLUSTRATED LIST OF MANUFACTURED ITEMS

INTRODUCTION

This work package includes complete instructions for making items authorized to be manufactured or fabricated at unit maintenance level.

All bulk materials needed for manufacture of an item are listed by part number or specification number in a tabular list on the illustration.

STACK CAP ASSEMBLY TENT LINE FABRICATION

Cut braided cotton cord as shown.

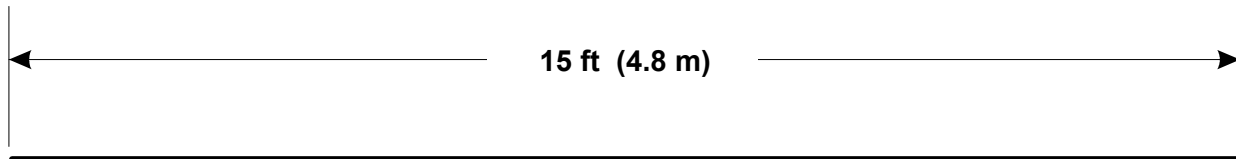

MATERIALS	
DESCRIPTION	PART NO
CORD, COTTON, BRAIDED, .021 DIA	MIL-L-1709, CLASS D, TYPE LIV

END OF WORK PACKAGE

THIS PAGE INTENTIONALLY LEFT BLANK

**OPERATOR AND UNIT MAINTENANCE
H-45 LARGE RADIANT SPACE HEATER
(TYPE I, SOLID FUEL)
NSN 4520-01-354-1191
(TYPE II, LIQUID FUEL)
NSN 4520-01-329-3451
ALPHABETICAL INDEX**

ALPHABETICAL INDEX

A

Abbreviations and Acronyms0001 00-3
Additional Authorization List (AAL)0051 00-1
Assembly and Preparation for Use0005 00-1

B

Basic Issue Items (BI) List.....0050 00-6

C

Capabilities, Characteristics, and Features0002 00-1
Checking Unpacked Equipment.....0009 00-2
Common Tools and Equipment0002 00-7
Components of End Item (COEI) List0050 00-1
Controls and Indicators0004 00-1
Corrosion Prevention and Control (CPC).....0001 00-2

D

Decals and Instruction Plates.....0004 00-5
Description and Use of Operator Controls and Indicators0004 00-1
Description of Major Components.....0002 00-2
Destruction of Army Materiel To Prevent Enemy Use0001 00-2
Differences between H-45 Components by Type0002 00-6
Disassembly and Preparation for Movement (Type I)0005 00-12
Disassembly and Preparation for Movement (Type II)0005 00-32

E

Equipment Characteristics, Capabilities and Features0002 00-1
Equipment Data0002 00-6
Equipment Improvements and Recommendations, Reporting (EIR).....0001 00-2
Expendable and Durable Items List.....0052 00-1
Explanation of Columns in MAC0041 00-2
Explanation of Columns in Remarks.....0041 00-3
Explanation of Columns in Tools and Test Equipment Requirements0041 00-3

F

Forms0040 00-1

G

General Information0001 00-1

H

How to Use this Manualiii

I

Identification Plates and Stencils0004 00-5
 Illustrated List of Manufactured Items0053 00-1
 Introduction to Components Of End Item (COEI) and Basic Issue Items (BI) List0050 00-1
 Introduction to Maintenance Allocation Chart0041 00-1
 Inventory List.....0009 00-1

L

List of Abbreviations/Acronyms.....0001 00-3
 Lubrication Requirements0005 00-35

M

Maintenance Allocation Chart (MAC).....0041 00-4
 Maintenance Forms Records and Reports0001 00-2
 Maintenance Functions0041 00-3
 Maintenance Procedures, Operator.....0012 00-1
 Maintenance Procedures, Unit.....0030 00-1
 Major Components of H-45 Type I (Solid Fuel) Heater0002 00-2
 Major Components of H-45 Type II (Liquid Fuel) Heater0002 00-3
 Malfunction Symptom Index, Operator0007 00-1
 Malfunction Symptom Index, Unit0007 00-1
 Manufactured Items0053 00-1
 Movement, Preparation for H-45 Type I (Solid Fuel) Heater,0005 00-12
 Movement, Preparation for H-45 Type II (Liquid Fuel) Heater,.....0005 00-32

N

National Stock Number Index0047 00-1
 Nomenclature Cross-Reference List.....0001 00-3

O

Operations under Usual Conditions0005 00-1
 Operation in Unusual Environment/Weather Conditions0006 00-1
 Operating Procedures0005 00-1
 Operator Preventative Maintenance Check and Services Procedures0011 00-1

P

Parts List, H-45 Type I (Solid Fuel) Heater	0043 00-1
Parts List, H-45 Type II (Liquid Fuel) Heater	0044 00-1
Part Number Index	0048 00-1
Preparation for Movement, H-45 Type I (Solid Fuel) Heater,	0005 00-12
Preparation for Movement, H-45 Type II (Liquid Fuel) Heater,	0005 00-32
Preventive Maintenance Checks and Services (PMCS), Operator	0011 00-1
Preventive Maintenance Checks and Services (PMCS), Unit	0028 00-1

R

References	0040 00-1
Remarks for H-45	0041 00-6
Repair Parts and Special Tools List, H-45 Type I (Solid Fuel) Heater	0043 00-1
Repair Parts and Special Tools List, H-45 Type II (Liquid Fuel) Heater	0044 00-1
Reporting Equipment Improvement Recommendations (EIRs).....	0001 00-2

S

Safety, Care and Handling, Warnings, Cautions, and Notes	0001 00-4
Service upon Receipt	0009 00-1
Shipment, Preparation for H-45 Type I (Solid Fuel) Heater	0005 00-12
Shipment, Preparation for H-45 Type II (Liquid Fuel) Heater	0005 00-32
Special Tools List	0049 00-1
Starting the H-45 Type I (Solid Fuel) Heater	0005 00-9
Starting the H-45 Type II (Liquid Fuel) Heater	0005 00-24
Stopping the H-45 Type I (Solid Fuel) Heater	0005 00-11
Stopping the H-45 Type II (Liquid Fuel) Heater	0005 00-32
Storage Procedure for H-45 Type I (Solid Fuel) Heater	0005 00-12
Storage Procedure for H-45 Type II (Liquid Fuel) Heater	0005 00-32

T

Table of Contents	i
Technical Manuals	0040 00-1
Theory of Operation	0003 00-1
Tools and Test Equipment Requirements For H-45	0041 00-3
Troubleshooting Procedures, Operator	0008 00-2
Troubleshooting Procedures, Unit	0008 00-4

U

Unit Maintenance Procedures	0030 00-1
Usable On Code	0042 00-4
Unit Preventative Maintenance Check and Services Procedures	0029 00-1

THIS PAGE INTENTIONALLY LEFT BLANK

By Order of the Secretaries of the Army and Navy (including the Marine Corps):

Official:

JOEL B. HUDSON
*Administrative Assistant to the
Secretary of the Army*
0324504

PETER J. SCHOOMAKER
*General, United States Army
Chief of Staff*

D.G. MORRAL
*Rear Admiral, USN
Program Executive Officer
For Expeditionary Warfare
Naval Sea Systems Command*

R.P. SHOCKEY
*Director, Program Support
Marine Corps System Command*

DISTRIBUTION:

To be distributed in accordance with initial distribution number (IDN) 255931 requirements for TM 9-4520-257-12&P.

THIS PAGE INTENTIONALLY LEFT BLANK

These are the instructions for sending an electronic 2028

The following format must be used if submitting an electronic 2028. The subject line must be exactly the same and all fields must be included; however only the following fields are mandatory: 1, 3, 4, 5, 6, 7, 8, 9, 10, 13, 15, 16, 17, and 27.

From: "Whomever" <whomever@avma27.army.mil>

To: amssbriml@natick.army.mil

Subject: DA Form 2028

1. **From:** Joe Smith
2. **Unit:** home
3. **Address:** 4300 Park
4. **City:** Hometown
5. **St:** MO
6. **Zip:** 77777
7. **Date Sent:** 19-OCT-93
8. **Pub no:** 55-2840-229-23
9. **Pub Title:** TM
10. **Publication Date:** 04-JUL-85
11. **Change Number:** 7
12. **Submitter Rank:** MSG
13. **Submitter FName:** Joe
14. **Submitter MName:** T
15. **Submitter LName:** Smith
16. **Submitter Phone:** 123-123-1234
17. **Problem:** 1
18. **Page:** 2
19. **Paragraph:** 3
20. **Line:** 4
21. **NSN:** 5
22. **Reference:** 6
23. **Figure:** 7
24. **Table:** 8
25. **Item:** 9
26. **Total:** 123
27. **Text:**

This is the text for the problem below line 27.

THIS PAGE INTENTIONALLY LEFT BLANK

RECOMMENDED CHANGES TO PUBLICATIONS AND BLANK FORMS For use of this form, see AR 25-30; the proponent agency is ODISC4.						Use Part II (reverse) for Repair Parts and Special Tool Lists (RPSTL) and Supply Catalogs/Supply Manuals (SC/SM).	DATE <i>21 October 2003</i>
TO: (Forward to proponent of publication or form) (Include ZIP Code) COMMANDER U.S. ARMY SOLDIER AND BIOLOGICAL CHEMICAL COMMAND ATTN: AMSSB-RIM-L KANSAS STREET NATICK, MA 01760-5052						FROM: (Activity and location) (Include ZIP Code) <i>PFC Jane Doe</i> <i>CO A 3rd Engineer BR</i> <i>Ft. Leonardwood, MO 63108</i>	
PART I – ALL PUBLICATIONS (EXCEPT RPSTL AND SC/SM) AND BLANK FORMS							
PUBLICATION/FORM NUMBER TM 10-1670-296-23&P				DATE 30 October 2002	TITLE Unit Manual for Ancillary Equipment for Low Velocity Air Drop Systems		
ITEM NO.	PAGE NO.	PARA-GRAPH	LINE NO. *	FIGURE NO.	TABLE NO.	RECOMMENDED CHANGES AND REASON (Provide exact wording of recommended changes, if possible).	
	<i>0036 00-2</i>				<i>1</i>	<p><i>In table 1, Sewing Machine Code Symbols, the second sewing machine code symbol should be MD ZZ not MD 22.</i></p> <p><i>Change the manual to show Sewing Machine, Industrial: Zig-Zag; 308 stitch; medium-duty; NSN 3530-01-181-1421 as a MD ZZ code symbol.</i></p>	
<small>*Reference to line numbers within the paragraph or subparagraph.</small>							
TYPED NAME, GRADE OR TITLE Jane Doe, PFC				TELEPHONE EXCHANGE/AUTOVON, PLUS EXTENSION 508-233-4141		SIGNATURE Jane Doe <i>Jane Doe</i>	

TO: <i>(Forward direct to addressee listed in publication)</i> COMMANDER U.S. ARMY SOLDIER AND BIOLOGICAL CHEMICAL COMMAND ATTN: AMSSB-RIM-L KANSAS STREET NATICK, MA 01760-5052	FROM: <i>(Activity and location) (Include ZIP Code)</i> <i>PFC Jane Doe</i> <i>CO A 3rd Engineer BR</i> <i>Ft. Leonardwood, MO 63108</i>	DATE 21 October 2003
--	---	--------------------------------

PART II – REPAIR PARTS AND SPECIAL TOOL LISTS AND SUPPLY CATALOGS/SUPPLY MANUALS

PUBLICATION NUMBER TM 10-1670-296-23&P	DATE 30 October 2002	TITLE Unit Manual for Ancillary Equipment for Low Velocity Air Drop Systems
--	--------------------------------	---

PAGE NO.	COLM NO.	LINE NO.	NATIONAL STOCK NUMBER	REFERENCE NO.	FIGURE NO.	ITEM NO.	TOTAL NO. OF MAJOR ITEMS SUPPORTED	RECOMMENDED ACTION
0066 00-1					4			<i>Callout 16 in figure 4 is pointed to a <u>D-Ring</u>. In the Repair Parts List key for figure 4, item 16 is called a <u>Snap Hook</u>. Please correct one or the other.</i>

PART III – REMARKS *(Any general remarks or recommendations, or suggestions for improvement of publications and blank forms. Additional blank sheets may be used if more space is needed.)*

--	--	--

TYPED NAME, GRADE OR TITLE	TELEPHONE EXCHANGE/AUTOVON, PLUS EXTENSION	SIGNATURE
----------------------------	--	-----------

RECOMMENDED CHANGES TO PUBLICATIONS AND BLANK FORMS For use of this form, see AR 25-30; the proponent agency is ODISC4.						Use Part II (reverse) for Repair Parts and Special Tool Lists (RPSTL) and Supply Catalogs/Supply Manuals (SC/SM).	DATE
TO: (Forward to proponent of publication or form) (Include ZIP Code)						FROM: (Activity and location) (Include ZIP Code)	
PART I – ALL PUBLICATIONS (EXCEPT RPSTL AND SC/SM) AND BLANK FORMS							
PUBLICATION/FORM NUMBER TM 9-4520-257-12&P				DATE 30 September 2003		TITLE Operator and Unit Maintenance Manual (Including Repair Parts and Special Tools List (RPSTL)) for Heater, Space, Radiant, Large (H-45)	
ITEM NO.	PAGE NO.	PARA-GRAPH	LINE NO. *	FIGURE NO.	TABLE NO.	RECOMMENDED CHANGES AND REASON <i>(Provide exact wording of recommended changes, if possible).</i>	
<i>*Reference to line numbers within the paragraph or subparagraph.</i>							
TYPED NAME, GRADE OR TITLE				TELEPHONE EXCHANGE/AUTOVON, PLUS EXTENSION		SIGNATURE	

TO: (Forward direct to addressee listed in publication)				FROM: (Activity and location) (Include ZIP Code)				DATE	
PART II – REPAIR PARTS AND SPECIAL TOOL LISTS AND SUPPLY CATALOGS/SUPPLY MANUALS									
PUBLICATION NUMBER TM 9-4520-257-12&P				DATE 30 September 2003			TITLE Operator and Unit Maintenance Manual (Including Repair Parts and Special Tools List (RPSTL)) for Heater, Space, Radiant, Large (H-45)		
PAGE NO.	COLM NO.	LINE NO.	NATIONAL STOCK NUMBER	REFERENCE NO.	FIGURE NO.	ITEM NO.	TOTAL NO. OF MAJOR ITEMS SUPPORTED	RECOMMENDED ACTION	
PART III – REMARKS (Any general remarks or recommendations, or suggestions for improvement of publications and blank forms. Additional blank sheets may be used if more space is needed.)									
TYPED NAME, GRADE OR TITLE				TELEPHONE EXCHANGE/AUTOVON, PLUS EXTENSION			SIGNATURE		

The Metric System and Equivalents

Linear Measure

1 centimeter = 10 millimeters = .39 inch
 1 decimeter = 10 centimeters = 3.94 inches
 1 meter = 10 decimeters = 39.37 inches
 1 dekameter = 10 meters = 32.8 feet
 1 hectometer = 10 dekameters = 328.08 feet
 1 kilometer = 10 hectometers = 3,280.8 feet

Weights

1 centigram = 10 milligrams = .15 grain
 1 decigram = 10 centigrams = 1.54 grains
 1 gram = 10 decigrams = .035 ounce
 1 dekagram = 10 grams = .35 ounce
 1 hectogram = 10 dekagrams = 3.52 ounces
 1 kilogram = 10 hectograms = 2.2 pounds
 1 quintal = 100 kilograms = 220.46 pounds
 1 metric ton = 10 quintals = 1.1 short tons

Liquid Measure

1 centiliter = 10 milliliters = .34 fl. ounce
 1 deciliter = 10 centiliters = 3.38 fl. ounces
 1 liter = 10 deciliters = 33.81 fl. ounces
 1 dekaliter = 10 liters = 2.64 gallons
 1 hectoliter = 10 dekaliters = 26.42 gallons
 1 kiloliter = 10 hectoliters = 264.18 gallons

Square Measure

1 sq. centimeter = 100 sq. millimeters = .155 sq. inch
 1 sq. decimeter = 100 sq. centimeters = 15.5 sq. inches
 1 sq. meter (centare) = 100 sq. decimeters = 10.76 sq. feet
 1 sq. dekameter (are) = 100 sq. meters = 1,076.4 sq. feet
 1 sq. hectometer (hectare) = 100 sq. dekameters = 2.47 acres
 1 sq. kilometer = 100 sq. hectometers = .386 sq. mile

Cubic Measure

1 cu. centimeter = 1000 cu. millimeters = .06 cu. inch
 1 cu. decimeter = 1000 cu. centimeters = 61.02 cu. inches
 1 cu. meter = 1000 cu. decimeters = 35.31 feet

Approximate Conversion Factors

<i>To change</i>	<i>To</i>	<i>Multiply by</i>	<i>To change</i>	<i>To</i>	<i>Multiply by</i>
inches	centimeters	2.540	ounce-inches	newton-meters	.007062
feet	meters	.305	centimeters	inches	.394
yards	meters	.914	meters	feet	3.280
miles	kilometers	1.609	meters	yards	1.094
square inches	square centimeters	6.451	kilometers	miles	.621
square feet	square meters	.093	square centimeters	square inches	.155
square yards	square meters	.836	square meters	square feet	10.764
square miles	square kilometers	2.590	square meters	square yards	1.196
acres	square hectometers	.405	square kilometers	square miles	.386
cubic feet	cubic meters	.028	square hectometers	acres	2.471
cubic yards	cubic meters	.765	cubic meters	cubic feet	35.315
fluid ounces	milliliters	29.573	cubic meters	cubic yards	1.308
pints	liters	.473	milliliters	fluid ounces	.034
quarts	liters	.946	liters	pints	2.113
gallons	liters	3.785	liters	quarts	1.057
ounces	grams	28.349	liters	gallons	.264
pounds	kilograms	.454	grams	ounces	.035
short tons	metric tons	.907	kilograms	pounds	2.205
pound-feet	newton-meters	1.356	metric tons	short tons	1.102
pound-inches	newton-meters	.11296			

Temperature (Exact)

_F	Fahrenheit temperature	5/9 (after subtracting 32)	Celsius temperature	_C
----	---------------------------	-------------------------------	------------------------	----

PIN: 070472-000