



2-IN-1 CARGO CARRIER AND BIKE RACK OWNER'S MANUAL



Model # TTF-2762KR



WARNING:

Read carefully and understand all **ASSEMBLY AND OPERATION INSTRUCTIONS** before operating. Failure to follow the safety rules and other basic safety precautions may result in serious personal injury.

Thank you very much for choosing the Product! For future reference, please complete the owner's record below:

Model: _____ Purchase Date: _____

Save the receipt, warranty and these instructions. It is important that you read the entire manual to become familiar with this product before you begin using it.

This product is designed for certain applications only. The distributor cannot be responsible for issues arising from modification. We strongly recommend this product not be modified and/or used for any application other than that for which it was designed. If you have any questions relative to a particular application, DO NOT use this product until you have first contacted the distributor to determine if it can or should be performed on the product.

For technical questions, please call **1-218-943-6296**

Technical Specifications

Carrier dimensions	62in. x 27in. (157 x 69cm)
Load Weight Capacity	500-lb. including carrier weight (Class III receiver) 350-lb. including carrier weight (Class II receiver)
Required Receiver	2 in.

IMPORTANT SAFETY INSTRUCTIONS

Safety Warnings and Precautions



WARNING: When using product, basic safety precautions should always be followed to reduce the risk of personal injury and damage to equipment.

Read all instructions before using this product!

1. **Keep work area clean.** Cluttered areas invite injuries.
2. **Observe work area conditions.** Keep work area well lighted.
3. **Store idle equipment.** When not in use, the Carrier must be stored in a safe and clean location. Always lock up products and keep out of reach of children.
4. **Use the right product for the job.** There are certain applications for which the Cargo Carrier was designed. Do not modify the Cargo Carrier and do not use the Cargo Carrier for a purpose for which it was not intended.
5. **Check for damaged parts.** Before using any product, any part that appears damaged should be carefully checked to determine that it will operate properly and perform its intended function. Check for any broken or damaged parts and any other conditions that may affect its operation. Replace or repair damaged or worn parts immediately.
6. **Replacement parts and accessories.** When servicing, use only identical replacement parts. Use of any other parts will void the warranty.
7. **Do not exceed the product's maximum load capacity of 500 lbs.**
8. **Only use the Cargo Carrier with a properly installed 2 inch hitch receiver capable of supporting the Cargo Carrier and its load. If the Cargo Carrier is installed on a class II receiver, total weight, including carrier, is limited to 350 lbs.**

9. **Use eye protection.** Always wear ANSI approved impact safety goggles when setting up, loading and unloading the Cargo Carrier. **Wear gloves and avoid sharp edges when assembling and when loading and unloading the Cargo Carrier.**
10. **Do not allow children to play on, stand upon or climb into the Cargo Carrier.** The Cargo Carrier is not for carrying people or animals.
11. **Always check hardware and assembled parts after assembling.** All connections should be tight and hardware tightened.
12. **Always distribute objects in the Cargo Carrier evenly.** Uneven weight distribution could cause tipping.
13. **Be aware of dynamic loading!** Suddenly dropping or bouncing a load on the Cargo Carrier may create, for a brief instant, an excess load, which may result in damage to the product and/or personal injury. Additionally, if the vehicle hits a bump, a slight play in the receiving hitch or a movement in the load could result in a momentary dynamic loading effect that could dramatically increase the actual weight load. Check the hitch-to-carrier connection for any looseness. This momentary dynamic loading effect could result in damage to the Cargo Carrier, the load and possible personal injury.
14.  **WARNING:** Be aware of the possible risk of fire and damage to property resulting from the vehicle's exhaust system pointing at or running near the cargo loaded on the Cargo Carrier. Before installing the Cargo Carrier, check to make sure that the exhaust pipe is not pointing in the direction of the cargo. Flammable cargo can ignite from exposure to heat. Other cargo can be damaged from the heat. Always be aware of this potential danger, and never use the Cargo Carrier if the risk exists.
15. **Follow DOT guidelines for installation and use.**
16. **Do not exceed 65 MPH while carrier is attached.**

 **WARNING:** The warnings, cautions, and instructions discussed in this instruction manual cannot cover all possible conditions and situations that may occur. It must be understood by the operator that common sense and caution are factors which cannot be built into this product, but must be supplied by the operator.

IMPORTANT SAFETY INFORMATION FOR BIKE RACK

1. The bike rack is used as a stabilizing support only.
2. All bikes **MUST** be tied down with straps and/or secured with a chain.
3. Check all hardware connections (nuts & bolts) before each use.
4. Bike Rack is designed to carry most bikes or small motor bikes where the wheels fit inside the cradle arms.
5. For added security, use a locking bike chain.

Assembly for Cargo Carrier

It is important that you read the entire manual to become familiar with the product BEFORE you assemble and use the Cargo Carrier. Before assembling and operating the Cargo Carrier, be sure that you have all parts described in the Parts List and Assembly Diagram located on the last pages of this manual.

See part diagram for reference:

1. Place both halves of the Platform (6) together. Place the Top Brace (12) on the top center of the Platform Assembly. Be sure to align the corner holes on the Top Brace (12) and corresponding holes on the Platform (6). Secure them with four Bolts (7) and four Lock Nuts (9). Hand tighten.

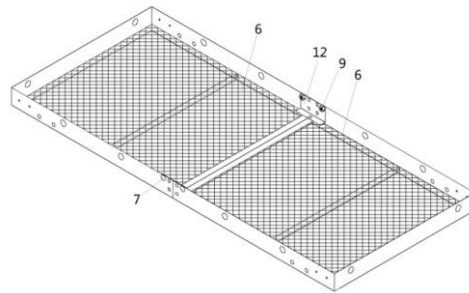

2. Put the Platform Assembly onto the 2 in. Square Tube (13). Place the Support Bridges (8) down the 2 in. Square Tube (13), align the holes on the above parts.

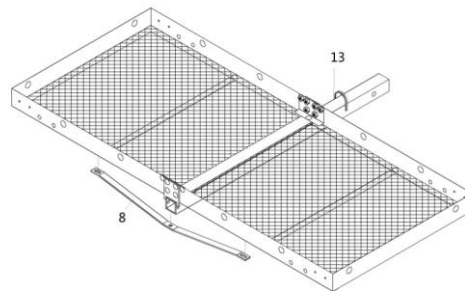

3. Connect the Top Brace (12), the Platform Assembly, the 2 in. Square Tube (13) and the Support Bridges (8) with eight Bolts (7), two Bolts (11) and ten Lock Nuts (9). Hand Tighten.

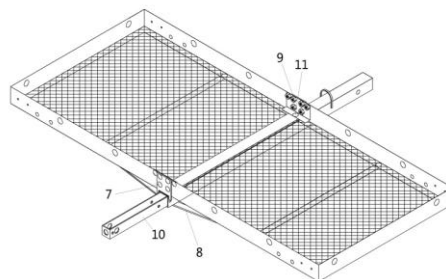

4. Connect the Platform Assembly and Support Bridges (8) with four Bolts (7) and four Lock Nuts (9). Hand Tighten.

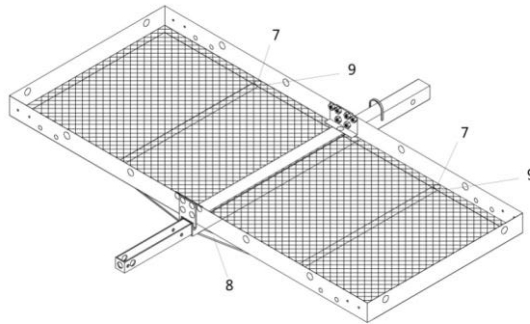

5. Align the Platform Assembly to be level, and then tighten down all the Bolts and Lock Nuts.
6. Attach the two Reflectors (17) onto the back side rail of the Platform Assembly using two Spring Washers (18) and two Nuts (19).

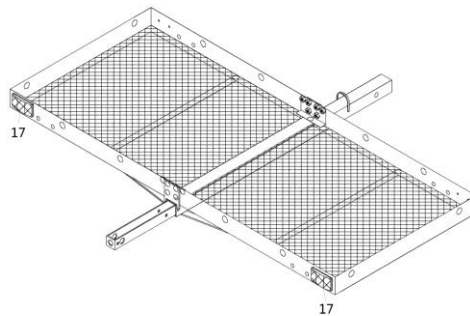

Assembly for Bike Rack

1. Place three the Bike Rack Runners (2) and one Off-Set Bike Rack Runner (3) in line on one side of the Platform (6). Slide the Long Shaft (4) through the mounting holes on the Platform (6), holes on the Bike Rack Runners (2) and the Off-Set Bike Rack Runner (3). Secure the Long Shaft (4) in place with four R-pin (5).
2. Repeat the above step on the opposite side of the Platform (6). Be sure the offset Bike Rack Runners (3) are in the same position.

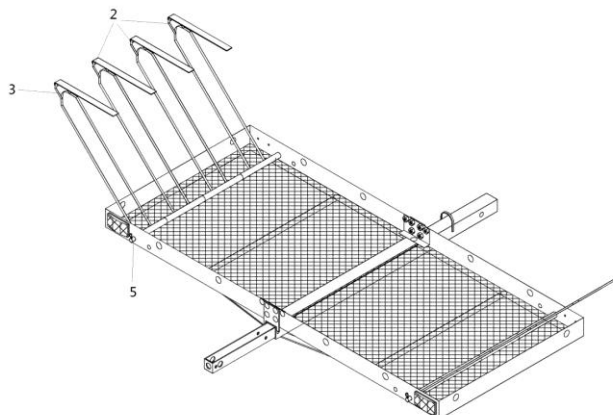

3. Insert the Tie down Bracket (10) into the 2in. Square Tube (13) from back end and secure them with Pin (14) and one R-pin (5).

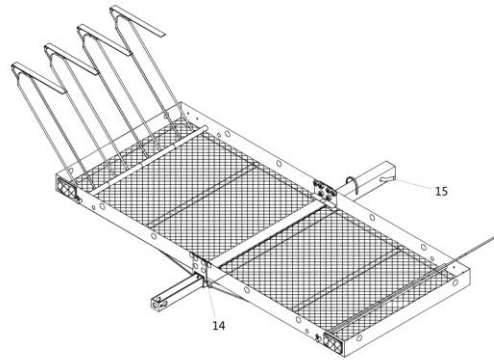

Operation

 **WARNING:** The load weight must be centered or evenly distributed across the Carrier platform. Always use appropriate tie-down restraints to securely attach any cargo loaded onto the Cargo Carrier before moving your vehicle any distance. Do not leave loose items on the platform while operating the vehicle. Always use Reflectors. Make certain to use the appropriate red flags when moving a load. Check with your local traffic enforcement agency to make certain that you are correctly following all local laws.

- a) Find the assistance of another adult to help lift the Cargo Carrier.
- b) Lift the Cargo Carrier and place the 2 in. Square Tube (13) into the 2 in. Hitch Receiver mounted to your vehicle.
- c) Line up the hole in the 2 in. Square Tube (13) with the hole in your hitch. With the holes lined up, slide a Hitch Pin (15) through the holes and insert a Lock Pin (16).
- d) Put down all Bike Rack Runners down on the Platform Assembly.

Your Cargo Carrier can be loaded with up to 500 lb. of evenly distributed cargo **if an appropriately rated hitch is used.**

 **WARNING:** The load weight must be centered or evenly distributed across the Carrier platform. Always use appropriate tie-down restraints to securely attach any cargo loaded onto the Cargo Carrier before moving your vehicle any distance. Do not leave loose items on the platform while operating the vehicle.

Note: Any load over 320 lb. requires a Class 3 hitch on the vehicle.
(Class 2 Hitch = 350 lb. maximum tongue weight, add Carrier weight of about 30 lb.)
(Class 3 Hitch = 500 lb. maximum tongue weight)

Always use Reflectors. Make certain to use the appropriate red flags when moving a load. Check with your local traffic enforcement agency to make certain that you are correctly following all local laws.

Operation as a Bike Carrier

1. Before each use, ensure all bolts are secured tightly.
2. Remove the Pin (14) and R-pin (15) and pull Tie down Bracket (10) out a bit, then replace the Pin (14) and R-pin (15).
3. Tip the Bike Rack Runners to make sure they slant toward the outside of the vehicle.
4. Place the wheels of bike into the Bike Rack Runners and secure the wheels with Magic Straps (1).
5. When all bikes are in place and secure, weave tie-down straps through the bike frames and lock into place.

MAINTENANCE

- **Maintain your cargo and bike carrier.** It is recommended that the general condition of the carrier be examined before it is used. Check all nuts and bolts to make sure they are tightened on a regular basis as part of a maintenance schedule. If you hear any abnormal vibrations or noise, have the problem corrected before further use. Have necessary repairs made by qualified service personnel.

Parts and Assembly Diagram

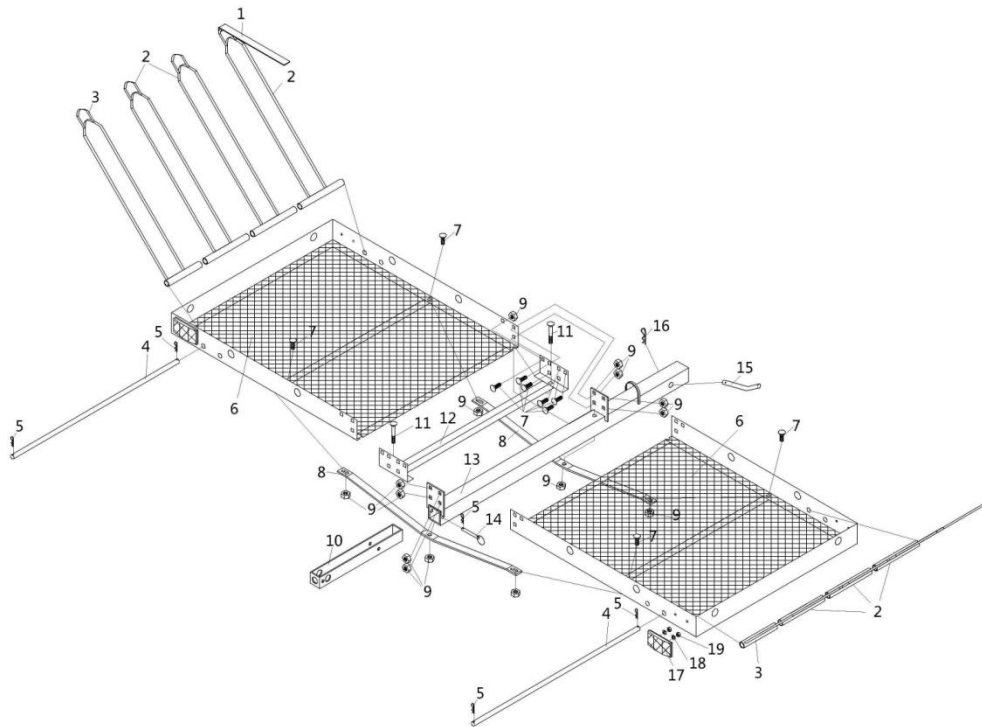

Part	Description	Qty.	Part	Description	Qty.
1	Magic Strap	8	11	Bolt	2
2	Bike Rack Runner	6	12	Top Brace	1
3	Off-Set Bike Rack Runner	2	13	2 in. Square Tube	1
4	Long Shaft	2	14	Pin	1
5	R-pin	5	15	Hitch Pin	1
6	Carrier Platform	2	16	Lock Pin	1
7	Bolt	16	17	Reflector	2
8	Support Bridge	2	18	Spring Washer	4
9	Lock Nut	18	19	Nut	4
10	Tie down Bracket	1			

For technical questions, please call **1-218-943-6296**

WARRANTY: One-year Limited Parts Warranty



Dist by:
PO Box 203
Miltona, MN 56354

Made in China