

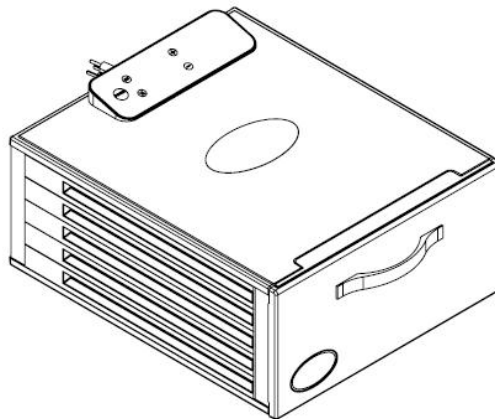

Guide Gear 5 Tray Food Dehydrator

Owner's Manual



! **WARNING:** Read carefully and understand all ASSEMBLY AND OPERATION INSTRUCTIONS before operating. Failure to follow the safety rules and other basic safety precautions may result in serious personal injury.

Item # 1A-DS113

READ & SAVE THESE INSTRUCTIONS

Congratulations on your Guide Gear™ purchase.

Take your game to the next level with field-tested Guide Gear™ products for a confident, competitive edge that strikes the perfect balance between performance and value.

For future reference, please complete the owner's record below:

Serial Number/Lot Date Code: _____

Purchase Date: _____

Save the receipt, warranty, and this manual. It is important that you read the entire manual to become familiar with this product before you begin using it.

This food dehydrator is designed for certain applications only. The Sportsman's Guide and Northern Tool and Equipment are not responsible for issues arising from modification or improper use of this product such as an application for which it was not designed. We strongly recommend that this product not be modified and/or used for any application other than that for which it was designed.

DO NOT RETURN TO THE STORE.

For help with assembly, service, or missing/defective parts,

Please call our toll-free number:

1-800-545-9633

Or email:

customerservice@forcome.com

M-F 8:00 AM - 6:00 PM CST

Saturday 8:00 AM - 4:00 PM CST

Table of Contents

Intended Use	4
Technical Specifications	4
Important Safety Information	4
Specific Operation Warnings	6
Grounding	7
Extension Cords	8
Main Parts of the Food Dehydrator	9
Food Dehydrator Control Panel Diagram	11
Before Each Use	12
Operating Instructions	12
Food Drying Guides	13
Tips to Obtain the Best Results	15
Pre-Treatment of Foods	15
Making and Storing Jerky	16
Fruit Roll-Ups	17
Drying Flowers and Crafts	17
Reconstituting Dried Foods	18
Recipes	18
Food Safety	19
Problem Solving and Troubleshooting	20
Cleaning and Maintenance	21
Replacement Parts	21
Limited Warranty	22

Intended Use

Turn to this Guide Gear® Food Dehydrator to make high quality foods such as venison jerky, dehydrated freshly picked vegetables from your garden, and fruit leather. This 5 tray dehydrator is intended for household use only. You can also use it to make certain crafts, such as drying flowers, dough art and beads.

Technical Specifications

Property	Specification
5 Tray H.D. Food Dehydrator 1A-DS113	120V 60HZ 550W
Control Type	Digital LED
Dehydrator Body Construction	Food Grade, Shatterproof ABS Plastic
Weight	17 Pounds
Dimensions	21" x 16.5" x10"
Thermostat Range	85 to 155 Degrees Fahrenheit

Important Safety Information

WARNING

- Read and understand all instructions. Failure to follow all instructions may result in serious injury or property damage.
- The warnings, cautions, and instructions in this manual cannot cover all possible conditions or situations that could occur. Exercise common sense and caution when using this food dehydrator. Always be aware of the environment and ensure that the food dehydrator is used in a safe and responsible manner.
- Do not allow persons to operate or assemble the food dehydrator until they have read this manual and have developed a thorough understanding of how it works.
- Do not modify this food dehydrator in any way. Unauthorized modification may impair the function and/or safety and could affect the life of the product. There are specific applications for which the product was designed.
- Use the right food dehydrator for the job. DO NOT attempt to force small equipment to do the work of larger industrial equipment. There are certain applications for which this food dehydrator was designed. This food dehydrator will be safer and do a better job at the capacity for which it was intended. DO NOT use this food dehydrator for a purpose for which it was not intended.
- Industrial or commercial applications must follow OSHA requirements.

WARNING

WORK AREA SAFETY

- Inspect the work area before each use. Keep work area clean, dry, free of clutter, and well-lit. Cluttered, wet, or dark work areas can result in injury.
- Do not allow the product to come into contact with an electrical source. The food dehydrator is not insulated and contact will cause electrical shock.
- Keep children and bystanders away from the work area while operating the food dehydrator. Do

not allow children to handle the product.

- Be aware of all power lines, electrical circuits, water pipes, and other mechanical hazards in your work area. Some of these hazards may be hidden from your view and may cause personal injury and/or property damage if contacted.

WARNING

PERSONAL SAFETY

- Stay alert, watch what you are doing, and use common sense when operating the food dehydrator. Do not use the food dehydrator while you are tired or under the influence of drugs, alcohol, or medication. A moment of inattention while operating the food dehydrator may result in serious personal injury.
- Dress properly. Do not wear loose clothing, dangling objects, or jewelry. Keep your hair, clothing and gloves away from moving parts. Loose clothes, jewelry, or long hair can be caught in moving parts. Air vents on the food dehydrator often cover moving parts and should be avoided.
- Wear the proper personal protective equipment when necessary. Use ANSI Z87.1 compliant safety goggles (not safety glasses) with side shields, or when needed, a face shield. This applies to all persons in the work area.
- Do not overreach. Keep proper footing and balance at all times.
- Do not use the food dehydrator when tired or under the influence of drugs, alcohol or medication.

CAUTION

PRODUCT USE AND CARE.

- Check for damaged parts before each use. Carefully check that the product will operate properly and perform its intended function. Replace damaged or worn parts immediately. Never operate the product with a damaged part.
- Do not use a product with a malfunctioning switch. Any power food dehydrator that cannot be controlled with the power switch is dangerous and must be repaired by an authorized service representative before using.
- Disconnect the power supply from the product and place the switch in the off position before making any adjustments, changing accessories, cleaning or storing the food dehydrator. Such preventive safety measures reduce the risk of starting the food dehydrator accidentally. Allow to cool before putting on or taking off parts.
- Store the product when it is not in use. Store it unplugged in a dry, secure place out of the reach of children. Inspect the food dehydrator for good working condition prior to storage and before re-use.
- Use only accessories that are recommended by the manufacturer for use with your product. Accessories that may be suitable for one food dehydrator may create a risk of injury when used with another food dehydrator.
- Do not leave the food dehydrator running unattended.

Specific Operation Warnings

WARNING

- This unit gets hot. Do not touch metal surfaces while operating.
- Do not touch hot surfaces. Use handles or knobs.
- This unit may scratch household surfaces. Edges may be sharp.
- Do not use sharp utensils inside the unit.
- Do not attempt to move this unit while it is operating.
- Extreme caution must be used when moving an appliance containing hot oil or other hot liquids.
- The distance between dehydrator's back/side and wall/obstacles should be greater than 4 inches. Use in a well ventilated area.
- Never open the rear panel of the food dehydrator. Never remove the back screen from the dehydrator.
- Avoid contact with moving parts.
- Do not operate food dehydrator on flammable surfaces.
- Never put the food dehydrator near a hot burner, in an oven, or in a dishwasher. Food dehydrator parts are not dishwasher safe.
- Do not use food dehydrator outdoors. This food dehydrator is intended for household use only. Do not operate around any flammable or combustible materials.
- Do not let cord hang over the edge of a table or counter, come into contact with sharp edges, or touch hot surfaces. Do not let cord become kinked.
- It is suggested not to use extension cords with this food dehydrator.
- Place the food dehydrator on a firm and stable surface away from the edge of the worktop. Never use the food dehydrator unless it is fully upright and completely assembled. All four feet should be secure on a level surface. The food dehydrator should not move during operation.
- To avoid unintentional starting, make sure the power switch is in the "OFF" position before connecting the dehydrator to the power source.
- Do not use in wet areas. Do not put food dehydrator in water or other liquids. Do not operate food dehydrator with wet hands or while standing on a wet floor. Do not use food dehydrator if it is wet.
- Use only indoors, in a clean, dry location, free of flammable objects.
- Never plug unit into a damaged electrical outlet.
- Always attach plug to appliance first, then plug cord into the wall outlet. To disconnect, turn any control to "off", then remove plug from wall outlet.
- Clean food dehydrator to instructions. Clean with a damp cloth and mild detergent. Make sure food dehydrator is completely dry before reconnecting to a power source, if not electric shock may result.

Grounding

WARNING

- This food dehydrator must be grounded while in use to protect the operator from electrical shock. This unit is equipped with an electrical cord that has an equipment grounding conductor and a grounding plug. The plug **MUST** be plugged into a matching receptacle that is properly installed and grounded in accordance with ALL local codes and ordinances.
- **DO NOT MODIFY THE PROVIDED PLUG.** If it will not fit the receptacle, have the proper receptacle installed by a qualified electrician.
- **CHECK** with a qualified electrician or service person if you do not completely understand the grounding instructions, or if you are not sure the food dehydrator is properly grounded.

Grounded Food Dehydrators: Food Dehydrators with 3-Prong Plugs

Food dehydrators marked with **Grounding Required** have a 3-wire cord and 3-prong grounding plug. The plug must be connected to a properly grounded outlet. If the food dehydrator should electrically malfunction or break down, grounding provides a low resistance path to carry electricity away from the user, reducing the risk of electric shock. (See Figure A.)

The grounding prong in the plug is connected through the green wire inside the cord to the grounding system in the food dehydrator. The green wire in the cord must be the only wire connected to the food dehydrator's grounding system and must never be attached to an electrically live terminal.

Your food dehydrator must be plugged into an appropriate outlet, properly installed and grounded in accordance with all codes and ordinances. The plug and outlet should look like those in the following illustration.

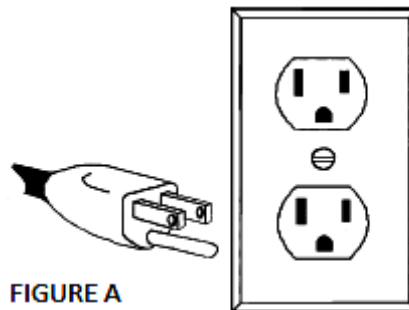

Double Insulated Food Dehydrators: Food Dehydrators with Two-Prong Plugs

Food dehydrators marked **Double Insulated** do not require grounding. They have a special double insulation system which satisfies OSHA requirements and complies with the applicable standards of Underwriters Laboratories, Inc., the Canadian Standard Association, and the National Electrical Code. (See Figure B.)

Double insulated food dehydrators may be used in either of the 120 volt outlets shown in the following illustration.

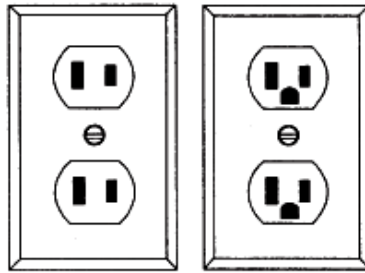

FIGURE B

Extension Cords

⚠ WARNING

- It is recommended that you do not use an extension cord with this food dehydrator.
 - If you do, USE A PROPER EXTENSION CORD. Make sure your extension cord is in good condition. When using an extension cord, be sure to use one heavy enough to carry the current your product will draw. An undersized cord will cause a drop in line voltage, resulting in loss of power and cause overheating.
 - Be sure your extension cord is properly wired and in good condition. Always replace a damaged extension cord or have it repaired by a qualified person before using it. Protect your extension cords from sharp objects, excessive heat and damp or wet areas.
-
- Grounded food dehydrators require a 3-wire extension cord. Double Insulated food dehydrators can use either a 2- or 3-wire extension cord.
 - As the distance from the supply outlet increases, you must use a heavier gauge extension cord. Using extension cords with inadequately sized wire causes a serious drop in voltage, resulting in loss of power and possible food dehydrator damage.
 - The smaller the gauge number of the wire, the greater the capacity of the cord. For example, a 14-gauge cord can carry a higher current than a 16-gauge cord. Minimum extension cord wire size is shown in the following table:

Minimum Wire Size Of Extension Cords				
Nameplate AMPS	Cord Length			
	25'	50'	100'	150'
0-6	18 AWG	16 AWG	16 AWG	14 AWG
6-10	18 AWG	16 AWG	14 AWG	12 AWG
10-12	16 AWG	16 AWG	14 AWG	12 AWG
12-16	14 AWG	12 AWG	NOT RECOMMENDED	

- When using more than one extension cord to make up the total length, make sure each cord contains at least the minimum wire size required.
- If you are using one extension cord for more than one food dehydrator, add the nameplate amperes and use the sum to determine the required minimum cord size.
- Make sure your extension cord is properly wired and in good electrical condition. Always replace a damaged extension cord or have it repaired by a qualified electrician before using it.
- Protect your extension cords from sharp objects, excessive heat, and damp or wet areas.

Main Parts of the Food Dehydrator

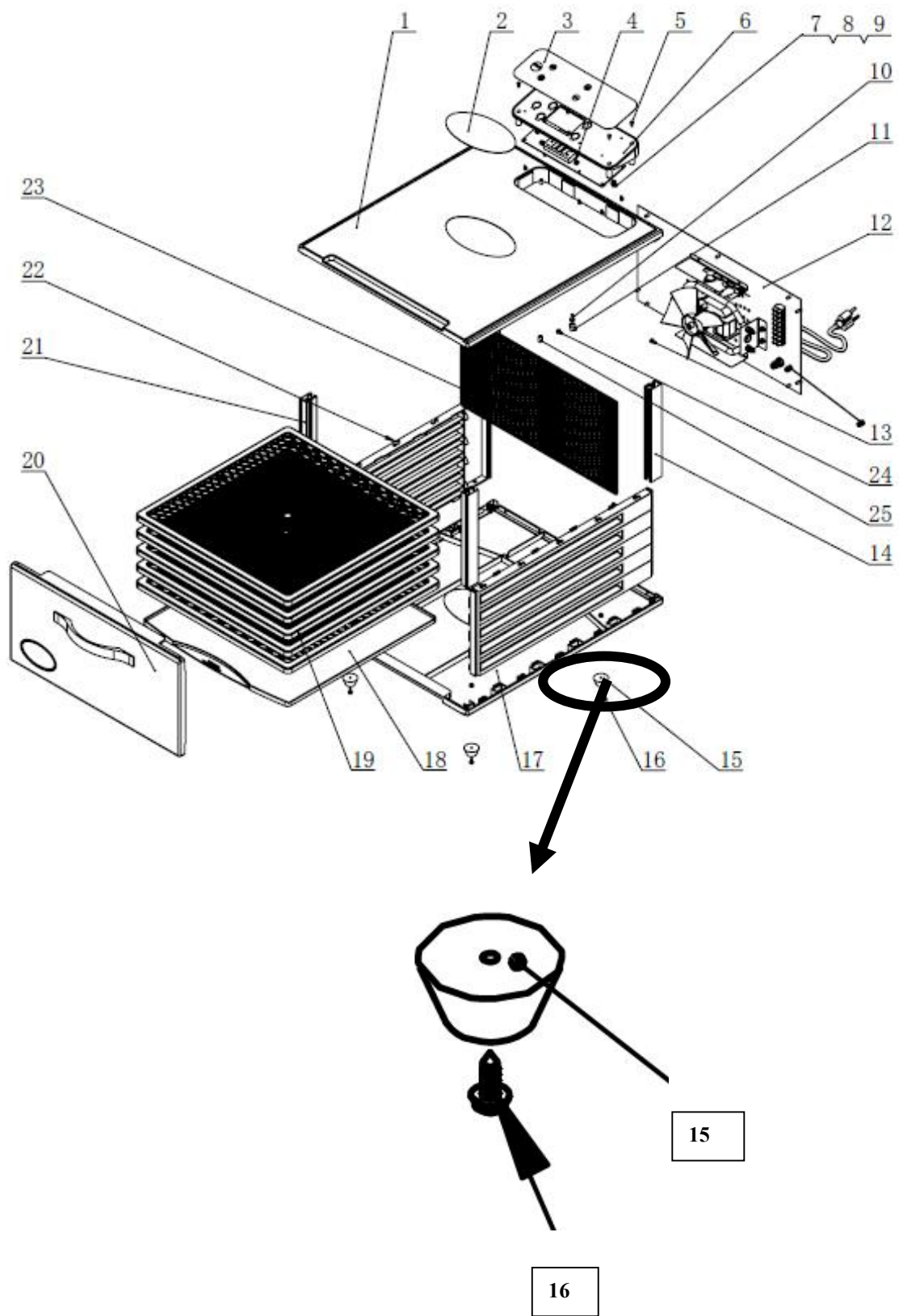

NO.	PART DESCRIPTION	QTY
1	Top Board	1
2	LOGO Plate	1
3	Label of Control Board	1
4	Control Circuit Board	1
5	Pan Head Self-drilling Screw	10
6	Cover of Circuit	1
7	Washer 4	3
8	Spring Washer 4	2
9	Hex Nut	2
10	Pan Head Screw M4*10	1
11	R Clip	1
12	Rear Board Assembly	1
13	Pan Head Self-drilling Screw ST4*8	18
14	Back Aluminum Corner Frame	2
15	Rubber Feet	4
16	Pan Head Self-drilling Screw ST3*10	4
17	Bottom Board	1
18	Oil pans	1
19(a)	Tray (5 tray dehydrator)	5
19(b)	Tray (10 tray dehydrator)	10
20	Door Assembly	1
21	Front Aluminum Corner Frame	2
22(a)	Side Board (5 tray dehydrator)	2
22(b)	Side Board (10 tray dehydrator)	4
23	Wire Partition	1
24	Pan Head Screw M4*20	1
25	Through Isolation Column	1

Food Dehydrator Control Panel Diagram

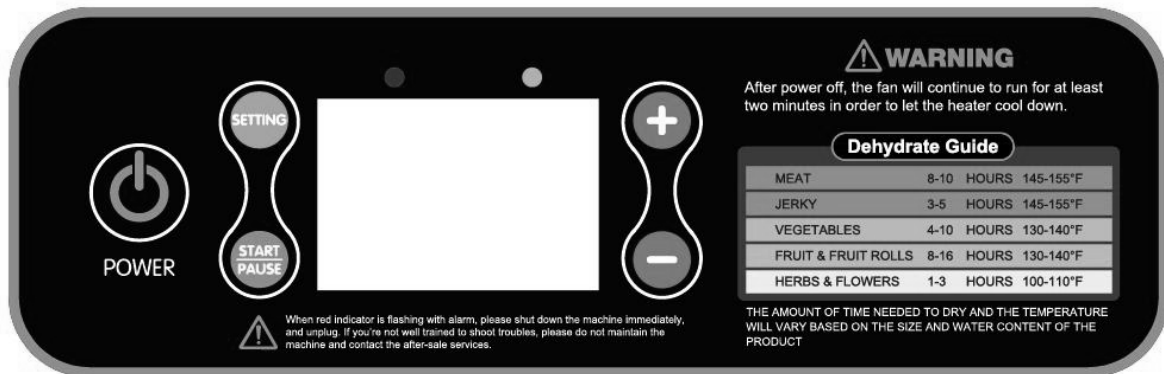

Red Alarm Light

Green Running Light

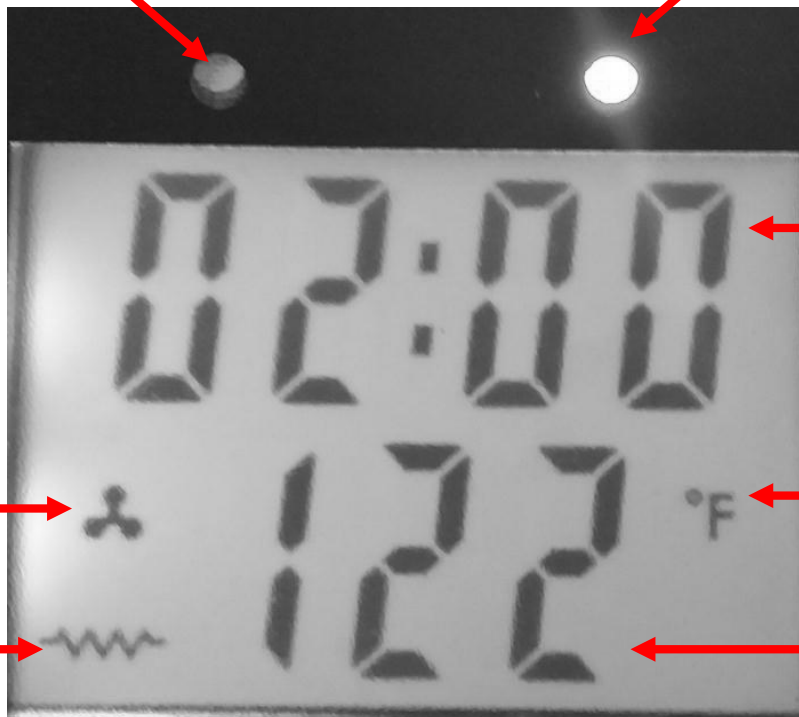

Time

Temperature Unit

Temperature

Work Fan

Heat Wire

Before Each Use

WARNING

- Wash and dry all parts thoroughly before reassembling. Remove all grease and oil from surface.
- Read and understand all instructions and safeguards prior to using the food dehydrator.

Operating Instructions

WARNING

- After turning off the power on the circuit board, the fan will continue to run for at least two minutes in order to let the heater cool down. After the fan has stopped running, it is safe to unplug the power.

1. Make sure power switch is turned off. Place the unit on a clean, dry surface away from children and pets. Plug into an undamaged grounded electrical outlet.
2. Remove the racks from the dehydrator so that you can easily load them with your items to be dried.
3. Follow your recipe for the food that you wish to dehydrate then place the food evenly on the shelves provided. You can use cooking spray to help prevent sticking. Do not allow food pieces to touch. Allow ample space between pieces for air circulation.
4. Remove any excess water from food by blotting with a paper towel. Excess moisture may cause the temperature to drop.
5. Place shelves into the dehydrator.
6. Slide door into place.
7. After connecting to a power outlet, make sure that the power is adequately grounded. The standard power supply is 120V, 60HZ.
8. Press the "POWER" button, the timing value and initial temperature will display on the LCD screen. The initial temperature is in Fahrenheit.
9. To begin the initial set up, press the "SET" button once to adjust the hour. The clock function will be flashing. Press the "+" to adjust the time upwards and "-" to adjust the time down. The range is from 0 to 99.
10. Press the "SET" button twice to adjust the minute. The clock function will be flashing. Press the "+" to adjust the time upwards and "-" to adjust the time down. The minute will increase in 5 minute increments. The range is from 0 to 55.
11. To adjust the temperature, press the "SET" button three times. The temperature value will be flashing. The temperature will increase in 5 degree increments. The maximum temperature is 162 degrees Fahrenheit.
12. To change from Fahrenheit to Celsius, press and hold the "SET" button for at least 5 seconds until flashing. Press "-" to switch to Celsius. The previous adjustment will remain the same as the above.
13. Adjust the temperature knob to the desired temperature.
14. Push "Start" and the unit will begin to heat and the fan will turn on.
15. Water droplets may form on the surface of some products while dehydrating. These can be removed by blotting the product with a clean towel or paper towel. Use caution, the dehydrator becomes hot.

READ & SAVE THESE INSTRUCTIONS

16. The timing shown on the LCD board will countdown and the machine will shut off automatically when time has elapsed.
17. If it is necessary to stop the unit before time has elapsed simply push the “start/stop” button and the dehydrator will shut off. If drying appears to be uneven you may want to rotate shelves 180°. Use oven mitts, shelves will be hot.
18. If you would like to resume the dehydrating process simply push the “start/stop” button again and the dehydrator will resume heating and time countdown.
19. When dehydrating is complete, use oven mitts to remove the door and set it on a heat resistant surface. Slide shelves out and remove finished product.
20. Allow dehydrator to cool completely prior to clean up.
21. Set power switch to “off” position and disconnect the electrical cord from the outlet.
22. Wipe dehydrator with a clean damp cloth. Do not immerse the dehydrator in water.
23. Wash dehydrator trays with warm soapy water. Rinse and hand dry.

Food Drying Guides

⚠ WARNING

If jerky will not be refrigerated after dehydration it is highly recommended to cook the meat to 160° F prior to dehydrating to ensure product safety. This step assures that any bacteria present will be destroyed by wet heat. If jerky will be refrigerated it is not necessary to precook the meat.

For more information please visit USDA web page:

http://www.fsis.usda.gov/Fact_Sheets/Jerky_and_Food_Safety/index.asp. After turning off the power on the circuit board, the fan will continue to run for at least two minutes in order to let the heater cool down. After the fan has stopped running, it is safe to unplug the power.

The following charts are guidelines for the preparation of various fruits, vegetables and meats. Drying times will vary depending on the room temperature, relative humidity and moisture levels in the food that you are drying. If the moisture level is high, the drying time will be on the high end of the range. Keep in mind that drying times are also affected by the amount of food placed on the shelves. Overloading the shelves will slow the drying time and may produce poor results. When dehydrating foods, it is important to check on the dryness of the product. If the product is not thoroughly dried, mold may form during storage. To test for dryness, remove a piece of food from the dehydrator and allow cooling to room temperature. Bend and tear the piece to check for internal moisture.

Fruits at 135°F

Food	Preparation	Test	Time
Apples	Wash, core and peel if desired. Cut into 1/4" slices. Dust with cinnamon if desired.	Pliable	7-15 hours
Apricots	Wash, halve and remove pit. Slice if desired and dry skin side down.	Pliable	21-29 hours
Bananas	Wash, peel and slice into 1/8" slices.	Pliable	7-10 hours
Figs	Wash, cut out blemishes, quarter. Dry skin side down.	Pliable	22-30 hours
Kiwi	Wash, peel and slice into 1/4" slices.	Crisp	8-15 hours
Nectarines	Wash, halve and remove pit. Slice if desired and dry skin side down.	Pliable	8-17 hours

Peaches	Wash, halve and remove pit. Slice if desired and dry skin side down.	Pliable	8-16 hours
Pears	Wash, core and peel if desired. Cut into 1/4" slices or quarter.	Pliable	8-16 hours
Pineapple	Peel, remove fibrous eyes, remove core. Cut into 1/4" slices or wedges.	Pliable	11-18 hours
Rhubarb	Wash, cut into 1" lengths.	Pliable	6-10 hours
Strawberries	Wash, cut out caps, slice 1/4" thick	Crisp	7-15 hours
Watermelon	Cut off rind, cut into wedges and remove seeds.	Pliable and Sticky	8-10 hours

Jerky at 145-150°F

Food	Preparation	Test	Time
Jerky	Use lean meat and remove as much fat as possible. Fat turns rancid with time. Cut uniform 1/4" thick or less slices. Do not overlap slices on the shelves.	Pliable	3-4 hours Meat temperature should reach 145-150° F

Vegetables at 125°F

Food	Preparation	Test	Time
Asparagus	Wash and cut into 1" pieces	Crunchy	4-6 hours
Beans, Green or Waxed	Wash remove ends and cut into 1" pieces or French style	Crunchy	9-12 hours
Beets	Remove 1/2" of the top, scrub thoroughly, steam blanch until tender. Peel and cut into 1/4" thick slices.	Pliable	9-12 hours
Broccoli	Wash and trim. Cut stems into 1/4" pieces. Dry florets whole.	Crunchy	10-14 hours
Cabbage	Wash and trim. Cut stems into 1/8" strips.	Crunchy	8-11 hours
Carrots	Wash and trim tops. Peel or scrape if desired. Cut into 1/8" thick slices.	Pliable	7-11 hours
Celery	Wash, separate leaves and stalks. Cut stalks into 1/4" strips.	Crunchy	3-10 hours
Corn	Shuck corn and trim silk. Steam until milk is set. Cut kernels from cob and spread on plastic screen. Stir several times during drying.	Crunchy	7-10 hours
Cucumber	Wash and trim. Cut into 1/8" slices.	Pliable	4-8 hours
Eggplant	Wash and peel. Cut into 1/4" slices.	Pliable	4-8 hours
Mushroom	Wash and cut into 3/8" slices	Pliable	4-7 hours
Parsnips	Scrub thoroughly, steam blanch until tender. Peel if desired and cut into 3/8" thick slices.	Pliable/Tough	7-11 hours

Peppers	Wash and remove stems, seeds and white section. Pat dry. Cut into 1/4" thick strips or rings.	Pliable	4-8 hours
Potatoes	Use new potatoes. Wash, peel if desired. Steam blanch 4-6 minutes. Cut French style, 1/4" slices, 1/8" thick circles or grate.	Crunchy/Pliable	7-13 hours
Summer Squash	Wash and peel. Cut into 1/4" slices.	Crunchy	10-14 hours
Tomatoes	Wash and remove stems. Slice into 1/4" circles in half, dry skin side down.	Crunchy	5-9 hours
Zucchini	Wash, peel if desired. Cut into 1/4" slices or chips.	Crunchy	7-11 hours

Tips to Obtain the Best Results

- Choose high quality foods. Do not use foods with bruises or blemishes. Bad fruits and vegetables may spoil the entire batch. Fruits and vegetables in peak season contain more nutrients and more flavor. Meats, fish and poultry should be lean and fresh.
- Wash food, use clean utensils and keep work area clean.
- Pre-treat foods to prevent discoloration.
- Always use lean meats. Remove as much fat as possible prior to dehydrating. Use a paper towel underneath meat when dehydrating to absorb fat.
- Do not overlap foods. Lay foods flat on the Dehydrating Trays.
- If uneven drying is noticed, rotate shelves 180°.
- Check dryness every 2 hours until crisp, pliable or leathery depending on the product.
- Cool food before testing for dryness.
- Proper storage is essential to maintain the quality of the food. Vacuum sealing is ideal for keeping dried foods.
- Lay foods flat on drying rack.

Pre-Treatment of Foods

As with most types of cooking, proper preparation is essential for successful results. Adhering to a few basic guidelines will greatly increase the quality of your dried foods and decrease the amount of time necessary to dry them. Pre-treated foods often taste better and have a better appearance than non-treated foods. There are several methods to pre-treat food to prevent oxidation, which will darken apples, pears, peaches and bananas while drying.

- Remove any pits, skin or cores.
- Shred, slice or dice the food uniformly. Slices should be between 1/4" (0.6 cm) and 3/4" (1.9 cm) thick. Meats should be cut no more than 3/16" (0.5 cm) thick.
- Steam or roast meat to 160°F (71°C) and poultry to 165°F (74°C) as measured with a food thermometer before dehydrating.
- The temperature of the dehydrator must be maintained at 130-140°F (55-60°C)

throughout the drying process.

- Drying fish into jerky requires a lot of attention. It must be cleaned and de-boned properly and rinsed thoroughly to ensure that all the blood is washed away. Steam or bake the fish at 200°F (93°C) until flaky before dehydrating.
- Soak cut fruit in either lemon or pineapple juice for a few minutes before placing out on the dehydrating racks.
- Use an ascorbic acid mix which can be purchased in most health food stores or pharmacies. It may come in either powder or tablet form. Dissolve approximately 2-3 tablespoons into 1 quart of water. Soak the fruit slices into the solution for 2-3 minutes, then place on the dehydrating racks.
- Fruits with a wax coating (figs, peaches, grapes, blueberries, prunes, etc.) should be dipped in boiling water to remove the wax. This allows moisture to escape easily when dehydrating.
- Blanching can pre-treat food for dehydrating. Blanching does not destroy helpful enzymes and helps retain nutrients. There are two ways to blanch food:
- WATER BLANCHING: Use a large pan; fill it half way with water. Bring water to a boil. Place food directly into boiling water and cover. Remove after three minutes. Arrange food on the dehydrating racks.
- STEAM BLANCHING: Using steamer pot bring 2-3" (5-7 cm) of water to a boil in bottom section. Place food in steamer basket and steam for 3-5 minutes. Remove steamed food and arrange on dehydrating racks.

Making and Storing Jerky

WARNING

- If jerky will not be refrigerated after drying it is highly recommended to cook the meat to 160° F prior to dehydrating to ensure product safety. This step assures that any bacteria present will be destroyed by wet heat.
- After heating to 160° F maintaining a constant dehydrator temperature of 130-140° F during the drying process is important because the process must be fast enough to dry food before it spoils; and it must remove enough water so the microorganisms are unable to grow.
- If jerky will be refrigerated it is not necessary to precook the meat.
- If you are using a marinade, shake off excess liquid before placing the meat in evenly spaced single layers approximately ¼" apart on the racks.
- Dry meat at 145-150° F for 4-7 hours. You may need to blot fat droplets from the surface of the meat occasionally, using a paper towel. Drying times may vary based on many circumstances including but not limited to: the relative humidity of the room, the temperature of the meat at the beginning of the drying process, the amount of meat in the dehydrator, leanness of meat, etc.

1. Meat being used for jerky should be as lean as possible. Using lean meat will help the meat dry faster and aid in cleanup by decreasing fat drippings.
2. Using lean meat will help the meat dry faster. Ground meat should be 79%-90% lean. Ground turkey, venison, buffalo and elk are other excellent choices for jerky.
3. Jerky seasonings are available for all tastes or you can get creative and make your own.
4. Whenever jerky is being made, cure (sodium nitrite) should be used. Cure is used to help prevent botulism during drying at low temperatures. Follow the manufactures directions on the cure packet.

5. Keep raw meats and their juices away from other foods
6. Marinate meats in the refrigerator. Do not leave meats unrefrigerated. Always wash hands thoroughly with soap and water prior to and after working with meat products. Prevent cross-contamination by storing dried jerky away from raw meat.
7. Use clean equipment and utensils
8. Special consideration must be made when using venison or other wild game, as it can become heavily contaminated during field dressing. Venison is often held at temperatures that could potentially allow bacteria to grow, such as when it is being transported. Refer to the USDA Meat and Poultry Department for further information on meat and food safety.
9. When using a dehydrator, check the temperature of the dehydrator with a dial thermometer before drying jerky. The minimum recommended temperature for drying meats is 145° F.
10. Wrap jerky/snack sticks in aluminum foil and store in a thick plastic food storage bag, or place jerky/snack sticks in a jar with a tight lid.
11. Avoid storage in plastic containers or bags without first wrapping in aluminum foil or wax paper.
12. Jerky/snack sticks should be stored in a dark, dry place between 50-60°F (10-16°C). You can store properly dried jerky/snack sticks at room temperature for 1 to 2 months.
13. To extend the shelf life to up to 6 months, store jerky/snack sticks in the freezer. Be sure to label and date all packages.

Fruit Roll-Ups

- Select ripe or slightly over-ripe fruits. Wash and remove blemishes, pits and skin.
- Puree in a blender. Add yogurt, sweeteners or spices as desired. The puree should be thick in consistency.
- Cover the dehydrator racks with plastic wrap.
- Pour 1-1/2 to 2 cups of the puree onto the covered racks. Carefully place the racks in the dehydrator.
- The edges will dry quicker than the center, pour the puree thinner at the center of the tray.
- The average drying time for the fruit roll-ups is 4 to 6 hours.
- Once the fruit roll-ups are shiny and non-sticky to the touch, remove them from the dehydrator and allow them to cool.
- Peel the fruit roll-up from the plastic wrap and roll into cylinders.

Drying Flowers and Crafts

- The flowers should be dry to start with, best if picked after the dew has dried and before the night dampness sets in. Dry the flowers as soon as possible after picking.
- The best condition for drying flowers is a dry, warm, dark, clean and well ventilated area, which makes a dehydrator an ideal setting. Flowers will retain the best color and condition when dried quickly.
- A low temperature should be used to retain the natural oils.
- Strip off leaves or keep the foliage. Discard any brown or damaged leaves.

- Place on the dehydrator tray in a single layer, avoiding overlapping.
- Drying times will vary considerably depending on the size of the flower and the amount of foliage. Dry at 100°F (38°C).
- Dough art and beads can be dried in the dehydrator. Temperatures may vary.

Reconstituting Dried Foods

- While it is not necessary to reconstitute your dried foods, you can do so with ease. Vegetables can be used as a side dish or in recipes very effectively after being reconstituted in the following way.
- Dehydrated food can be re-hydrated by soaking in cold water for 3-5 minutes. Use 1 cup of water for 1 cup of dehydrated food. Once re-hydrated, the food can be cooked normally.
- Soaking foods in warm water will speed up the process, however, it may result in loss of flavor.
- Dehydrated fruits and vegetables can be soaked in cold water for 2-6 hours in the refrigerator. **WARNING!** Soaking at room temperature allows harmful bacteria to grow.
- Do not add seasoning. Adding salt or sugar during rehydration may change the flavor of the food.
- To make stewed fruits or vegetables, add 2 cups of water and simmer until tender.
- Consume dehydrated foods as soon as possible once the storage container is opened. Keep any unused portions in the refrigerator to avoid contamination.

Recipes

HAWAIIAN JERKY MARINADE

1 tsp Salt	1 tsp ground Ginger	1/4 cup Pineapple Juice
1 Tbsp Brown Sugar	1/4 tsp Pepper	1/8 tsp Cayenne Pepper
1 crushed Garlic Clove	1/4 cup Soy Sauce	1 lb. lean Meat, sliced into 1/8-1/4" thin strips

CAJUN JERKY MARINADE

1 cup Tomato Juice	1/2 tsp Garlic Powder	1/2 tsp ground Black Pepper
1-1/2 tsp dried Thyme	1-1/2 tsp dried Basil	1-1/2 tsp Onion Pepper
2 tsp Cayenne Pepper (or more to taste)	1 tsp White Pepper	1 lb. lean Meat, sliced into 1/8-1/4" thin strips

HOT JERKY MARINADE

1/3 cup Teriyaki Sauce	1 tsp ground Horseradish	2 tsp Brown Sugar
2 tsp ground Black Pepper	1 tsp Salt	1/2 tsp Paprika
1/2 tsp Chili Powder	1 Tbsp. Olive Oil	1 Tbsp. minced Garlic
2 Tbsp. seeded & finely chopped Jalapeno Peppers	1/4 tsp Tabasco Sauce	1 lb. lean Meat, sliced into 1/8-1/4" thin strips

BURGUNDY JERKY MARINADE

2 cups Burgundy Wine	1/2 cup Soy Sauce	3 Cloves Garlic, chopped
1 Tbsp. ground Black Pepper	3 Tbsp. Molasses Syrup	1 lb. lean Meat, sliced into 1/8-1/4" thin strips

TURKEY JERKY MARINADE

1/4 cup Soy Sauce	1 Tbsp. fresh Lemon Juice	1/4 tsp powdered Garlic
1/4 tsp ground Black Pepper	1/8 tsp Ginger	1 1/2 lbs. Turkey Breast, sliced into 1/8-1/4" thin strips

VENISON JERKY MARINADE

1/3 cup Soy Sauce	1 Tbsp. Brown Sugar	1 tsp Salt
1/2 tsp ground Black Pepper	1/2 tsp Minced Garlic	1 lb. Venison, sliced into 1/8-1/4" thin strips

INSTRUCTIONS

In a small glass bowl, combine all ingredients except the meat/poultry. Mix thoroughly. Place a layer of meat/poultry into a glass baking dish, spoon sauce mixture over each layer. Repeat until meat/poultry is 3-4 layers deep in the pan. Cover tightly and marinate for 6-12 hours in the refrigerator or overnight. Stir occasionally to keep the meat/poultry coated in marinade. The longer the meat/poultry stays in the marinade, the more flavor will be absorbed into it. Remove the meat/poultry from the marinade, removing excess marinade. Lay the meat/poultry evenly onto the dehydrator Racks, leaving 1/4" (0.6 cm) space between each strip of meat/poultry. Dry meat/poultry at 145-150°F (63-66°C) for 4-7 hours or until thoroughly dry.

NOTE: When using a dehydrator, check the temperature of the dehydrator with a dial thermometer before drying jerky. The minimum recommended temperature for drying meats is 145°F (63°C). Temperatures below 145°F (63°C) are not recommended. IMPORTANT: Before you place the meat in a dehydrator, it is highly recommended to heat the meat to 160°F (71°C) BEFORE the dehydrating process. This step assures that any bacteria present will be destroyed by wet heat. After heating to 160°F (71°C), maintain a constant dehydrator temperature of 130-140°F (55-60°C) during the drying process. You may need to blot fat droplets from the surface of the meat occasionally using a paper towel. Drying times may vary based on many circumstances including but not limited to: the relative humidity of the room, the temperature of the meat at beginning of drying process, the amount of meat in the dehydrator, leanness of meat, etc. Always allow jerky to cool before taste testing.

YOGURT

1 quart Milk	1/2 cup Powdered Milk	2 Tbsp. Plain Commercial Yogurt (or 2-3 Tbsp. of Yogurt Starter)
Fruits	Sweeteners	

INSTRUCTIONS

In a saucepan mix milk, powdered milk together, heat to scalding. Remove from heat and let cool to 110°F (43°C). Mix the yogurt well with the cooled scaled milk (if using yogurt starter, add to 1/3 cup scaled milk and mix well, then return to the remaining milk). Set the dehydrator to 108°F (42°C). NOTE: If the temperature is too high the yogurt will curdle. If the temperature is too low, the yogurt will take longer to thicken. Pour the milk yogurt mixture into flat containers and cover with plastic wrap. Place the flat containers in the dehydrator for 2-4 hours or until thickened. Remove the yogurt from the dehydrator and allow to cool. Stir in the flavorings or fruits to taste.

Food Safety

- It's crucial to cook food to a safe internal temperature to destroy bacteria that is present. The safety of hamburgers and other foods made with ground meat has been receiving a lot of attention lately, and with good reason. When meat is ground, the bacteria present on the surface is mixed throughout the ground mixture. If this ground meat is not cooked to at least 160°F to 165°F (71°C to 74°C), bacteria will not be destroyed and there's a good chance you will get sick.
- Solid pieces of meat like steaks and chops don't have dangerous bacteria like E. coli on

the inside, so they can be served more rare. Still, any beef cut should be cooked to an internal temperature of at least 145°F (63°C) (medium rare). The safe temperature for poultry is 180°F (82°C) and solid cuts of pork should be cooked to 160°F (71°C). Eggs should be thoroughly cooked too. If you are making a meringue or other recipe that uses uncooked eggs, buy specially pasteurized eggs or use prepared meringue powder.

- Foods that will be eaten uncooked and foods that will be cooked before eating MUST ALWAYS be separated. Cross-contamination occurs when raw meats or eggs come in contact with foods that will be eaten uncooked. This is a major source of food poisoning. Always double-wrap raw meats and place them on the lowest shelf in the refrigerator so there is no way juices can drip onto fresh produce. Then use the raw meats within 1-2 days of purchase, or freeze for longer storage. Defrost frozen meats in the refrigerator, not on the counter.
- When grilling or cooking raw meats or fish, make sure to place the cooked meat on a clean platter. Don't use the same platter you used to carry the food out to the grill. Wash the utensils used in grilling after the food is turned for the last time on the grill, as well as spatulas and spoons used for stir-frying or turning meat as it cooks.
- Make sure to wash your hands after handling raw meats or raw eggs. Washing hands with soap and water is absolutely necessary after you have touched raw meat or raw eggs. Not washing hands and surfaces while cooking is a major cause of cross-contamination.
- Wash your hands and work surfaces frequently when you are cooking. Washing with soap and warm water for at least 15 seconds, then dry with a paper towel.
- Chilling food is very important. The danger zone where bacteria multiply is between 40°F and 140°F (4°C and 6°C). Your refrigerator should be set to 40°F (4°C) or below; your freezer should be 0°F (-17°C) or below. Simple rule: serve hot foods hot, cold foods cold. Use chafing dishes or hot plates to keep food hot while serving. Use ice water baths to keep cold foods cold. Never let any food sit at room temperature for more than 2 hours - 1 hour if the ambient temperature is 90°F (32°C) or above. When packing for a picnic, make sure the foods are already chilled when they go into the insulated hamper. The hamper won't chill food - it just keeps food cold when properly packed with ice. Hot cooked foods should be placed in shallow containers and immediately refrigerated so they cool rapidly. Make sure to cover foods after they are cool.
- **NOTE:** Special considerations must be made when using venison or other wild game, since it can become heavily contaminated during field dressing. Venison is often held at temperatures that could potentially allow bacteria to grow, such as when it is being transported. Refer to the USDA Meat and Poultry Department for further questions or information on meat and food safety.

Problem Solving and Troubleshooting

Faults	Causes Analysis	Solutions
If within 30 minutes, the temperature of the dehydrator has not increased.	Check if the fan has a foreign object stuck in it.	Turn off power, unplug the power supply, remove foreign object, then plug back in and restart.
	After the machine is off, the waste heat of heater causes the fuse to disconnect.	Unplug the power supply, let the unit cool down for 20 minutes, then restart.

Moisture in the storage container	Incomplete drying, food cut unevenly, thus incomplete drying. Dried foods left at room temperature too long after cooling, moisture has re-entered the foods.	Test food for dryness before removing from the dehydrator. Cut foods evenly. Cool quickly and package immediately.
Mold on Food	Incomplete drying. Food not checked for moisture content within a week. Storage container not air-tight or too warm or moisture in food. Case hardening may have occurred, meaning the food was dried at too high of heat which results in food dried on outside but not completely dried on the inside.	Test several food pieces for dryness. Check the storage container within one week for moisture, then re-dry food if needed. Use air-tight containers for storage. Store foods in cool areas that are 70 degrees Fahrenheit or below. Dry foods at appropriate temperatures and use the drying guide for reference.
Brown Spots on Vegetables	Too high of drying temperature used. Vegetables were over-dried.	Dry foods at appropriate temperatures, use the drying guide for reference. Check foods often for dryness.
Food Sticking to Racks	Food not being turned over.	After one hour of dehydrating, use a spatula and flip the foods.

Cleaning and Maintenance

1. Make sure the power is off and the dehydrator is cool before cleaning the dehydrator. Use a damp sponge or washcloth to clean the outside surfaces and the inside of the cabinet. Do not splash water onto the heating element. Water may damage the electrical components and increases the risk of electrical shock. Do not immerse dehydrator in water.
2. Clean dehydrator racks with warm and soapy water. Rinse with clear water and dry immediately.
3. Check whether the fan is running normally.

Replacement Parts

- For replacement parts and technical questions, please call Customer Service at **1-800-545-9633** or email at customerservice@forcome.com.
- Not all product components are available for replacement. The illustrations provided are a convenient reference to the location and position of parts in the assembly sequence.
- When ordering parts, the following information will be required: item description, item model number, item serial number/item lot date code, and the replacement part reference number.
- The distributor reserves the rights to make design changes and improvements to product lines and manuals without notice.

Limited Warranty

The Sportsman's Guide and Northern Tool and Equipment Company, Inc. ("We" or "Us") warrants to the original purchaser only ("You" or "Your") that the Guide Gear product purchased will be free from material defects in both materials and workmanship, normal wear and tear excepted, for a period of **one year** from date of purchase. The foregoing warranty is valid only if the installation and use of the product is strictly in accordance with product instructions. There are no other warranties, express or implied, including the warranty of merchantability or fitness for a particular purpose. If the product does not comply with this limited warranty, Your sole and exclusive remedy is that We will, at our sole option and within a commercially reasonable time, either replace the product or product component without charge to You or refund the purchase price (less shipping). This limited warranty is not transferable.

Limitations on the Warranty

This limited warranty does not cover: (a) normal wear and tear; (b) damage through abuse, neglect, misuse, or as a result of any accident or in any other manner; (c) damage from misapplication, overloading, or improper installation; (d) improper maintenance and repair; and (e) product alteration in any manner by anyone other than Us, with the sole exception of alterations made pursuant to product instructions and in a workmanlike manner.

Obligations of Purchaser

You must retain Your product purchase receipt to verify date of purchase and that You are the original purchaser. To make a warranty claim, contact Us at 1-800-545-9633, identify the product by make and model number, and follow the claim instructions that will be provided. The product and the purchase receipt must be provided to Us in order to process Your warranty claim. Any returned product that is replaced or refunded by Us becomes our property. You will be responsible for return shipping costs or costs related to Your return visit to a retail store.

Remedy Limits

Product replacement or a refund of the purchase price is Your sole remedy under this limited warranty or any other warranty related to the product. We shall not be liable for: service or labor charges or damage to Your property incurred in removing or replacing the product; any damages, including, without limitation, damages to tangible personal property or personal injury, related to Your improper use, installation, or maintenance of the product or product component; or any indirect, incidental or consequential damages of any kind for any reason.

Assumption of Risk

You acknowledge and agree that any use of the product for any purpose other than the specified use(s) stated in the product instructions is at Your own risk.

Governing Law

This limited warranty gives You specific legal rights, and You also may have other rights which vary from state to state. Some states do not allow limitations or exclusions on implied warranties or incidental or consequential damages, so the above limitations may not apply to You. This limited warranty is governed by the laws of the State of Minnesota, without regard to rules pertaining to conflicts of law. The state courts located in Dakota County, Minnesota shall have exclusive jurisdiction for any disputes relating to this warranty.



Distributed by:

The Sportsman's Guide

And

Northern Tool & Equipment Company, Inc.

Burnsville, Minnesota 55306

www.sportsmansguide.com www.northerntool.com