

# LAW TACTICAL

GENERATION 3-M

# AR FOLDING STOCK ADAPTER:

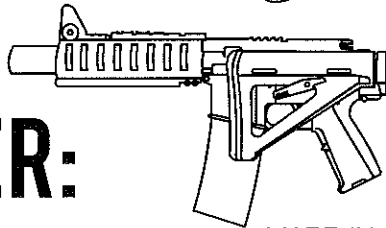

For use with AR variants utilizing a buffer and action spring, including all types of gas systems and rifle calibers from 5.56 to .308

**PATENT 8769855**  
**WWW.LAWTACTICAL.COM**

SEE WARNINGS  
BEFORE INSTALLATION

**\*\*\* WARNINGS \*\*\***

Observe Safe Firearm Handling At All Times

FIREARM MODIFICATIONS SHOULD BE PERFORMED BY A CERTIFIED ARMORER OR GUNSMITH

Before removing or installing any part, ensure the firearm is UNLOADED with the SAFETY ENGAGED. Remove the source of ammunition. Check chamber and magazine well to ensure weapon is unloaded, and then CHECK AGAIN!

Always close stock (unfold) before firing. The AR is not designed to be fired from the folded position.

To avoid accidental firing in the folded position, the SAFETY should ALWAYS be ENGAGED BEFORE FOLDING stock and should REMAIN ENGAGED until stock is unfolded.

## 1. PREPARE FOR INSTALLATION

\*\*\* Parts (1) and (1a) are preassembled with the Hinge Bolt (10) and should not be disassembled \*\*\*

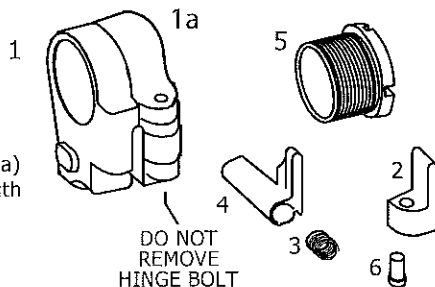

DO NOT REMOVE HINGE BOLT

Using a 9/64 Allen Wrench, remove the Hex Screw (6) from the Side Plate Cover (2). Next, remove the Side Plate Cover (2) from the receiver side of the Hinge Assembly (1). With the plate cover removed, separate the Button Spring (3) and Button (4) from the Hinge Assembly (1).

## PARTS LIST:

- 1 Hinge Assembly (Receiver Side)
- 1a Hinge Assembly (Stock Side)
- 2 Side Plate Cover
- 3 Button Spring
- 4 Button
- 5 Threaded Flange
- 6 Hex Screw 9/64
- 7 Flange Set Screw 3/32
- 8 Flange Tool
- 9 Bolt Carrier Extension
- 10 Hinge Bolt
- 11 Buffer Retaining Set Screw 5/16 (do not adjust or remove)

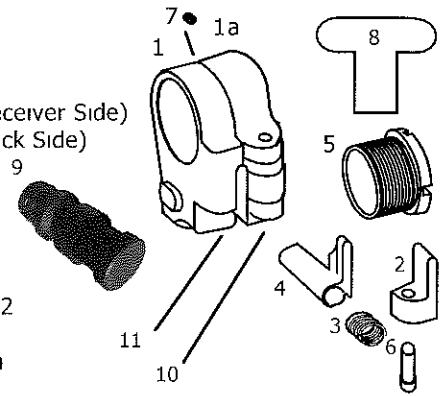

## MAINTENANCE:

**Hinge Tension:** A 1/8 Allen Wrench can be used to increase hinge tension by tightening the Hinge Screw (10). Do not remove during installation or general maintenance.

**O-rings:** Regularly check the Bolt Carrier Extension O-rings for wear or damage. If any wear or damage is visible, the O-rings should be replaced. If the adapter is accidentally or intentionally fired while folded, the O-rings should be replaced to prevent further damage to the adapter.

**Lubrication:** Regularly lubricating the locking latch and lug is recommended. Cleaning and lubrication of the exterior housing is also recommended.

## 2. REMOVE STOCK ASSEMBLY

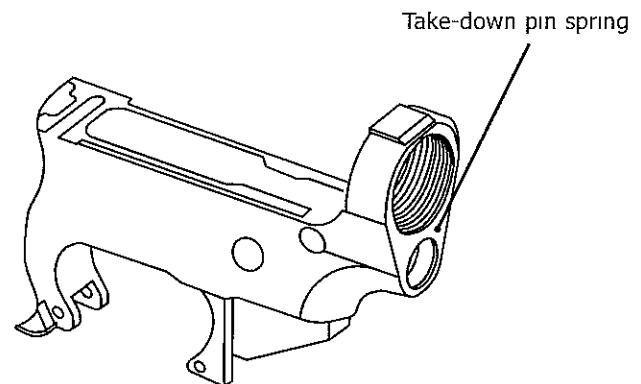

Ensure the weapon is unloaded with the safety engaged! Remove the stock from the rifle, remove the buffer and action spring from the buffer tube, and then remove the buffer tube (receiver extension) from the receiver. When removing the stock and tube from the receiver, use care not to lose the take-down pin spring and detent. For detailed information on removing the stock assembly from the receiver, refer to the firearms manual or the US Army Maintenance Manual TM 9-1005-319-23&P.

### 3. INSTALL FOLDING STOCK ADAPTER

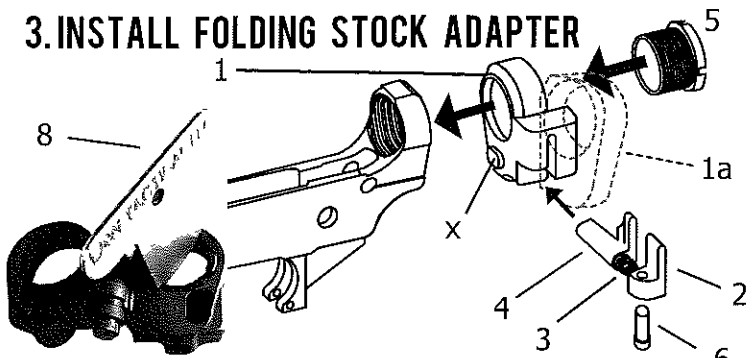

With the Button Spring (3), Button (4) and Threaded Flange (5) still separated from the Hinge Assembly (1), place the Hinge Assembly onto the rear of the receiver of the firearm. Place it over the take-down pin spring, and aligning the protrusion of the Hinge Assembly (X) with the index indentation on the receiver as you would with an A2 style stock. While holding the Hinge Assembly in place, screw the Threaded Flange (5) into the receiver of the firearm as you would a buffer tube. The four cut-outs on the flange are designed so that the included Flange Tool (8) can be used to tighten the Threaded Flange (5) into the receiver, until it firmly holds the Hinge Assembly onto the receiver. When the Flange Tool (8) starts to flex, proper torque has been applied. Next, reinstall the Button (4), and then the Button Spring (3) into the Hinge Assembly. Cover the Button Spring (3) with the Side Plate Cover (2), and using an 9/64 Allen Wrench, reinstall the Hex Screw (6).

### 4. INSTALLING THE STOCK

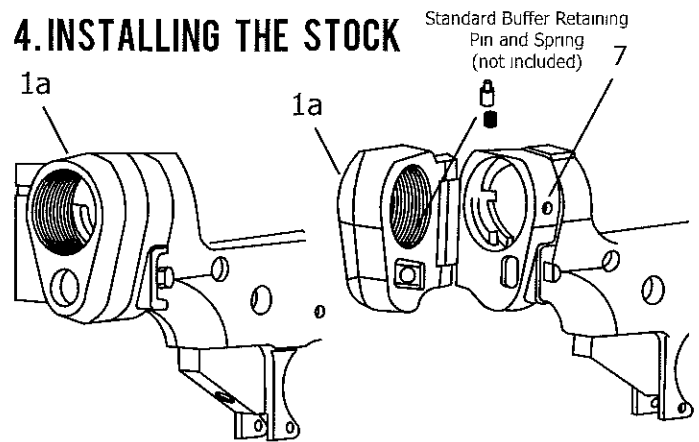

With the folding stock adapter tightly installed on the receiver, using a 3/32 Allen Wrench, tighten Flange Set Screw (7) to secure the Threaded Flange. Make snug but do not over tighten.

The buffer tube (receiver extension) assembly can now be installed onto the Stock Side of the Hinge Assembly (1a). Be sure to install your Buffer Retaining Pin and Buffer Retaining Spring into the stock side of the Hinge Assembly in the manner they would normally be installed in the receiver. Then install the Buffer Tube and stock onto the Hinge Assembly (1a) in the same manner it would be installed onto the rear of the rifle receiver. For additional information on installing stocks, see the rifle's manual or a US Army Maintenance Manual.

### 5. INSTALL BUFFER AND ACTION SPRING

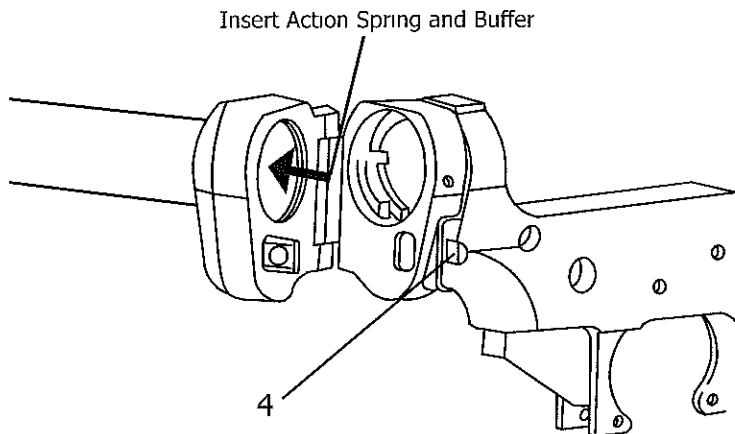

Once the buffer tube and stock are installed, push the Button (4) of the folding stock adapter and fold open the stock. With the stock folded and the inside of the buffer tube visible, install the buffer and action spring into the buffer tube, as would normally be done, by pushing them into the buffer tube, overriding the Buffer retaining pin. When folded over, the buffer and action spring are held in place by the buffer retaining pin, in the same manner they would be held when the upper and lower receiver are separated in a normal rifle configuration.

### 6. INSTALL BOLT CARRIER EXTENSION

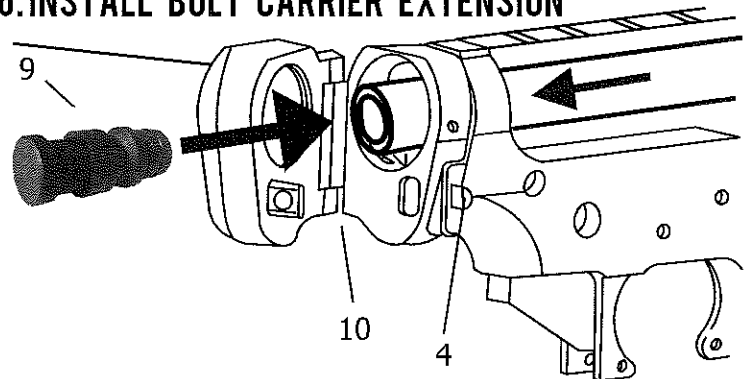

With the stock folded, depress and hold the button (4). Pull the charging handle, moving the bolt carrier group to the rear, so that the bolt carrier group is protruding from the back of the receiver. The Bolt Carrier Extension (9) can now be inserted into the rear of the bolt carrier group. Turning the bolt carrier extension while inserting will ease installation. Be sure the Bolt Carrier Extension is fully inserted, up to the first shoulder. With the extension installed, depress the button (4) and push the combined Bolt Carrier Extension (9) / Bolt Carrier group back into the receiver and into battery. Release the button (4) so that the Bolt Carrier Extension / Bolt carrier group is held in position. To remove the Extension, reverse the process above. Using a 1/8 Allen Wrench, tighten the Hinge Screw (10). This will increase hinge tension and insure maximum rigidity in the fire position. Installation is now complete.

**\*\*\* An alternate Bolt Carrier Extension will be available for bolt carriers with a smaller 1/2 diameter hole (e.g. PWS bolt carriers). \*\*\***