

SCORPION 3™

A FLY-FIRST PITCH TYPE DESIGN TENT

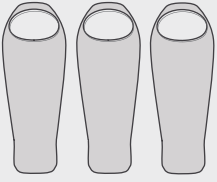

3 PERSON



WEIGHT

Trail Weight - 2.9kg/6.4lbs (Fly, Poles & Inner Tent)

Pack Weight - 3.4kg/7.5lbs (Fly, Poles, Inner Tent, Stakes, Guy Ropes & Compression Storage Bag)



MESH DOOR



INNER TENT



OUTER VENTS



OUTER DOOR



INTERNAL DOOR

FLYSHEET SIDE VIEW

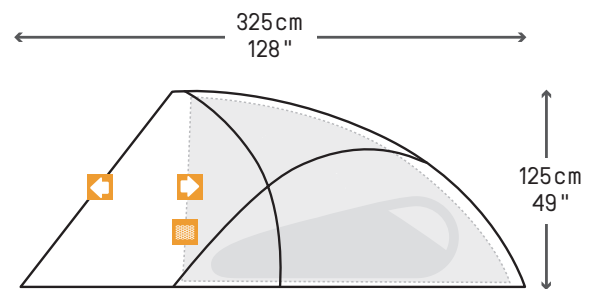

FLYSHEET TOP VIEW

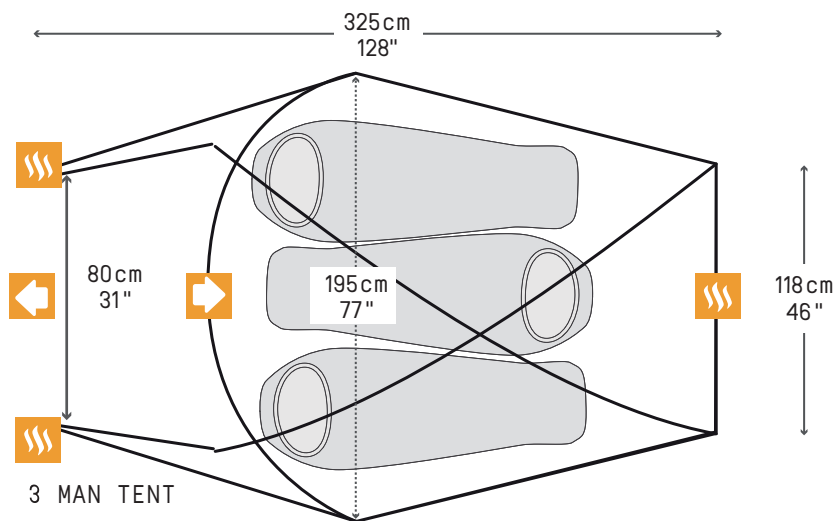

COMPRESSION STORAGE BAG



MESH INNER TOP VIEW & SIDE VIEW

